

## INSTALLATION INFORMATION

### **⚠ WARNING ⚠**

**Read these instructions carefully before attempting to install, operate or service this switch.**

**Failure to observe safety information and comply with instructions could result in personal injury, death and/or property damage.**

**To avoid electrical shock or damage to equipment, disconnect power before installing or servicing.**

**To avoid potential fire and/or explosion, do not use in potentially flammable or explosive atmosphere.**

**Retain these instructions for future reference. You must review your application and national and local codes to ensure that your installation will be functional and safe.**

### GENERAL INFORMATION

You are installing one of the finest gas pressure switches of its type on the market. Design of these switches is based on the same principles of sensitivity, accuracy and dependability that have made Antunes Controls Air Flow Switches so successful. These switches are fully approved. They are C-UL listed and recognized for the U.S. and Canada, approved by Factory Mutual (FM).

Antunes Controls Gas Pressure Switches monitor gas pressure. The models are available in high pressure and low pressure single gas switches. Pressure range varies from .5" of water column to 4 psi.

Each switch is adjustable within its range, as shown on the range scale located on top of the unit. The latch button in the reset models, and the optional neon light in the recycle models, show whether the switch is on or off.

The Model G is sturdy, compact and cost effective. All components are well made.

The switch is neat in appearance with its durable plastic electrical housing and die cast aluminum base. In every way you will be pleased with the ease of installation and the reliability of Antunes Controls Gas Pressure Switches.

Please read these instructions carefully to ensure correct installation. This equipment must be installed by a licensed electrician who is experienced with combustion safeguard control systems and understands the functions of interlocking switches such as air and gas pressure switches. Prior to being put into operation with combustion safeguard systems, all switches should be tested for proper range setting and wiring. Check piping connections and switch housing for leaks with a soap bubble test. All exhaust fans and blowers should be inspected and checked for proper rotation prior to start up. If you have any problems or questions, phone, fax or write to Antunes Controls at the numbers listed on the back page of this instruction sheet.

### ELECTRICAL

#### Ratings

10A @ 125 VAC  
 10A @ 250 VAC  
 1/3 HP, 125 & 250 VAC

#### Adjustable Operating Pressure

.5W.C. to 4 psi (different ranges)

#### Surge Pressure

15 psi (1 Bar)

#### Maximum Operating Pressure

6 psi (400 mbar)

#### Ambient Operating Pressure

-40°F to 140°F (-40°C to 60°C)

Field wiring to be rated @ 60°C for maximum 140°F ambient.

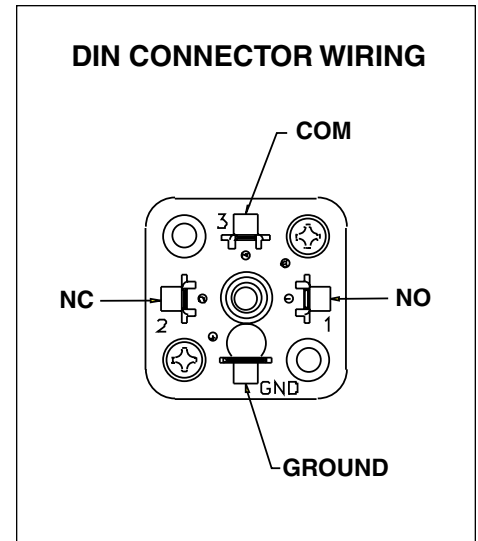
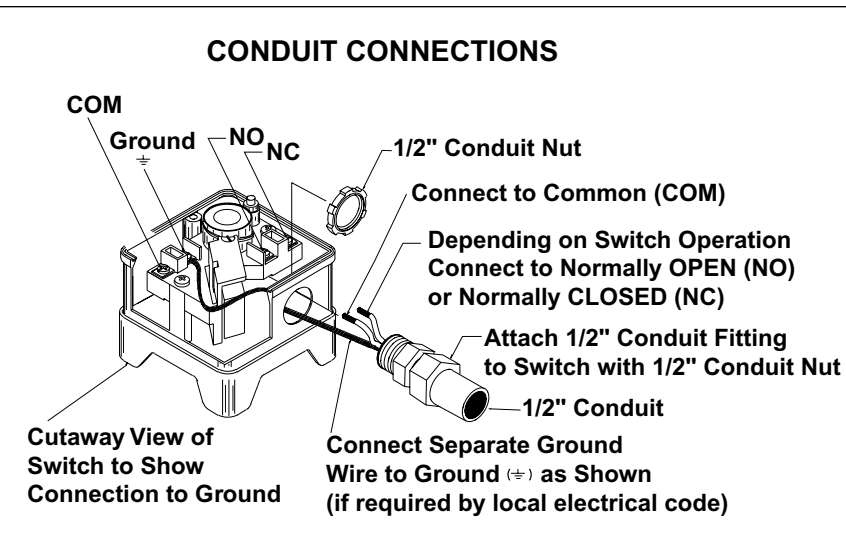
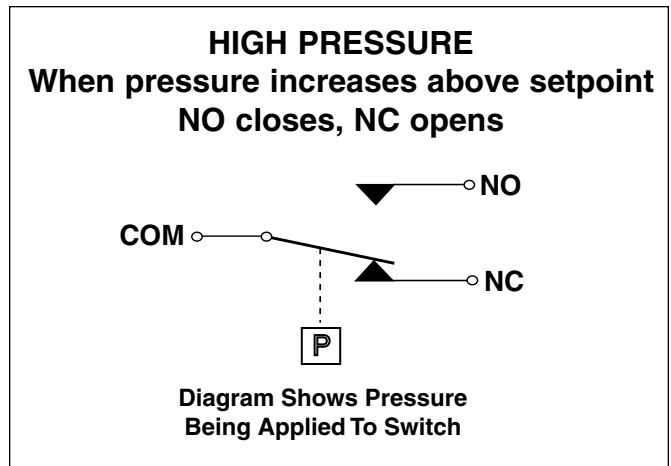
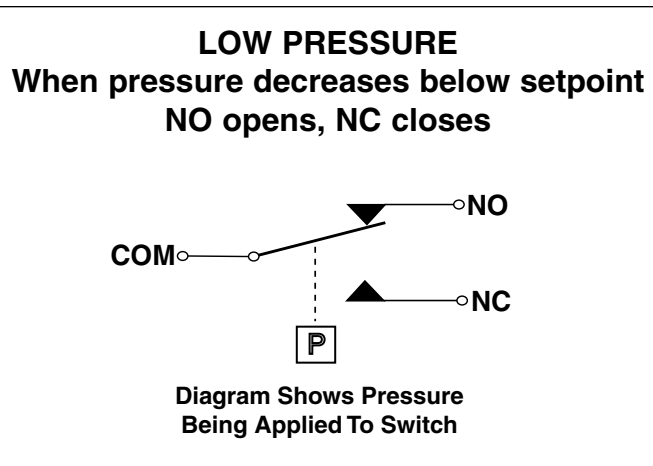
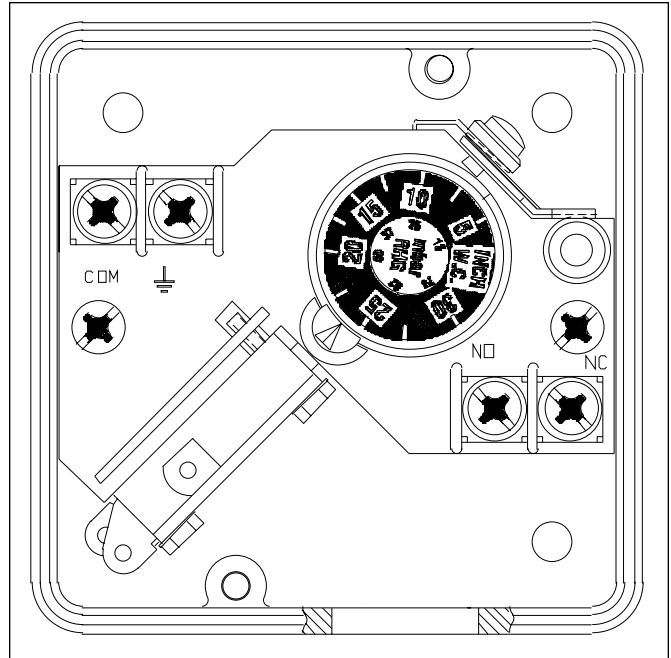

### MOUNTING

All switches can be mounted in either horizontal or vertical position. Switches should be reasonably level but do not required accurate levelling.

Single gas switch models have a 1/4" N.P.T. (female) gas inlet on the standard base.

Piping can be either standard black pipe or aluminum tubing.

All switches can be supported by the inlet pipe, but optional mounting brackets and bases are available (see Figures 1 thru 5 below).

Switches have been factory calibrated and tested for leaks. However, it is recommended that switch, gas pipe inlets and connections be soap bubble tested for leaks after installation.

### OPERATION

#### Low Gas Pressure Models

Low gas pressure switches break the electrical circuit on pressure drop at the point when gas pressure becomes lower than the indicated set pressure.

Before the manual reset button (figure 6) can be properly latched, gas pressure in the chamber must be higher than the indicated setting. The position of the yellow ring, on the reset button, shows whether the reset button is on or off. If the yellow ring on the button is below the cover, the unit is on (not latched). If the yellow ring is above the cover, the unit is off (latched). The yellow ring must be below the cover after latching to be properly set.

#### High Gas Pressure Models

High gas pressure switches break the electrical circuit when pressure rises above the indicated preset pressure. The yellow ring will be below the cover, indicating that the switch is on, when the gas pressure in the switch chamber is below the indicated high setting. When the yellow ring on the reset button is above the cover, it indicates the switch is in the off position, and gas pressure is above the indicated setting.

#### Range Adjustment - All Models

To adjust gas pressure cut-off setting, remove the cover. Turn the range scale adjustable knob (Figure 6) clockwise to increase pressure setting, counterclockwise to decrease pressure setting. Install cover and tighten the two cover screws to prevent tampering.

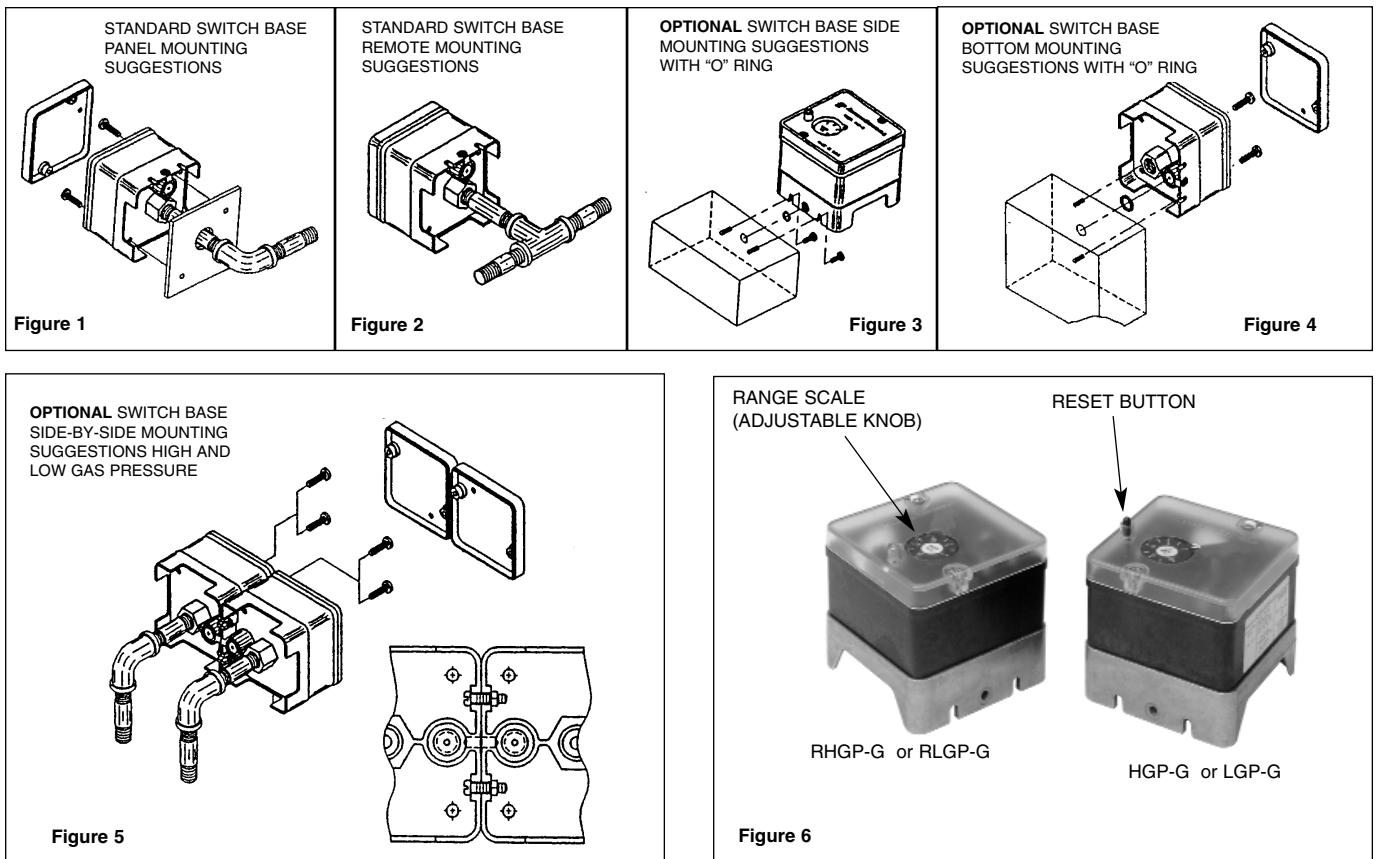

### SPECIFICATIONS

#### Models

##### RESET

LGP-G Single Unit, Lo-Pressure  
HGP-G Single Unit, Hi-Pressure

##### RECYCLE

RLGP-G Single Unit, Lo-Pressure  
RHGP-G Single Unit, Hi-Pressure

These part numbers are for standard 1/4" N.P.T. gas inlet and 1/2" electrical knockout.

**NOTE:** For optional NEMA 4 Kit, 4-Pin DIN Connector, Neon Lamp Indicator, or Side Mounting, contact **Antunes Controls** for specific part numbers.

#### OPTIONAL (CONTACT ANTUNES CONTROLS)

NEMA 4 (IP-65) Kit available, Part No. 808000404  
4-Pin DIN Connector  
Neon Lamp Indicator  
Side Mounting

#### LOW RANGES AVAILABLE

	Part No.	W.C.	mbar
LGP-G	8103116101	.5" - 4"	1-10
	8103116202	1" - 20"	3-50
	8103116303	5" - 30"	13-75
	8103116407	7" - 55"	17-136

	Part No.	W.C.	mbar
RLGP-G	8104116102	.5" - 4"	1-10
	8104116203	1" - 20"	3-50
	8104116304	5" - 30"	13-75
	8104118005	1-4	.07-.28

#### HIGH RANGES AVAILABLE

	Part No.	W.C.	mbar
HGP-G	8101111202	2" - 20"	5-50
	8101111303	8" - 35"	18-87
	8101111407	10" - 60"	25-150

	Part No.	W.C.	mbar
RHGP-G	8102111102	.8" - 4"	3-10
	8102111203	2" - 20"	5-50
	8102111304	5" - 35"	13-87
	8102113005	1-4	.07-.28

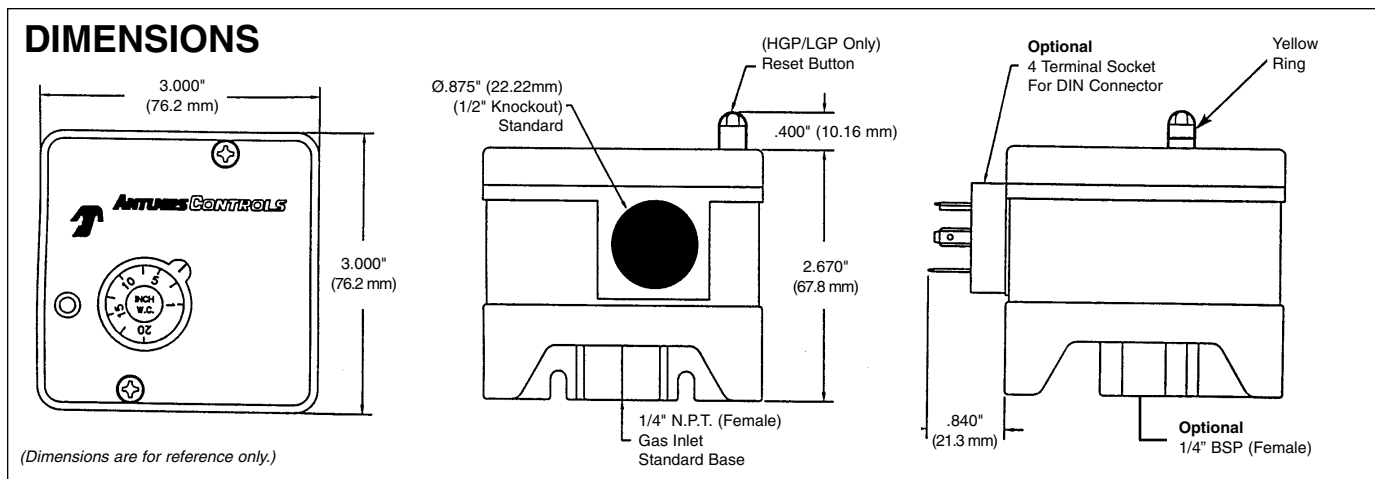

**Limitation of Liability.** If it is understood and agreed that seller's liability whether in contract, in tort, under any warranty, in negligence or otherwise, shall not exceed the return of the amount of the purchase price paid by purchaser and under no circumstances shall seller be liable for special, indirect or consequential damages. The price stated for the equipment is a consideration in limiting seller's liability. No action, regardless of form, arising out of the transactions may be brought by purchaser more than one year after the cause of action has accrued.