



Direct Acting or Piloted
Aluminum Body Solenoid Valves
 1/8" to 3" NPT

NC		NC		2/2 SERIES 8040 8215
NO		NO		

Features

- Lightweight, low-cost valves for air service.
- Ideal for low pressure applications.
- Provides high flow, Cv up to 138 (Kv 118).
- Air and vacuum service.

Construction

Valve Parts in Contact with Fluids	
Body	Aluminum
Seals, Diaphragms, Disc	NBR
Disc-Holder	PA (10.1 and 11.6 watt Normally Open only)
Core Guide	CA
Core Tube	305 Stainless Steel
Rider Rings	PTFE
Core and Plugnut	430F Stainless Steel
Springs	302 Stainless Steel
Shading Coil	Copper

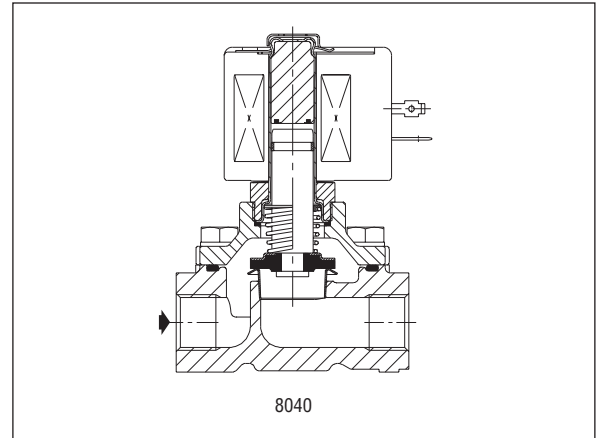
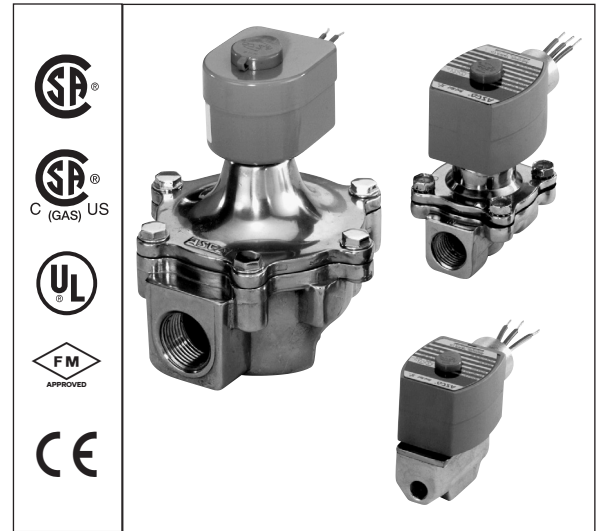

Electrical

Standard Coil and Class of Insulation	Watt Rating and Power Consumption				Spare Coil Part No.			
	DC Watts	AC			General Purpose		Explosionproof	
		Watts	VA Holding	VA Inrush	AC	DC	AC	DC
F	-	6.1	16	40	238210	-	238214	-
F	11.6	10.1	25	70	238610	238710	238614	238714
B	14.9	-	-	-	-	62691	-	-
F	-	15.4	27	160	99257	-	99257	-
F	-	28.2	50	385	206409	-	206409	-

Standard Voltages: 24, 120, 240, 480 volts AC, 60 Hz (or 110, 220 volts AC, 50 Hz), 6, 12, 24, 120, 240 volts DC. Must be specified when ordering. Other voltages available when required.

Solenoid Enclosures

Standard: Red-Hat II - Watertight, Types 1, 2, 3, 3S, 4, and 4X; Red-Hat - Type I.
Optional: Red-Hat II - Explosionproof and Watertight, Types 3, 3S, 4, 4X, 6, 6P, 7, and 9; Red-Hat - Explosionproof and Raintight, Types 3, 7, and 9. (Except EF8215A40 and EF8215A90, which are suitable for Types 3 and 7 (C and D) only and have a T2B temperature rating code.) To order, add prefix "EF" to catalog number. See *Optional Features Section* for other available options.

Nominal Ambient Temperature Ranges:

- Red-Hat II/ Red-Hat AC: 32°F to 125°F (0°C to 52°C)
- Red-Hat II DC: 32°F to 104°F (0°C to 40°C)
- Red-Hat DC: 32°F to 77°F (0°C to 25°C) (104°F/40°C occasionally)

Refer to Engineering Section for details.

Approvals:

CSA certified to:

8040 Series:

- 1) Standard C22.2 No. 139 "Electrically Operated Valves," File 10381.
- 2) Automatic Gas Valves Z21.21 (6.5), File 112872.
- 3) Automatic Gas Safety Shutoff Valves C/I (3.9), File 112972.

8215 Series Normally Closed:

- 1) Standard C22.2 No. 139 "Electrically Operated Valves," File 10381.
- 2) Automatic Gas Valves Z21.21 (6.5), File 112872.

8215 Series Normally Open:

- 1) Standard C22.2 No. 139 "Electrically Operated Valves," File 10381.

UL listed, as indicated. FM approved (Normally Closed only, except Catalog Numbers 8215A90 and 8215A40). Red-Hat II meets applicable CE directives. Refer to Engineering Section for details.

Specifications (English units)

Pipe Size (ins.)	Orifice Size (ins.)	Cv Flow Factor	Gas Capacity Btu/hr ⑥	Operating Pressure Differential (psi)			Max. Fluid Temp. °F		Aluminum Body			Watt Rating/ Class of Coil Insulation ②	
				Min.	Max. AC	Max. DC	AC	DC	Catalog Number	Constr. Ref. No	UL ⑤ Listing	AC	DC
					Air-Fuel Gas	Air-Fuel Gas							
NORMALLY CLOSED (Closed when de-energized)													
1/8	5/16	1.0	53,700	0	15	-	125	-	8040H6	11	○	6.1/F	-
1/4	5/16	1.1	59,000	0	15	-	125	-	8040H7	11	○	6.1/F	-
3/8	5/16	1.2	64,400	0	15	-	125	-	8040H8	11	○	6.1/F	-
3/8	3/4	3.4	183,000	0	50	25	125	104	8215G10	2	○	10.1/F	11.6/F
3/8	3/4	3.5	-	5	125	125	125	104	8215G1 ①	1	○	6.1/F	11.6/F
1/2	3/4	5.4	291,000	0	2	-	125	-	8040G22	13A	○	10.1/F	-
1/2	3/4	4.4	238,500	0	50	25	125	104	8215G20	2	○	10.1/F	11.6/F
1/2	3/4	4.8	-	5	125	125	125	104	8215G2 ①	1	○	6.1/F	11.6/F
3/4	3/4	9.5	449,000	0	2	-	125	-	8040G23	13B	○	10.1/F	-
3/4	3/4	5.1	247,500	0	50	25	125	104	8215G30	4	○	10.1/F	11.6/F
3/4	3/4	5.1	-	5	125	125	125	104	8215G3 ①	3	○	6.1/F	11.6/F
1	1 5/8	21	1,119,000	0	25	25	125	77	8215B50 ③	6	○	15.4/F	14.9/B
1 1/4	1 5/8	32	1,730,000	0	25	25	125	77	8215B60 ③	6	○	15.4/F	14.9/B
1 1/2	1 5/8	35	1,900,000	0	25	25	125	77	8215B70 ③	6	○	15.4/F	14.9/B
2	2 3/32	60	3,251,000	0	25	15	125	77	8215B80 ③	7	○	15.4/F	14.9/B
2 1/2	3	117	5,821,000	0	5	-	125	-	8215A90	8	○	28.2/F	-
3	3	138	7,430,000	0	5	-	125	-	8215A40	8	○	28.2/F	-
NORMALLY OPEN (Open when de-energized)													
3/8	3/4	3.2	172,500	0	125	125	125	104	8215G13	9	●	10.1/F	11.6/F
1/2	3/4	4	206,250	0	125	125	125	104	8215G23	9	●	10.1/F	11.6/F
3/4	3/4	4.6	247,500	0	125	125	125	104	8215G33	10	●	10.1/F	11.6/F
1	1 5/8	22	1,191,750	0	25	15	125	77	8215C53	12	●	15.4/F	14.9/B
1 1/4	1 5/8	33	1,793,250	0	25	15	125	77	8215C63	12	●	15.4/F	14.9/B
1 1/2	1 5/8	37	1,988,250	0	25	15	125	77	8215C73	13	●	15.4/F	14.9/B
2	2 3/32	58	3,100,000	0	25	15	125	77	8215C83	14	●	15.4/F	14.9/B
2 1/2	3	117	6,290,000	0	5	-	125	-	8215B93 ④	15	●	28.2/F	-
Notes: ① Do not use for Fuel Gas. ② On 50 hertz service, the watt rating for the 6.1/F solenoid is 8.1 watts. ③ FM Approved Process Control Valves. See Engineering Section (Approvals) for details. ④ Type 1 enclosure only. ⑤ ○ = Safety Shutoff Valve; ● = General Purpose Valve. Refer to Engineering Section (Approvals) for details. ⑥ 1" W.C. Drop @ 2" W.C. Inlet Pressure, 1, 000 Btu/cu.ft. or more, 0.64 Specific Gravity Gas.													

Specifications (Metric units)

Pipe Size (ins.)	Orifice Size (mm)	Kv Flow Factor (m3/h)	Gas Capacity Btu/hr ⑥	Operating Pressure Differential (bar)			Max. Fluid Temp. °C		Aluminum Body			Watt Rating/ Class of Coil Insulation ②	
				Min.	Max. AC	Max. DC	AC	DC	Catalog Number	Constr. Ref. No	UL ⑤ Listing	AC	DC
					Air-Fuel Gas	Air-Fuel Gas							
NORMALLY CLOSED (Closed when de-energized)													
1/8	7.9	.86	53,700	0	1.0	-	51	-	8040H6	11	○	6.1/F	-
1/4	7.9	.94	59,000	0	1.0	-	51	-	8040H7	11	○	6.1/F	-
3/8	7.9	1.03	64,400	0	1.0	-	51	-	8040H8	11	○	6.1/F	-
3/8	19	2.91	183,000	0	3.4	1.7	51	40	8215G10	2	○	10.1/F	11.6/F
3/8	19	3.00	-	0.3	8.6	8.6	51	40	8215G1 ①	1	○	6.1/F	11.6/F
1/2	19	4.63	291,000	0	0.1	-	51	-	8040G22	13A	○	10.1/F	-
1/2	19	3.77	238,500	0	3.4	1.7	51	40	8215G20	2	○	10.1/F	11.6/F
1/2	19	4.11	-	0.3	8.6	8.6	51	40	8215G2 ①	1	○	6.1/F	11.6/F
3/4	19	8.14	449,000	0	0.1	-	51	-	8040G23	13B	○	10.1/F	-
3/4	19	4.37	247,500	0	3.4	1.7	51	40	8215G30	4	○	10.1/F	11.6/F
3/4	19	4.37	-	0.3	8.6	8.6	51	40	8215G3 ①	3	○	6.1/F	11.6/F
1	41	18.00	1,119,000	0	1.7	1.7	51	25	8215B50 ③	6	○	15.4/F	14.9/B
1 1/4	41	27.43	1,730,000	0	1.7	1.7	51	25	8215B60 ③	6	○	15.4/F	14.9/B
1 1/2	41	30.00	1,900,000	0	1.7	1.7	51	25	8215B70 ③	6	○	15.4/F	14.9/B
2	53	51.43	3,251,000	0	1.7	1.0	51	25	8215B80 ③	7	○	15.4/F	14.9/B
2 1/2	76	100.28	5,821,000	0	0.3	-	51	-	8215A90	8	○	28.2/F	-
3	76	118.28	7,430,000	0	0.3	-	51	-	8215A40	8	○	28.2/F	-
NORMALLY OPEN (Open when de-energized)													
3/8	19	2.74	172,500	0	8.6	8.6	51	40	8215G13	9	●	10.1/F	11.6/F
1/2	19	3.43	206,250	0	8.6	8.6	51	40	8215G23	9	●	10.1/F	11.6/F
3/4	19	3.94	247,500	0	8.6	8.6	51	40	8215G33	10	●	10.1/F	11.6/F
1	41	18.86	1,191,750	0	1.7	1.0	51	25	8215C53	12	●	15.4/F	14.9/B
1 1/4	41	28.28	1,793,250	0	1.7	1.0	51	25	8215C63	12	●	15.4/F	14.9/B
1 1/2	41	31.71	1,988,250	0	1.7	1.0	51	25	8215C73	13	●	15.4/F	14.9/B
2	53	49.71	3,100,000	0	1.7	1.0	51	25	8215C83	14	●	15.4/F	14.9/B
2 1/2	76	100.28	6,290,000	0	0.3	-	51	-	8215B93 ④	15	●	28.2/F	-
Notes: ① Do not use for Fuel Gas. ② On 50 hertz service, the watt rating for the 6.1/F solenoid is 8.1 watts. ③ FM Approved Process Control Valves. See Engineering Section (Approvals) for details. ④ Type 1 enclosure only. ⑤ ○ = Safety Shutoff Valve; ● = General Purpose Valve. Refer to Engineering Section (Approvals) for details. ⑥ 1" W.C. Drop @ 2" W.C. Inlet Pressure, 1,000 Btu/cu.ft. or more, 0.64 Specific Gravity Gas.													

Dimensions: inches (mm)

Constr. Ref. No.		H	K	L	P	W
1	ins.	3.42	2.00	2.75	2.87	2.46
	mm	87	51	70	73	63
2	ins.	4.02	2.49	2.75	3.46	2.46
	mm	102	63	70	88	63
3	ins.	3.87	2.19	3.31	3.05	2.33
	mm	98	56	84	77	59
4	ins.	4.46	2.68	3.31	3.64	2.33
	mm	113	68	84	92	59
6 ①	ins.	6.84	x	5.00	5.59	5.38
	mm	174	x	127	142	137
7 ①	ins.	7.47	x	6.09	5.94	6.31
	mm	190	x	155	151	160
8 ①	ins.	10.25	x	7.79	7.91	7.94
	mm	260	x	198	201	202
9	ins.	4.42	2.72	2.75	3.86	2.36
	mm	112	69	70	98	60
10	ins.	4.86	2.72	3.31	4.04	2.36
	mm	123	69	84	103	60
11	ins.	2.74	1.44	2.00	2.30	1.69
	mm	69	36	51	58	43
12	ins.	6.84	x	5.00	3.63	5.38
	mm	174	x	127	92	137
13	ins.	6.84	x	5.00	3.56	5.38
	mm	174	x	127	90	137
13A	ins.	4.05	2.46	2.75	3.44	2.42
	mm	103	63	70	87	62
13B	ins.	4.49	2.65	3.31	3.63	2.39
	mm	114	67	84	92	61
14 ②	ins.	7.44	x	6.09	3.81	6.31
	mm	189	x	155	97	160
15 ②	ins.	10.25	x	7.80	5.22	7.94
	mm	260	x	198	133	202

IMPORTANT: Valves may be mounted in any position except all DC constructions and those marked ①, which must be mounted with the solenoid vertical and upright. Constructions marked ② must be mounted with the solenoid vertical and upright or horizontal only.

Constr. Refs. 1-4, 9, 10, 13a, 13b

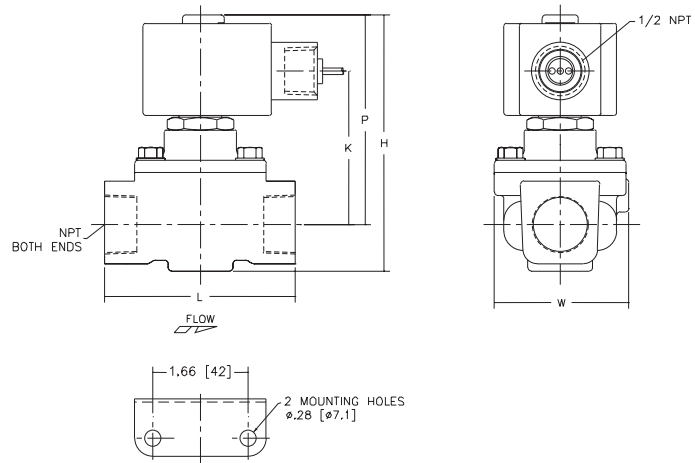

Constr. Refs. 6, 7, 8, 12-15

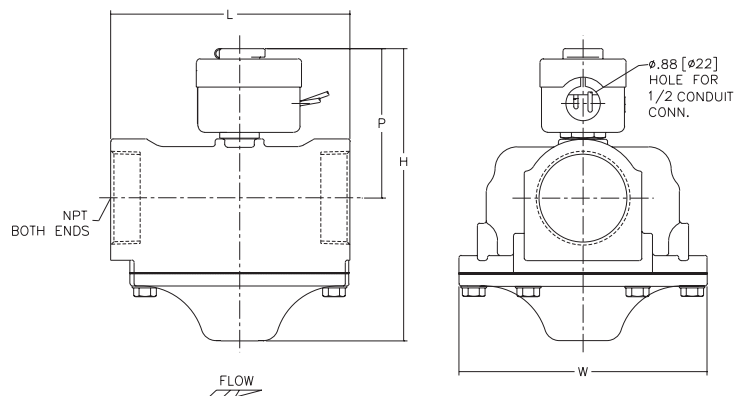

Constr. Refs. 11

