

Features

- Rugged piston construction built to withstand pressure ratings of 450 to 1500 psi.
- Angle body design for high flows.
- Ideal for high pressure water applications, such as car washes.
- Mountable in any position.

Construction

Valve Parts in Contact with Fluids		
Body	Brass	300 Stainless Steel
Seals and Disc	NBR, PA, PTFE	PTFE, NBR
Core Tube	305 Stainless Steel	
Core and Plugnut	430F Stainless Steel	
Core Spring	302 Stainless Steel	
Shading Coil	Copper	Silver
Stem	PA (Normally Open)	

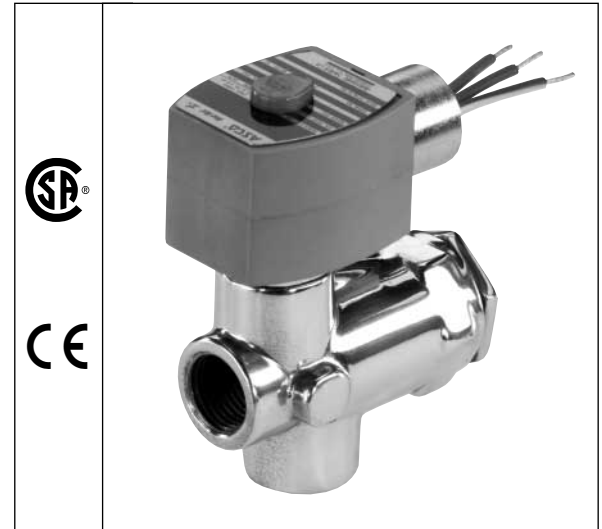

Electrical

Standard Coil and Class of Insulation	Watt Rating and Power Consumption				Spare Coil Part Number			
	DC Watts	AC			General Purpose		Explosionproof	
		Watts	VA Holding	VA Inrush	AC	DC	AC	DC
F	-	10.1	25	50	238610	-	238614	-
F	22.6	17.1	40	70	238610	238710	238614	238714

Standard Voltages: 24, 120, 240, 480 volts AC, 60 Hz (or 110, 220 volts AC, 50 Hz). 6, 12, 24, 120, 240 volts DC. Must be specified when ordering. Other voltages available when required.

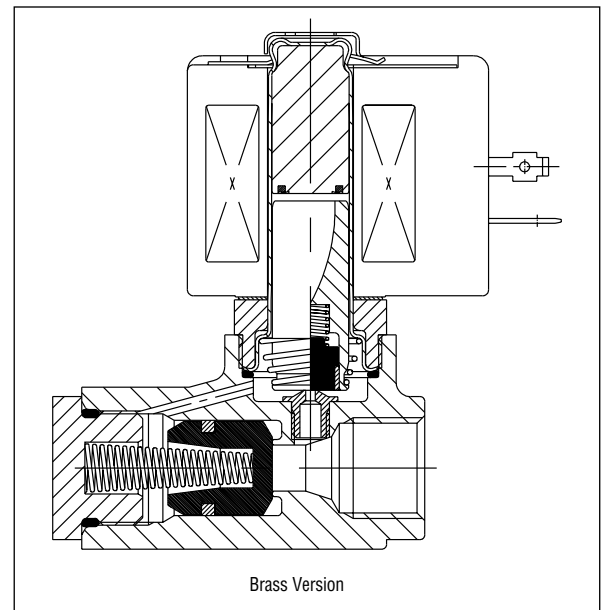

Solenoid Enclosures

Standard: Watertight, Types 1, 2, 3, 3S, 4, and 4X.
Optional: Explosionproof and Watertight, Types 3, 3S, 4, 4X, 6, 6P, 7, and 9. (To order, add prefix "EF" to catalog number.)
See Optional Features Section for other available options.

Nominal Ambient Temperature Ranges:

AC: 32°F to 125°F (0°C to 52°C)

DC: 32°F to 104°F (0°C to 40°C)

Refer to Engineering Section for details.

Approvals:

CSA certified. Meets applicable CE directives.

Refer to Engineering Section for details.

Specifications (English units)

Pipe Size (ins.)	Orifice Size (ins.)	Cv Flow Factor	Operating Pressure Differential (psi)							Maximum Fluid Temp. °F		Brass Body		Stainless Steel Body		Watt Rating/Class of Coil Insulation	
			Min.	Max. AC			Max. DC			AC	DC	Catalog Number	Constr. Ref. No.	Catalog Number	Constr. Ref. No.	AC	DC
				Air-Inert Gas	Water	Light Oil @ 300 SSU	Air-Inert Gas	Water	Light Oil @ 300 SSU								
NORMALLY CLOSED (Closed when de-energized)																	
1/4	5/16	1.5	10	750	750	750	-	-	-	200	-	8223G21	1	-	-	10.1/F	-
1/4	5/16	1.5	10	1500	1500	1500	500	500	500	200	150	8223G25	1	-	-	17.1/F	22.6/F
3/8	5/16	1.5	10	750	750	750	400	400	400	200	150	8223G23	1	-	-	10.1/F	22.6/F
3/8	5/16	1.5	10	1500	1500	1500	500	500	500	200	150	8223G27	1	-	-	17.1/F	22.6/F
1/2	3/8	3.2	25	1500	1500	1500	500	500	500	200	150	8223G3	2	8223G10	4	17.1/F	22.6/F
3/4	3/4	7.8	25	750	750	750	450	450	450	200	150	8223G5	3	8223G12	5	17.1/F	22.6/F

Specifications (Metric units)

Pipe Size (ins.)	Orifice Size (mm)	Kv Flow Factor (m3/h)	Operating Pressure Differential (bar)							Maximum Fluid Temp. °C		Brass Body		Stainless Steel Body		Watt Rating/Class of Coil Insulation	
			Min.	Max. AC			Max. DC			AC	DC	Catalog Number	Constr. Ref. No.	Catalog Number	Constr. Ref. No.	AC	DC
				Air-Inert Gas	Water	Light Oil @ 300 SSU	Air-Inert Gas	Water	Light Oil @ 300 SSU								
NORMALLY CLOSED (Closed when de-energized)																	
1/4	8	1.29	0.7	52	52	52	-	-	-	92	-	8223G21	1	-	-	10.1/F	-
1/4	8	1.29	0.7	103	103	103	34	34	34	92	65	8223G25	1	-	-	17.1/F	22.6/F
3/8	8	1.29	0.7	52	52	52	28	28	28	92	65	8223G23	1	-	-	10.1/F	22.6/F
3/8	8	1.29	0.7	103	103	103	34	34	34	92	65	8223G27	1	-	-	17.1/F	22.6/F
1/2	10	2.74	1.7	103	103	103	34	34	34	92	65	8223G3	2	8223G10	4	17.1/F	22.6/F
3/4	19	6.69	1.7	52	52	52	31	31	31	92	65	8223G5	3	8223G12	5	17.1/F	22.6/F

Dimensions: inches (mm)

Constr. Ref. No.		H	K	L	P	W
1	ins.	3.41	1.91	2.44	2.88	1.95
	mm	87	49	62	73	50
2	ins.	4.32	2.17	3.03	3.13	1.95
	mm	110	55	77	80	50
3	ins.	5.03	2.64	3.60	3.61	2.00
	mm	128	67	91	92	51
4	ins.	4.34	2.15	2.50	3.13	1.95
	mm	110	55	64	80	50
5	ins.	5.03	2.53	3.53	3.50	3.50
	mm	128	64	90	89	89

Constr. Refs. 1 - 5