

General Description

These 2-way normally closed valve bodies are designed for on/off control of commercial or industrial gas burners. The V710(B) is designed exclusively for use with the AH(E) Hydramotor® actuator. The AH(E) Hydramotor valve consists of two assemblies; the V710(B) valve body and the AH(E) Hydramotor actuator.

The V710(B) is a push-to-open valve which opens when the valve stem is depressed by an AH(E) Hydramotor. An internal return spring closes the valve when the Hydramotor actuator is de-energized. Optional flange adapters are available for ease of installation and service. These valves are provided with upstream and downstream pipe taps with plugs for routine testing.

Fluid

Fuel Gas

Construction

Valve Parts in Contact with Fluids	
Body	Die-cast aluminum
Bonnet	Die-cast aluminum
Seals	Nitrile
Springs	Zinc-plated steel
Stem Bushing	Delrin
Valve Stem	303 stainless steel
Discs	NBR
Retaining Ring	303 stainless steel
Pipe Plugs	Zinc-plated steel
Seal Ring	PTFE (models with overtravel)
Stem Connector	303 stainless steel

Model Types

Quick Opening Trim: (Standard)

For applications where metered flow control is not required.

Quick Opening w/Valve Seal Overtravel Trim: (Suffix V22)

For any "on-off" application where the user, code or approval agency requires a valve seal overtravel arrangement.

Linear Trim: (Suffix V15)

For applications that require flow control, such as slow opening, or low fire turn down

Linear w/Valve Seal Overtravel Trim: (Suffix V25)

For applications where both valve seal overtravel and flow control are required. (Not available in 4" flange size).

Closeoff Pressure

50 psi (3.5 bar) maximum



Series V710(B) valve body with AH(E) Hydramotor

Installation

V710(B) valve body mounts in any position directly to AH(E) Hydramotor Actuator.



Approvals

V710(B) valve with AH(E) Hydramotor

UL listed to standard 429 "Electrically Operated Valves," Guide Y10Z, File MP932 Safety Valves

FM Approved to Class 7400 "liquid and gas safety shutoff valves."

CSA Certified to:

1. Automatic Gas Valves ANSI Z21.21 CSA 6.5, C/I, File 109157 and 113070.
2. Automatic Gas Safety Shutoff Valves (CGA 3.9), File 113070
3. Standard C22.2 No. 139, File 109157 and 113070

Ordering Information

Important: Order by Catalog Number and add suffix number for desired optional feature. e.g. V710EBSV22

Specifications (English units) - with AH2E Actuator Only

Pipe Size (ins.)	Orifice Size (ins.)	Cv Flow Factor	Flow Capacity ft ³ /hr ⓐ	Gas Capacity Btu/hr. ①	Operating Pressure Differential (psi)		Fluid Temp. °F		Catalog Numbers		Const. Ref.	Approx. Shipping Weight (lbs)
					Min.	Max.	Min.	Max.	Quick Opening Trim	Quick Opening w/Valve Seal Overtravel Trim		
COMBUSTION (Fuel Gas) - Normally Closed												
3/4	1 5/8	14	755	754,900	0	15	-40	150	V710EBS	V710EBSV22	1	4.3
1	1 5/8	20	1,078	1,078,400	0	15	-40	150	V710FBS	V710FBSV22	1	4.2
1 1/4	2 3/32	44	2,353	2,353,000	0	15	-40	150	V710GBS	V710GBSV22	2	6.3
1 1/2	2 3/32	57	3,048	3,048,000	0	15	-40	150	V710HBS	V710HBSV22	2	6.1
2	2 3/32	74	3,956	3,956,500	0	15	-40	150	V710JBS	V710JBSV22	2	5.8
2 (High Flow)	3	91	4,906	4,906,800	0	15	-40	150	V710MBS	V710MBSV22	3	13.2
2 1/2	3	120	6,470	6,470,500	0	15	-40	150	V710KBS	V710KBSV22	3	12.7
3	3	160	8,627	8,627,300	0	15	-40	150	V710LBS	V710LBSV22 ②	3	11.7
4 (Flange)	4	180	10,200	10,200,000	0	15	-40	150	V710NCF	V710NCFV22	4	100

① 1" W.C. Drop @ 2" W.C. Inlet Pressure, 1,000 Btu/cu.ft. or more, 0.64 Specific Gravity Gas. ② Cv flow factor is 149.

Specifications (Metric units) - with AH2E Actuator Only

Pipe Size (ins.)	Orifice Size (mm)	Kv Flow Factor	Flow Capacity m ³ /hr ⓐ	Gas Capacity Btu/hr. ①	Operating Pressure Differential (bar)		Fluid Temp. °C		Catalog Numbers		Const. Ref.	Approx. Shipping Weight (kgs)
					Min.	Max.	Min.	Max.	Quick Opening Trim	Quick Opening w/Valve Seal Overtravel Trim		
COMBUSTION (Fuel Gas) - Normally Closed												
3/4	41	12.1	21	754,900	0	1	-40	66	V710EBS	V710EBSV22	1	2.0
1	41	17.3	31	1,078,400	0	1	-40	66	V710FBS	V710FBSV22	1	1.9
1 1/4	53	38	67	2,353,000	0	1	-40	66	V710GBS	V710GBSV22	2	2.9
1 1/2	53	49	86	3,048,000	0	1	-40	66	V710HBS	V710HBSV22	2	2.8
2	53	64	112	3,956,500	0	1	-40	66	V710JBS	V710JBSV22	2	2.6
2 (High Flow)	76	79	139	4,906,800	0	1	-40	66	V710MBS	V710MBSV22	3	6.0
2 1/2	76	104	183	6,470,500	0	1	-40	66	V710KBS	V710KBSV22	3	5.8
3	76	138	244	8,627,300	0	1	-40	66	V710LBS	V710LBSV22 ②	3	5.3
4 (Flange)	102	156	289	10,200,000	0	1	-40	66	V710NCF	V710NCFV22	4	45.5

① 1" W.C. Drop @ 2" W.C. Inlet Pressure, 1,000 Btu/cu.ft. or more, 0.64 Specific Gravity Gas. ② Kv flow factor is 129.

COMBUSTION

Trim Types

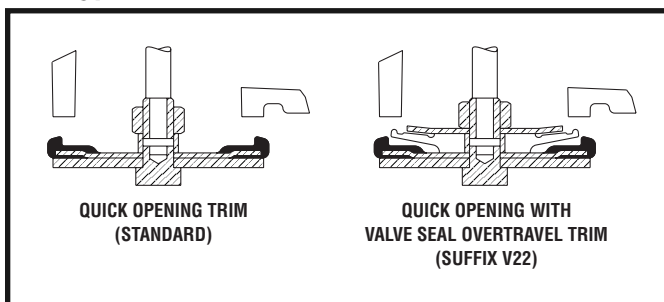

Specifications (English units) - with AH4E Actuator Only

Pipe Size (ins.)	Orifice Size (ins.)	Cv Flow Factor	Flow Capacity ft ³ /hr Ⓞ	Gas Capacity Btu/hr. ①	Operating Pressure Differential (psi)		Fluid Temp. °F		Catalog Numbers		Const. Ref.	Approx. Shipping Weight (lbs)
					Min.	Max.	Min.	Max.	Linear Trim	Linear w/Valve Seal Overtravel Trim		
COMBUSTION (Fuel Gas) - Normally Closed												
3/4	1 5/8	13	695	695,100	0	15	-40	150	V710EBSV15	V710EBSV25	1	4.3
1	1 5/8	19	1016	1,016,000	0	15	-40	150	V710FBSV15	V710FBSV25	1	4.2
1 1/4	2 3/32	42	2246	2,246,000	0	15	-40	150	V710GBSV15	V710GBSV25	2	6.3
1 1/2	2 3/32	52	2780	2,780,300	0	15	-40	150	V710HBSV15	V710HBSV25	2	6.1
2	2 3/32	67	3582	3,582,300	0	15	-40	150	V710JBSV15	V710JBSV25	2	5.8
2 (High Flow)	3	88	4705	4,705,100	0	15	-40	150	V710MBSV15	V710MBSV25	3	13.2
2 1/2	3	104	5561	5,561,000	0	15	-40	150	V710KBSV15	V710KBSV25	3	12.7
3	3	128	6844	6,844,000	0	15	-40	150	V710LBSV15	V710LBSV25 ②	3	11.7
4 (Flange)	4	180	10,200	10,200,000	0	15	-40	150	V710NCFV15	-	4	100

① 1" W.C. Drop @ 2" W.C. Inlet Pressure, 1,000 Btu/cu.ft. or more, 0.64 Specific Gravity Gas. ② Cv flow factor is 124.

Specifications (Metric units) - with AH4E Actuator Only

Pipe Size (ins.)	Orifice Size (mm)	Kv Flow Factor	Flow Capacity m ³ /hr Ⓞ	Gas Capacity Btu/hr. ①	Operating Pressure Differential (bar)		Fluid Temp. °C		Catalog Numbers		Const. Ref.	Approx. Shipping Weight (kgs)
					Min.	Max.	Min.	Max.	Linear Trim	Linear w/Valve Seal Overtravel Trim		
COMBUSTION (Fuel Gas) - Normally Closed												
3/4	41	11.3	20	695,100	0	1	-40	66	V710EBSV15	V710EBSV25	1	2.0
1	41	16.4	29	1,016,000	0	1	-40	66	V710FBSV15	V710FBSV25	1	1.9
1 1/4	53	36	64	2,246,000	0	1	-40	66	V710GBSV15	V710GBSV25	2	2.9
1 1/2	53	45	79	2,780,300	0	1	-40	66	V710HBSV15	V710HBSV25	2	2.8
2	53	58	101	3,582,300	0	1	-40	66	V710JBSV15	V710JBSV25	2	2.6
2 (High Flow)	76	76	133	4,705,100	0	1	-40	66	V710MBSV15	V710MBSV25	3	6.0
2 1/2	76	90	157	5,561,000	0	1	-40	66	V710KBSV15	V710KBSV25	3	5.8
3	76	111	194	6,844,000	0	1	-40	66	V710LBSV15	V710LBSV25 ②	3	5.3
4 (Flange)	102	156	289	10,200,000	0	1	-40	66	V710NCFV15	-	4	45.5

① 1" W.C. Drop @ 2" W.C. Inlet Pressure, 1,000 Btu/cu.ft. or more, 0.64 Specific Gravity Gas. ② Kv flow factor is 107.

Trim Types

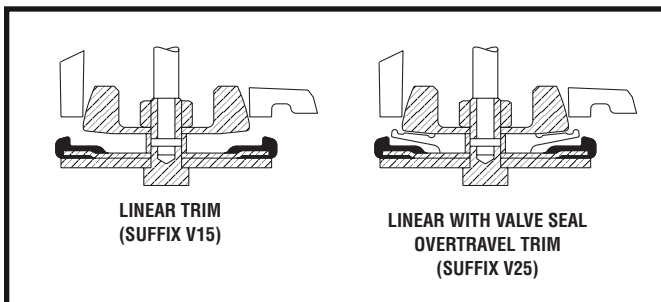

Dimensions inches (mm)

Const. Ref.		A	B	C	D
1	ins.	5.3	3.48	1.46	5.39
	mm	135	88	37	137
2	ins.	6.09	3.83	1.89	6.32
	mm	155	97	48	161
3	ins.	7.80	5.28	2.38	7.94
	mm	198	134	60	202
4	ins.	13.88	5	7.40	9
	mm	353	127	188	229

Const. Ref. 1-3

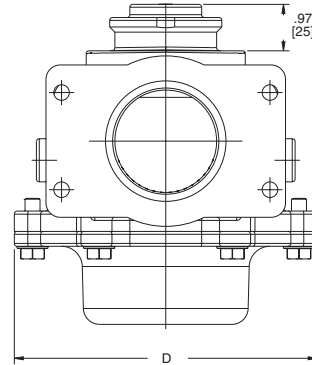
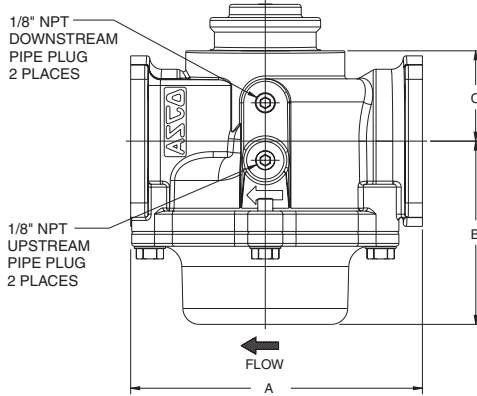

Const. Ref. 4

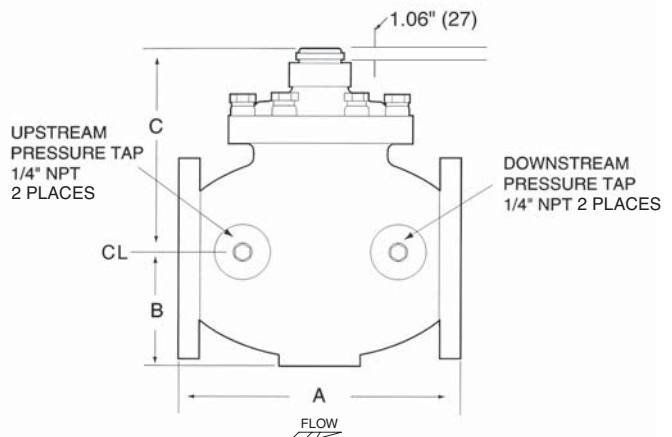

Flange Adapters

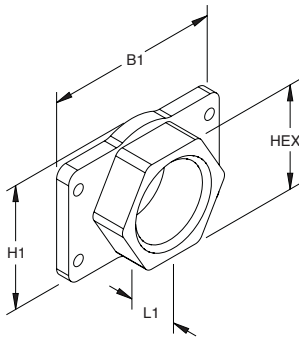

Flange Adapter Kits (Optional)*

Flange Adapters		B1	H1	L1	HEX
3/4" - 1"	ins.	4.8	2.5	1.27	2.5
	mm	122	76	32	64
1 1/4" - 2"	ins.	5	3.56	1.38	3
	mm	127	90	35	76
2" (High Flow) - 3"	ins.	7	4.5	2.015	4.5
	mm	178	114	51	114

Pipe Size (ins.)	Inlet & Outlet Adapter/Hardware Kit
3/4	296659-001
1	296659-002
1 1/4	296659-005
1 1/2	296659-006
2	296659-007
2 (High Flow)	296659-008
2 1/2	296659-009
3	296659-010

* Please refer to the Double Gas Shutoff Valves catalog pages for more kit information.