

Product Identification and Overview

- Field Replaceable Electrochemical Sensor with Self-Test
- Optional BACnet MS/TP Output of CO, Temp and Humidity
- Field Selectable Voltage Outputs
- Certificate of Calibration Included with Sensors and Replacement Modules

BAPI's Carbon Monoxide Rough Service Sensor offers enhanced electrochemical sensing with outstanding accuracy at low concentrations. It features a ventilated BAPI-Box and is ideal for parking ramps, equipment rooms and warehouses.

The sensor has a CO range of 0 to 500 ppm with field selectable outputs of 0 to 5, 1 to 5, 0 to 10 and 2 to 10 VDC. It includes optional humidity measurement with one of the above voltage outputs, and temperature via a 10K-2, 10K-3 or 20K Thermistor. The CO, temperature and humidity outputs are also available via BACnet MS/TP.

The field replaceable sensor element lasts approximately 7 years and is self-tested daily.



CO Rough Service Sensors
(Bottom unit shown with temp and %RH sensing)



Mounting

1. Mount the unit on a solid, non-vibrating surface 3 to 5 feet above floor level. Mount in a horizontal orientation with the enclosure hinge at the top as shown in Fig 2. Failure to do so may degrade the life of the sensor element. Do not mount near supply or return diffusers.
2. Use BAPI recommended #10 (M5) screws on the four mounting feet of the enclosure. A pilot-hole makes mounting easier. Use the enclosure mounting feet to mark the pilot-hole locations.
3. Snug up the screws so that the foam backing is depressed but do not over-tighten or strip the screw threads.
4. Place the provided #6 screws into the holes on each side of the lid latch to make the cover tamper resistant.

Fig. 1: Screw Hole Template. Drill center 7/8" hole for rear conduit entry.

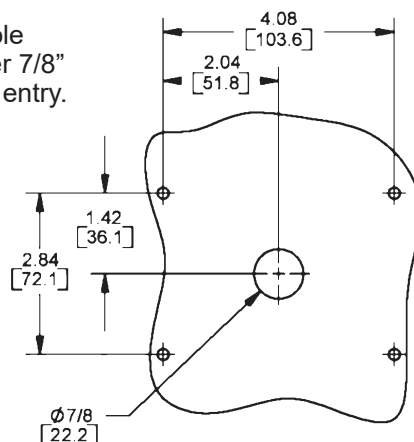
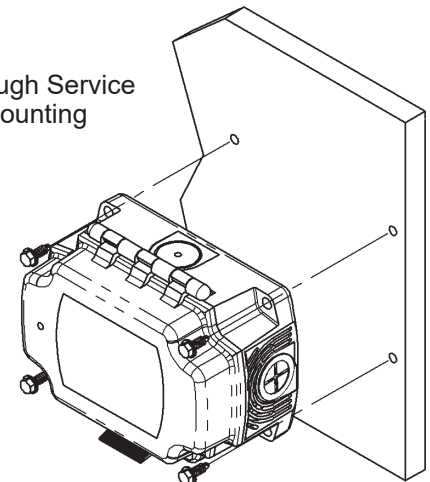

Fig. 2: Rough Service Unit mounting



Specifications subject to change without notice.



Rough Service Carbon Monoxide with Optional BACnet

Installation & Operating Instructions

43593_ins_CO_V_BB_BACnet

rev. 07/21/21

Termination

BAPI recommends using twisted pair of at least 22AWG and sealant filled connectors for all wire connections. Larger gauge wire may be required for long runs. All wiring must comply with the National Electric Code (NEC) and local codes.

Do NOT run this device's wiring in the same conduit as AC power wiring of NEC class 1, NEC class 2, NEC class 3 or with wiring used to supply highly inductive loads such as motors, contactors and relays. BAPI's tests show that fluctuating and inaccurate signal levels are possible when AC power wiring is present in the same conduit as the signal lines. If you are experiencing any of these difficulties, please contact your BAPI representative.



BAPI recommends wiring the product with power disconnected. Proper supply voltage, polarity and wiring connections are important to a successful installation. Not observing these recommendations may damage the product and void the warranty.

WIRE TERMINATIONS

PWR (Red)

0 to 5 or 1 to 5 VDC Output
9 to 40 VDC, 10 mA Max
12 to 28 VAC, 1.4 VA Max

0 to 10 or 2 to 10 VDC Output
12 to 40 VDC, 10 mA Max
12 to 28 VAC, 1.4 VA Max

BACnet Output
9 to 40 VDC, 35 mA Max
12 to 28 VAC, 1.7 VA Max

GND (Black)

Power and Analog Output Ground

CO (Orange)

Analog Output CO PPM Level (if enabled)

RH (Green)

Analog Output %RH Level (if enabled)

Temp (Varies)

Resistive Sensor Output (if enabled)

A+/B- (Blue/White)

BACnet RS-485

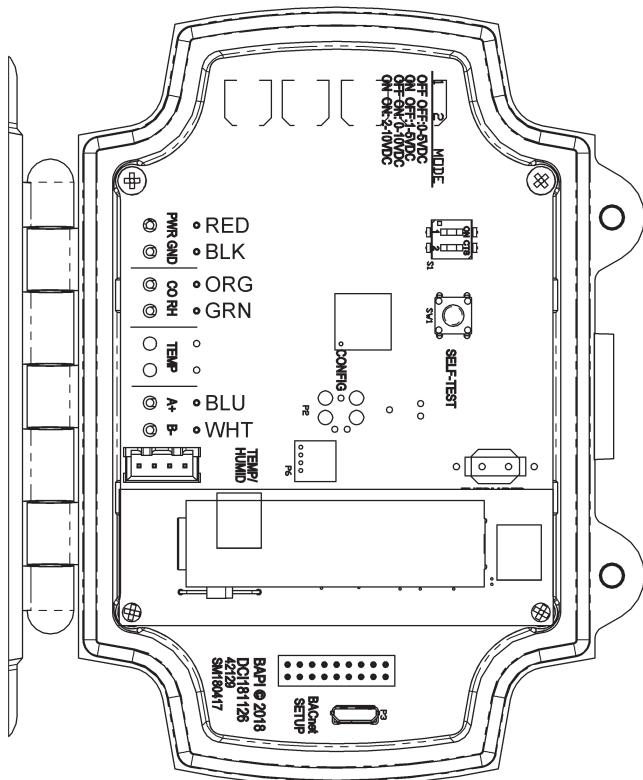

Fig. 3: Field Wiring Terminals

Connecting Multiple CO Transmitters on the Same RS485 Line (BACnet Only)

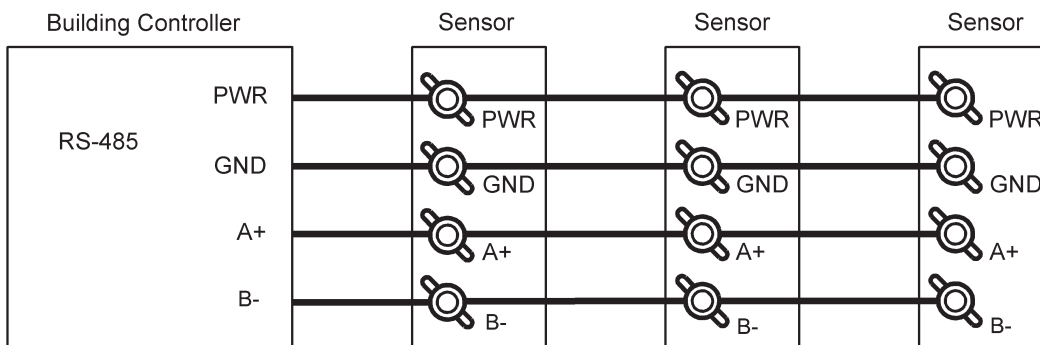

Fig. 4: Multiple CO transmitters connected to the same RS-485 Line

Specifications subject to change without notice.

Keeping the Enclosure Air Tight After Termination

For the sensor to work correctly, the wiring entrance must remain air tight. If the CO unit is mounted to a hollow wall and wired through its back, or wired with conduit, it is possible that a draft of clean air may fill the enclosure through the wiring opening. This draft may prevent the unit from measuring ambient Carbon Monoxide. BAPI recommends either a liquid-tight fitting or plugging the conduit at the enclosure.

- **Liquid-Tight Fitting** – BAPI’s Liquid-Tight Fitting (BA/LTF) allows wire cables of 0.1 to 0.3 inch outside diameter to enter the box. Tightening the collar onto the wire cable keeps the wiring entrance air tight.
- **Conduit** – Included with the Carbon Monoxide transmitter is a foam plug to seal the ½ inch EMT. Place the wires into the plug as shown in Fig. 5 and then insert the plug into the conduit sealing the conduit.

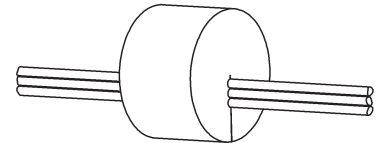

Fig. 5:
Wires Through Foam Plug

Operation

The unit includes two switches to set the analog output voltage for the CO and optional %RH output for non-BACnet units. The unit also includes a self-test button to perform the sensor self-test. A micro-USB port allows configuration of the BACnet settings via PC application.

ANALOG OUTPUT CONFIGURATION SWITCHES

Switches one and two of S1 are used to set the analog output voltage for the CO and optional %RH output for non-BACnet units. Available outputs are 0 to 5V, 1 to 5V, 0 to 10V and 2 to 10V. See Table 1 at right for switch settings.

Output	Switch 1	Switch 2
0 to 5V	Off	Off
1 to 5V	On	Off
0 to 10V	Off	On
2 to 10V	On	On

Table 1:
Analog Output Switches

POWER UP

On initial power up, the unit performs a self-test to assure that the replaceable CO Sensor Module is not at the end of its life. This self-test typically takes approximately 45 seconds, and during this time, the green LED will blink slowly. Under certain circumstances, the self-test may take up to 13 minutes. When the self-test is complete, the green LED will go to a steady “on” state and the unit will be fully operational.

SELF-TEST BUTTON

The unit automatically conducts a self-test once every day, but the button allows additional testing if desired. Push and hold the button for 2 seconds to put the unit into self-test mode which checks whether the CO Sensor Module is at the end of its life and needs replacing. The green LED will begin to blink slowly, indicating that the unit is in self-test mode. The self-test typically takes up to 45 seconds, but under certain circumstances may take up to 13 minutes. When the self-test is complete, the green LED will go to a steady “on” state, indicating that there are no fault conditions. If the red LED and green LED both blink slowly, this indicates that the CO Sensor Module is at end of life and should be replaced.

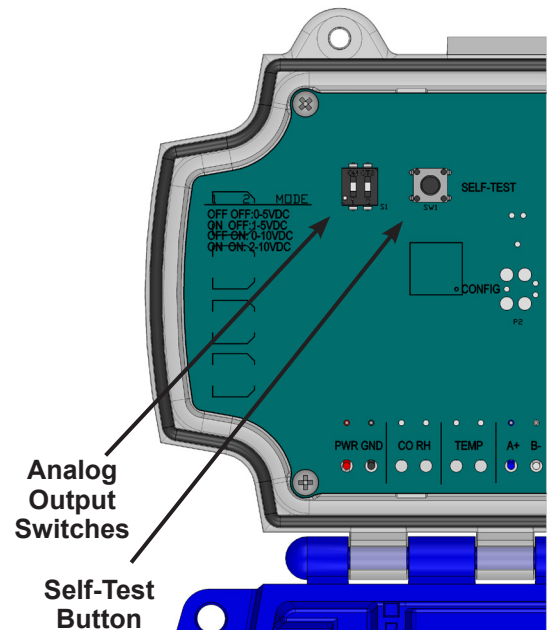

Fig. 6:
Self-Test Button and Analog Output Switches Location

Status LEDs

The green and red Status LEDs are visible through the clear cover of the unit and indicate various sensor conditions as listed below.

Green LED	Red LED	Status
Solid	Off	Power is applied and there are no fault conditions.
Blinking Slow	Off	Running a self-test.
Off	Blinking Fast	The unit had detected an output ground fault of either the CO or %RH sensors.
Off	Blinking Slow	CO alarm condition (CO PPM level is above 300 ppm)
Blinking Slow	Blinking Slow	The CO sensor is at the end of life (see CO Sensor Module Replacement section below) or either the CO or %RH sensor has been disconnected (reconnect the sensor and cycle power to clear the alert). Either condition sends the CO analog output to its max value until power is cycled.

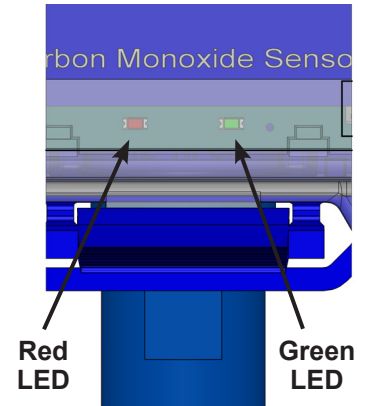

Fig. 7: Status LED Location

CO Sensor Module Replacement

Every BAPI Carbon Monoxide unit is factory calibrated and ready for operation after installation. The unit is not capable of field calibration.

BAPI recommends replacing the CO Sensor Module whenever the "Replace Sensor" alarm is active, every 7 years or at the recalibration intervals required by the local jurisdiction. Each CO Sensor Module comes with a calibration certificate.

To replace the CO Sensor Module, follow these steps;

- Remove the tamper resistant screws and open the unit's lid.
- Remove power.
- Remove the two screws from the CO Sensor Module.
- For the next two steps, hold the sensor on the CO Sensor Module by the body, not the endcaps.
- Remove the CO Sensor Module by pulling it straight off the transmitter.
- Plug in the new CO Sensor Module by aligning the Module's connector pins with the matching holes on the main circuit board and pushing the module straight into the main circuit board.
- Replace the two screws on the CO Sensor Module.
- Re-apply power.
- Close the lid until it clicks, and replace the tamper resistant screws.

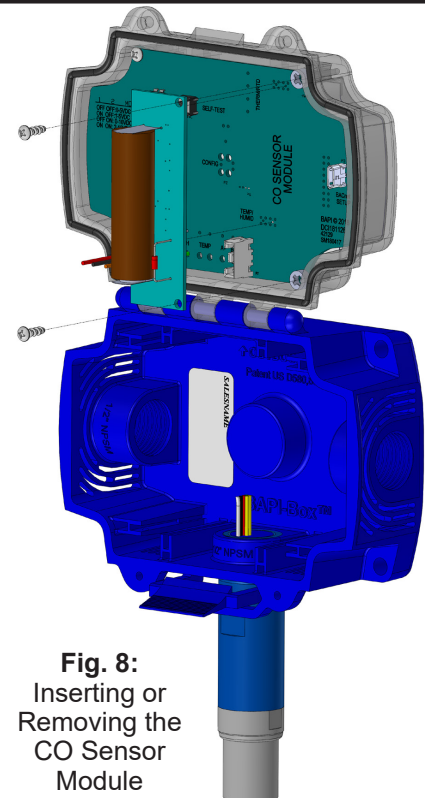

Fig. 8:
Inserting or
Removing the
CO Sensor
Module

Maintenance

The unit should be vacuumed clean once a year or more, depending on the rate of accumulation of any dust or dirt. To avoid sensor damage, the unit **MUST NOT** be submerged in any liquids. Hosing or splashing of the unit with any liquids must also be avoided and may void the warranty.

The sensor on the CO Sensor Module typically has a life of over 7 years. When the sensor reaches the end of its useful life, the unit will give an alarm indication that the CO Sensor Module needs replacement. Factory calibrated replacement modules are available from BAPI.

Specifications subject to change without notice.



BACnet Network Parameter Utility

The BACnet parameters of BACnet-enabled units can be set via a PC connection and the BACnet Network Parameter Utility. The utility can be downloaded from the Rough Service CO unit webpage on the BAPI website.

After the utility is downloaded, connect a micro-USB cable from your PC to the USB connection on the target CO unit. The USB connection will power the unit to allow configuration without external power supplied.

Once the CO sensor is connected to the utility, a screen will open similar to the one shown in Fig 9. This screen allows users to set the following parameters:

- Address
- Baud Rate
- APDU Timeout
- Number of ADPU Retries
- Device Name
- Device Instance

When the desired changes have been entered on the screen, click submit to send those changes to the unit.

Below is a list of the BACnet Object IDs (Also included in the PICS Doc):

- Temperature (Analog-Input, 0)
 - Humidity (Analog-Input, 1)
 - CarbMon (Analog-Input, 6)
 - EOL0 (Binary-Input, 1)
- (EOL0 is triggered by an End of Life alarm for the CO sensor, or another fault condition. See the "Status LEDs" section on pg. 4 for a list of fault conditons)

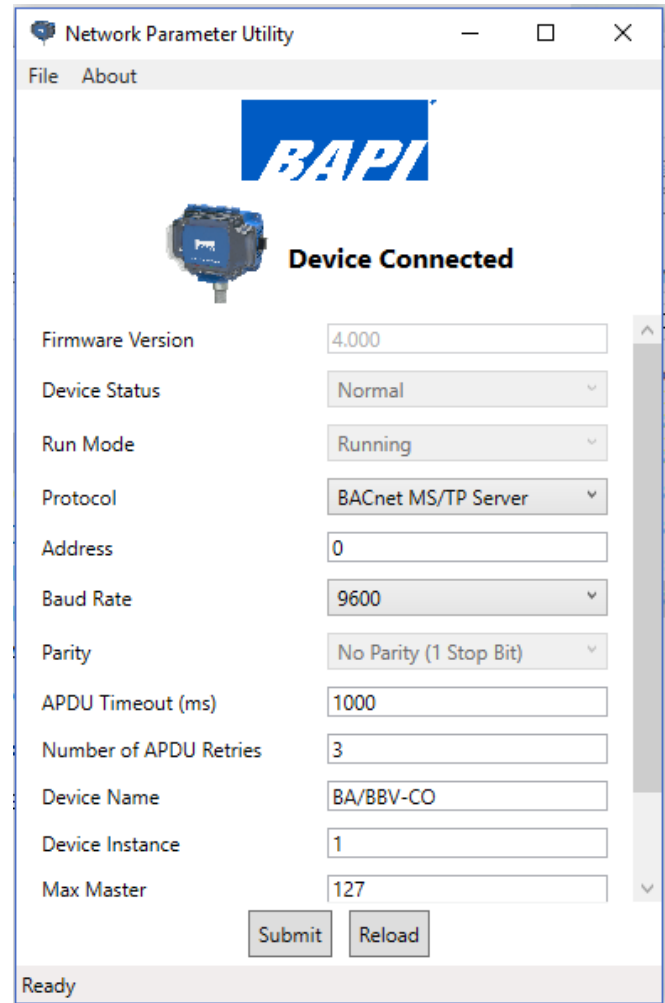

Fig. 9: BACnet Network Parameter Utility screen

Specifications

Power:

0 to 5 or 1 to 5 VDC Output
 9 to 40 VDC, 10 mA Max
 12 to 28 VAC, 1.4 VA Max

0 to 10 or 2 to 10 VDC Output
 12 to 40 VDC, 10 mA Max
 12 to 28 VAC, 1.4 VA Max

BACnet Output

9 to 40 VDC, 35 mA Max
 12 to 28 VAC, 1.7 VA Max

CO Measurement Range: 0 to 500 ppm

Field Wiring Terminals:

Flying Leads, 22 AWG

Response Time:

<80 seconds from 10% to 90% of range

Sensor Element Life: 7 Years Typical

Field Selectable Voltage Outputs

0 to 5, 1 to 5, 0 to 10 and 2 to 10 VDC

Carbon Monoxide Sensor Accuracy:

<200ppm = ±3% FS, 32 to 122°F (0 to 50°C)
 201 to 500 ppm = ±5% FS, 50 to 122°F (10 to 50°C)

Temperature Sensor Accuracy:

BACnet Units: ±0.3°C from -40 to 257°F (-40 to 125°C)
 Thermistor Units: See "Sensors" section for specs

Humidity Sensor Accuracy:

±2% RH (20% to 80%) @ 25°C, Fully Compensated

Environmental Operation Range

Continuous: 32 to 122°F (0 to 50°C)
 5 to 95%RH Noncondensing

Intermittent: -40 to 131°F (-40 to 55°C)
 5 to 95%RH Noncondensing

Certifications: RoHS and CE

Specifications subject to change without notice.



Diagnostics

POSSIBLE PROBLEMS: POSSIBLE SOLUTIONS:

- General troubleshooting
- Determine that the input is set up correctly in the controller's and building automation software.
 - Check wiring for proper termination
 - Check for corrosion at either the controller or the sensor. Clean off the corrosion, re-strip the interconnecting wire and reapply the connection. In extreme cases, replace the controller, interconnecting wire and/or sensor.
 - Check that the wiring is good between the CO unit and the controller. To do this, label the wires at both ends and then disconnect the wires from the controller and the sensor. With the interconnecting wires separated at both ends, use a multimeter to measure the resistance from wire-to-wire. The meter should read either greater than 10 Meg-ohms, open or OL depending on the style of meter. Now connect the wires together at one end and measure the resistance from wire-to-wire with a multimeter at the other end. The meter should read less than 10 ohms for 22 gauge or larger wire and runs of 250 feet or less) The resistance may be slightly higher for smaller wires or longer runs. If either test fails, replace the wire.
- Unit does not operate
- Cycle power.
 - Disconnect the power wires from the power source and check for proper power at the source as specified in the Termination section on page 2. If the voltage is outside the specifications, troubleshoot the power source. Reconnect power wires to the source when finished
 - Disconnect the power wires at the sensor and verify that the power is the same at the sensor as at the power source. If the voltage is different at the sensor from the source, troubleshoot the wiring. Reconnect power wires to sensor when finished.
 - Measure the power at the sensor with the power wires connected to the power source and to the sensor. If the voltage is outside the limits specified on page 2, but within the limits when the wires are disconnected to the sensor, call your BAPI representative.
- BACnet or RS-485 issues
- Typical BACnet and RS-485 troubleshooting steps include the following:
 - Confirm polarity on + and -, try swapping wires if not sure of the polarity.
 - Confirm all devices share a common RS-485 reference (ground).
 - Confirm settings such as baud rate, parity, etc. match on all devices connected to the network.
 - Confirm that the sensor's address, device instance, and device name are unique on the network, i.e. no other devices use the same values.
 - Confirm that the max master setting on all devices is higher or equal to the highest address on the network.

Specifications subject to change without notice.