

Small Yet Powerful

- Minimum 35 in-lb torque in a compact package. For damper areas up to 8 sq-ft*.



Quiet Plus® VAV terminal unit by Warren Technology

Areas of Application

VAV Units and Small Zone Dampers

Rack and pinion type actuator replaced by direct coupled LM.

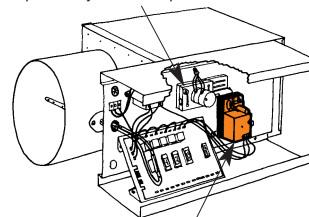

Replacement LM24 compatible with existing control system.

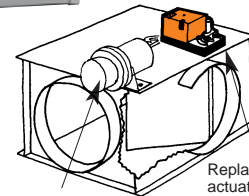

Existing pneumatic actuator requires linkage. Replacement Belimo actuator (LM type) direct couples to VAV By-Pass damper shaft.



Actuators in bold have BDCM

LM Series - at a glance

	LM24-3 US (p. 158) (H)	LM24-3-T US (p.158) (H)	LM24-S US (p.162)	LM24-10P US (p.162)	LM24-3-5P0-T US (p.158) (H)	LM24-SR US (p. 160) (H)	LM24-SR-T US (p. 160) (H)	LMC24 US (p.164)	LMC24-SR US (p.164)	LMC24-SR-T US (p.164)	LM24-MFT US (p.166)
Torque:	35 in-lb	●	●	●	●	●	●	●	●	●	●
Power supply :	24 VAC/DC	●	●	●	●	●	●	●	●	●	●
Brushless DC motor:		●	●			●	●				
Control signal: on-off		●	●	●	●			●			
floating point		●	●	●	●						
proportional 2 to 10 VDC						●	●		●	●	
Multi-function**											●
Feedback signal: 2 to 10 VDC						●			●		
VDC variable**											●
10kΩ feedback potentiometer				●							
5kΩ feedback potentiometer					●						
Run time: 95 sec							●	●			
80 to 110 sec for 0 to 35 in-lb			●	●	●						
25 to 35 sec for 0 to 18 in-lb							●	●	●		
Adj. 75 to 300 sec.***											●
Left/Right rotation switch	●		●	●		●	●	●	●	●	●
Angle of rotation limiting (mechanical)	●	●	●	●	●	●	●	●	●	●	●
Angle of rotation limiting (electronic)						●		●			
Plenum rated cable, 18 GA	●		●	●		●		●	●		●
Screw terminal strip		●			●		●			●	
Manual override push-button	●	●	●	●	●	●	●	●	●	●	●
Built-in auxiliary switch			●								
Installation instructions(p. 168–170)	General wiring(p. 169)										
Start-up and checkout(p. 171)											

*Based on 4 in-lb/ft² damper torque loading. Parallel blade. No edge seals. **Default 2 to 10 VDC ***Default 150 seconds

(H) Halomo Brushless DC Motor Technology

A CLOSER LOOK...



- Brushless DC Motor for added accuracy and controllability.
- Cut labor costs with simple direct coupling.
- Check damper position from a distance with clear position indication.
- Don't worry about actuator burn-out. Belimo is overload-proof throughout rotation.
- Enjoy added flexibility with easy mechanical stops to adjust angle of rotation. (LM24-SR US has electronic rotation limiting.)
- Consistent running time independent of load.
- Easily accessible manual override push-button helps you pre-tension damper blades.
- Need to change control direction? Do it easily with a simple switch.
- 3 ft. plenum rated cable eases installation (external terminal strip also available)



Bulk Packaging Offers Big Value for Large Jobs, Stocking Orders.



The Belimo Difference

- **Customer Commitment.**
Extensive product range. Application assistance. Same-day shipments. Free technical support. Five year warranty.
- **Low Installation and Life-Cycle Cost.**
Easy installation. Accuracy and repeatability. Low power consumption. No maintenance.
- **Long Service Life.**
Components tested before assembly. Every product tested before shipment. 30+ years direct coupled actuator design.

LM24-3 (-T) US / LM24-3 (-5P0) (-T) US



On-off/ floating point control, non-spring return, direct coupled, 24 V



Torque min. 35 in-lb, for control of damper surfaces up to 8 sq ft.

LM24-3 US
LM24-3-T US
LM24-3-5P0-T US



Application

For on-off and floating point control of dampers in HVAC systems. Actuator sizing should be done in accordance with the damper manufacturer's specifications. The actuator mounts directly to the damper operating shaft with a universal V-bolt clamp assembly.

Operation

The actuator is not provided with and does not require any limit switches, but is electronically protected against overload. The angle of rotation is mechanically limited to 95°. When reaching the damper or actuator end position, the actuator automatically stops. The gears can be manually disengaged with a button on the actuator cover. The position of the actuator is indicated by a visual pointer. The anti-rotation strap supplied with the actuator will prevent lateral movement.

The LM24-3 US, LM24-3-T US and LM24-3-5P0-T US actuators use a Brushless DC motor, which is controlled by an Application Specific Integrated Circuit (ASIC). The ASIC monitors and controls the actuator's rotation and provides a digital rotation sensing (DRS) function to prevent damage to the actuator in a stall condition.

Technical Data	LM24... on-off/floating point
Power supply	24 VAC ± 20% 50/60 Hz 24 VDC ± 10%
Power consumption	running: 2 W; holding: 1W
Transformer sizing	3 VA (Class 2 power source)
Electrical connection*	3 ft, 18 GA, UL CL2P plenum cable
Control	On-off/Floating point
Overload protection	Electronic throughout 0 to 95° rotation
Input impedance	600Ω
Angle of rotation	max 95°, adjust. with mechanical stops
Torque	min 35 in-lb [4 Nm], Independent of load
Direction of rotation	reversible with switch CW/CCW (not on "-T" models)
Position indication	clip-on indicator (not on "-T" models)
Running time	95 seconds
Manual override	external push button
Humidity	5 to 95% RH, non-condensing
Ambient temperature	-22°F to +122°F [-30°C to +50°C]
Storage temperature	-40°F to +176°F [-40°C to +80°C]
Housing type	NEMA type 2 (-T models NEMA 1)
Housing material rating	UL94-5V
Noise level	less than 35 dB (A)
Servicing	maintenance free
Agency listings	UL873 listed, CSA 22.2 No. 24 certified, CE
Quality standard	ISO 9001
Weight	1.2 lbs [0.55 kg]

LM24-3-T.1 US

Electrical connection	Screw terminal (for 26 to 14 GA wire)
Housing	NEMA type 1
Direction of rotation	Reverse wires terminals 2 and 3

LM24-3-5P0-T US

Feedback	5 kΩ, 1W potentiometer
Housing	NEMA type 1
Direction of rotation	Reverse wires terminals 2 and 3

*Standard cable length is 3 ft [1m]. Optional cable lengths of 6 ft [200m] or 10 ft [300m] are available at additional list price.

Accessories

11533	T-type anti-rotation bracket
22065	L-type anti-rotation bracket (included)
ZG-LMSA	Short shaft adaptor
Tool-06	8mm and 10 mm wrench

Dimensions [All numbers in brackets are in millimeters.]

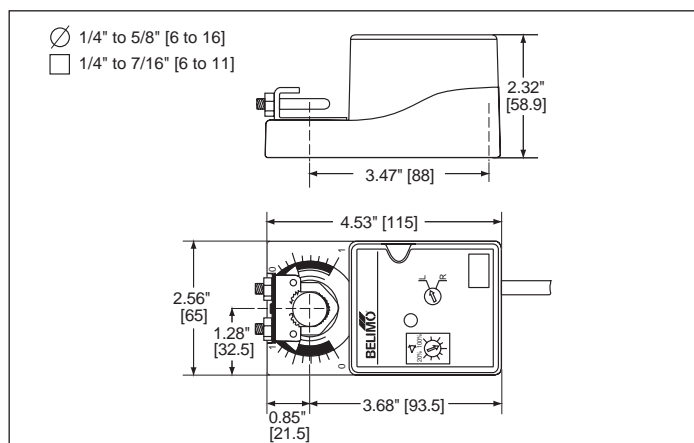

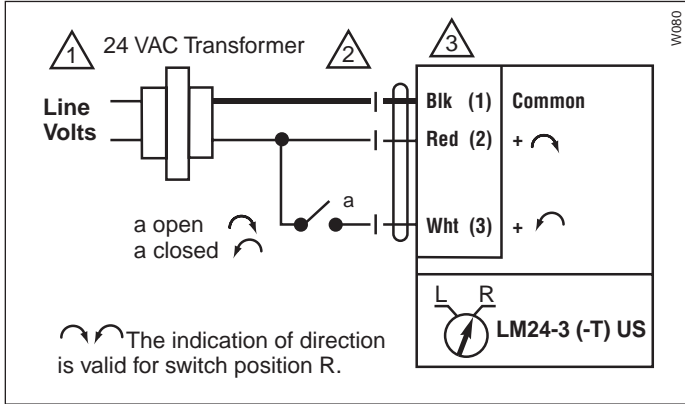

On-off control

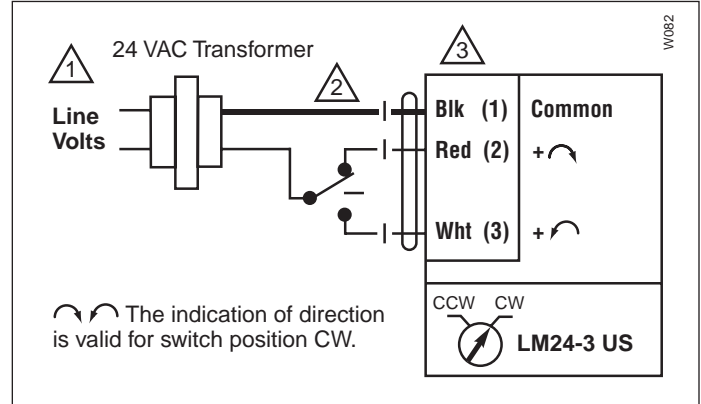

Floating point or on-off control

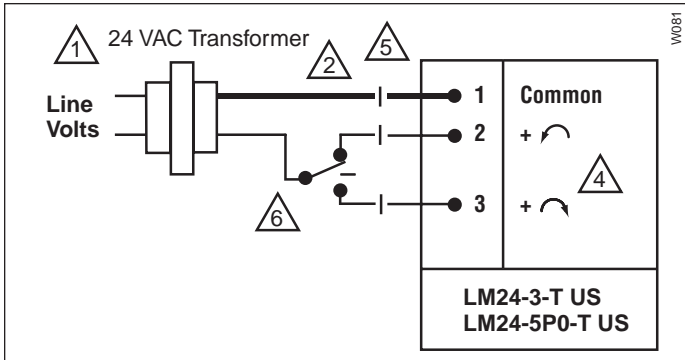

Floating point or on-off control of LM24-3-T US and LM24-3-5P0-T US

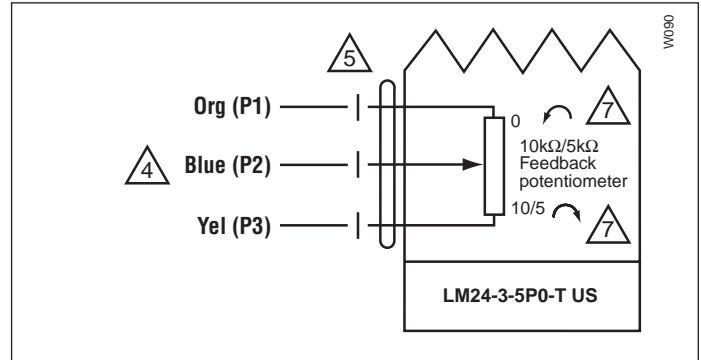

Feedback potentiometer wiring for LM24-3-5P0-T US

T-Type bracket

These are included in the single-actuator packages and are available at no extra cost in the bulk packages upon request.

Part # 11533 (1 piece)

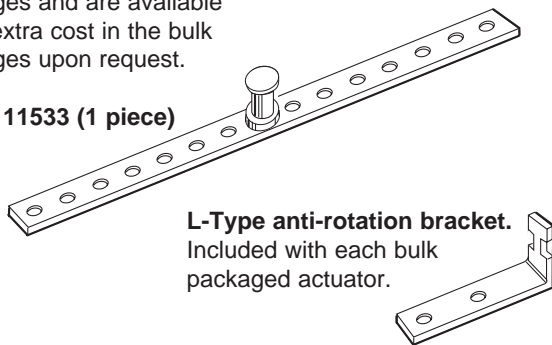

L-Type anti-rotation bracket.
Included with each bulk packaged actuator.

Part #: 22065 (1 piece)
12502-00002
(includes 22065: 16 pieces)
shipped with bulk pack option.

Bulk packaging

Bulk Pack No.	Actuator Type	Quantity/Pack
LM24-3.1 US	LM24-3 US	32
LM24-3-T.1 US	LM24-3-T US	48
LM24-3-5P0-T.1 US	LM24-3-5P0-T US	48

To have better control of job site inventory and reduce the environmental impact of unnecessary packing material.

Notes

- 1 Provide overload protection and disconnect as required.
- 2 Actuators may also be powered by 24 VDC.
- 3 Actuators are provided with color coded wires. Wire numbers are provided for reference.
- 4 For position indication, the LM24-3-5P0-T US is provided with a 5 kΩ feedback potentiometer.
- 5 The LM24-3-T US and LM24-3-5P0-T US are provided with a numbered screw terminal strip instead of cable.
- 6 Switch wires 2 and 3 to change rotation direction of LM24-3-T US and LM24-3-5P0-T US (does not have CW/CCW external switch).
- 7 Value based on resistance between (P1) and (P2). ↻ indicates direction of rotation of actuator.

LM24... on-off - Typical Specification:

Control damper actuators shall be electronic direct coupled type which require no crank arm and linkage. Actuators shall be UL and CSA listed, have a 5 year warranty, and be manufactured under ISO 9001 International Quality Control Standards. Actuators shall have reversing switch and manual override on the cover, and be protected from overload at all angles of rotation. If required, actuator will be provided with screw terminal strip for electrical connections (LM24-3-T US and LM24-3-5P0-T US). If required, one adjustable SPDT auxiliary switch shall be provided (LM24-S US). If required, actuators shall be provided with a built-in 5 kΩ feedback potentiometer (LM24-3-5P0-T US) for use in modulating (floating point) applications. Actuators shall be as manufactured by Belimo.

LM24-SR (-T) US

Proportional control, non-spring return, direct coupled, 24 V, for 2 to 10 VDC and 4 to 20 mA control signal



Torque min. 35 in-lb, for control of damper surfaces up to 8 sq ft.

LM24-SR US
LM24-SR-T US



Application

For proportional modulation of dampers in HVAC systems. Actuator sizing should be done in accordance with the damper manufacturer's specifications. The actuator mounts directly to the damper operating shaft with a universal V-bolt clamp assembly. The actuator operates in response to a 2 to 10 VDC or, with the addition of a 500 Ω resistor, a 4 to 20 mA input signal from an electronic controller or positioner. A 2 to 10 VDC feedback signal is provided for position indication or master slave applications. (Not available on "-T" versions) The LM24-SR US provides an electronic angle of rotation adjustment to limit the actuators rotation 20% to 100% while still using the full input signal and feedback control range. (Not available on LM24-SR-T US)

Operation

The anti-rotation strap supplied with the actuator will prevent lateral movement of the actuator. The damper actuator is not provided with and does not require any limit switches, but is protected electronically against overload. The angle of rotation is mechanically limited to 95°. When reaching the damper or actuator end position, the actuator automatically stops. The gears can be manually disengaged by pressing a button on the actuator cover. The position of the actuator is indicated by a visual pointer.

The LM24-SR US and LM24-SR-T US actuators use a Brushless DC motor, which is controlled by an Application Specific Integrated Circuit (ASIC). The ASIC monitors and controls the actuator's rotation and provides a digital rotation sensing (DRS) function to prevent damage to the actuator in a stall condition.

Accessories

- 11533 T-type anti-rotation bracket
- 22065 L-type anti-rotation bracket (included)
- ZG-LMSA Short shaft adaptor
- Tool-06 8mm and 10 mm wrench
- ZG-R01 500Ω resistor for 4 to 20 mA

Dimensions [All numbers in brackets are in millimeters.]

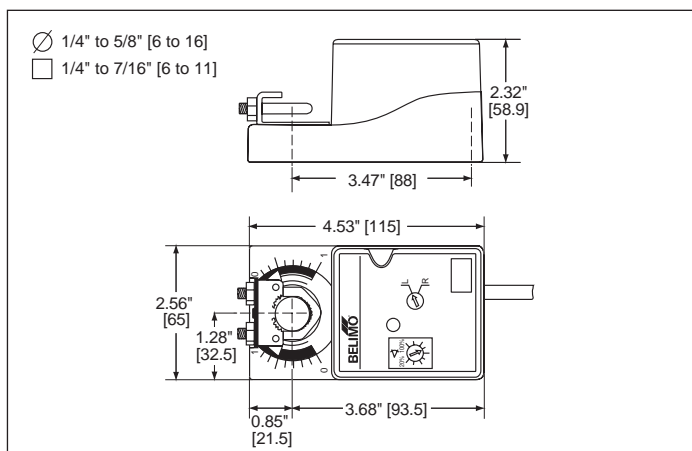

Technical Data	LM24-SR US
Power supply	24 VAC ± 20% 50/60 Hz 24 VDC ± 10%
Power consumption	running: 2 W; holding: 1 W
Transformer sizing	4 VA (Class 2 power source)
Electrical connection*	LM24-SR US: 3 ft, 18 GA, UL CL2P plenum cable
Overload protection	Electronic throughout 0 to 95° rotation
Operating range Y	2 to 10 VDC, 4 to 20 mA
Input impedance	100 kΩ (0.1 mA), 500Ω
Feedback output 'U'	2 to 10 VDC (max. 0.7 mA) (not available on LM24-SR-T US)
Angle of rotation	max 95°, electronically adjustable 20 to 100% on LM24-SR US
Torque	min 35 in-lb, Independent of load
Direction of rotation	reversible with switch CW/CCW CW = with an increase in voltage CCW = with an increase in voltage
Position indication	clip-on indicator (not on "-T" models)
Running time	95 seconds
Manual override	external push button
Humidity	5 to 95% RH, non-condensing
Ambient temperature	-22°F to +122°F [-30°C to +50°C]
Storage temperature	-40°F to +176°F [-40°C to +80°C]
Housing type	NEMA type 2 (-T models Nema type1)
Housing material rating	UL 94-5V
Noise level	less than 35 dB (A)
Servicing	maintenance free
Agency listings	UL 873 listed, CSA 22..2 No. 24 certified, CE
Quality standard	ISO 9001
Weight	1.2 lbs [0.55 kg]

LM24-SR-T.1 US

Electrical connection	Screw terminals (for 26 to 14 GA wire)
Angle of rotation	max 95°, adjust. with mechanical stops
Housing	NEMA type 1
Feedback	No feedback with the LM24-SR-T US

*Standard cable length is 3 ft [1m]. Optional cable lengths of 6 ft [200m] or 10 ft [300m] are available at additional list price.

Proportional control, non-spring return, direct coupled, 24 V, for 2 to 10 VDC and 4 to 20 mA control signal

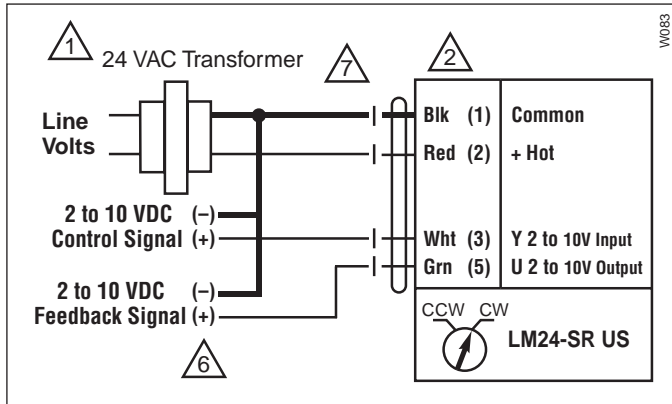

2 to 10 VDC control of LM24-SR US

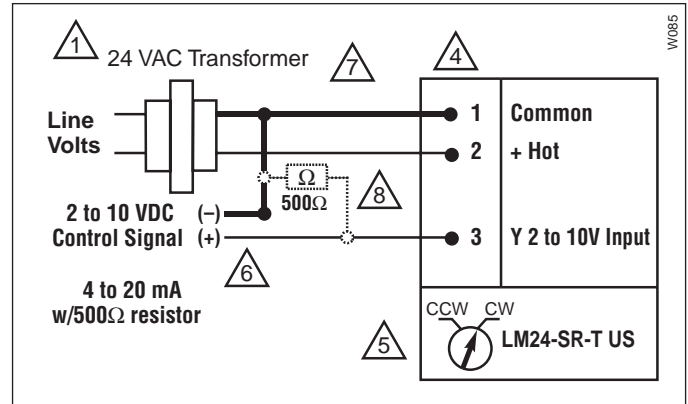

2 to 10 VDC and 4 to 20 mA control of LM24-SR-T US

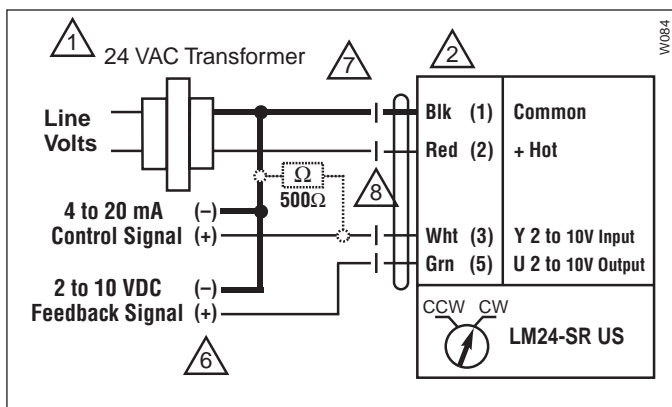

4 to 20 mA control of LM24-SR US with 2 to 10 VDC feedback output

Notes

- 1 Provide overload protection and disconnect as required.
- 2 Actuators are provided with color coded wires. Wire numbers are provided for reference.
- 4 The LM24-SR-T US is provided a screw terminal instead of cable.
- 5 The LM24-SR-T US does not have feedback.
- 6 Connect actuator common (Wire 1) to Negative (-) leg of control circuits only.
- 7 Actuators may also be powered by 24 VDC.
- 8 A 500Ω resistor (ZG-R01) must be added for 4 to 20 mA control.

T-Type bracket

These are included in the single-actuator packages and are available at no extra cost in the bulk packages upon request.

Part # 11533 (1 piece)

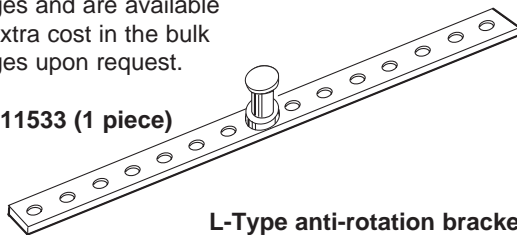

L-Type anti-rotation bracket.

Included with each bulk packaged actuator.

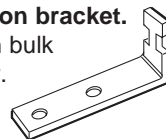

Part #: 22065 (1 piece)
12502-00002

(includes 22065: 16 pieces)
shipped with bulk pack option.

Bulk packaging LM24-SR US and LM24-SR-T US

Bulk Pack No.	Actuator Type	Quantity/Pack
LM24-SR .1 US	LM24-SR US	32
LM24-SR-T.1 US	LM24-SR-T US	48

To have better control of job site inventory and reduce the environmental impact of unnecessary packing material.

LM24-SR (-T) US - Typical Specification:

Control damper actuators shall be electronic direct coupled type which require no crank arm and linkage. Actuators shall be UL and CSA listed, have a 5 year warranty, and be manufactured under ISO 9001 International Quality Control Standards. Actuators shall have Brushless DC motor. Actuators shall have reversing switch and gear disengagement button on the cover, and be electronically protected from overload at all angles of rotation. Actuators shall respond to 2 to 10VDC output relative to position regardless of the amount of damper rotation. A 2 to 10 VDC feedback signal shall be provided for position indication or master-slave applications. Actuators shall be as manufactured by Belimo.

An electronic angle of rotation adjustment shall be provided to reduce the actuators rotation from 100 to 20% while still using the full input signal and feedback control range. (LM24-SR US) If required, actuator will be provided with screw terminal strip for electrical connections (LM24-SR-T US).

LM24-S US, LM24-10P US

On-off control, non-spring return, direct coupled, 24 V



LM24-S US



Torque min. 35 in-lb, for control of damper surfaces up to 8 sq ft.

LM24-S US
LM24-10P US



Application

For on-off control of dampers in HVAC systems. Actuator sizing should be done in accordance with the damper manufacturer's specifications. The actuator mounts directly to the damper operating shaft with a universal V-bolt clamp assembly.

Operation

The actuator is not provided with and does not require any limit switches, but is electronically protected against overload. The angle of rotation is mechanically limited to 95°. When reaching the damper or actuator end position, the actuator automatically stops. The gears can be manually disengaged with a button on the actuator cover. The position of the actuator is indicated by a visual pointer. The anti-rotation strap supplied with the actuator will prevent lateral movement.

Accessories

LM-P	T-type anti-rotation bracket
ZG-LMSA	Short shaft adaptor
Tool-06	8mm and 10 mm wrench

Technical Data	LM24-S US
Power supply	24 VAC \pm 20% 50/60 Hz 24 VDC \pm 10%
Power consumption	running: 2 W; holding: 1 W
Transformer sizing	3 VA (Class 2 power source)
Electrical connection*	3 ft, 18 GA, UL CL2P plenum cable
Control	On-off
Overload protection	Electronic throughout 0 to 95° rotation
Angle of rotation	max 95°, adjust. with mechanical stops
Torque	min 35 in-lb [4 Nm]
Direction of rotation	reversible w/switch L/R (not on "-T" models)
Position indication	clip-on indicator (not on "-T" models)
Auxiliary switch	Adj. 0° to 95°, SPDT 6 A (2.5A) @ 24 VAC
Running time	80 to 110 sec. for 0 to 35 in-lb
Manual override	external push button
Humidity	5 to 95% RH, non-condensing
Ambient temperature	-22°F to +122°F [-30°C to +50°C]
Storage temperature	-40°F to +176°F [-40°C to +80°C]
Housing type	NEMA type 2 (-T models NEMA 1)
Housing material rating	UL94-5V
Noise level	less than 35 dB (A)
Servicing	maintenance free
Agency listings	UL 873 listed, CSA C22.2 No.24 certified, CE
Quality standard	ISO 9001
Weight	1.2 lbs [0.55 kg]

LM24-10P US

Control	On-off/Floating point
Feedback	10 k Ω , 1W potentiometer

Dimensions [All numbers in brackets are in millimeters.]

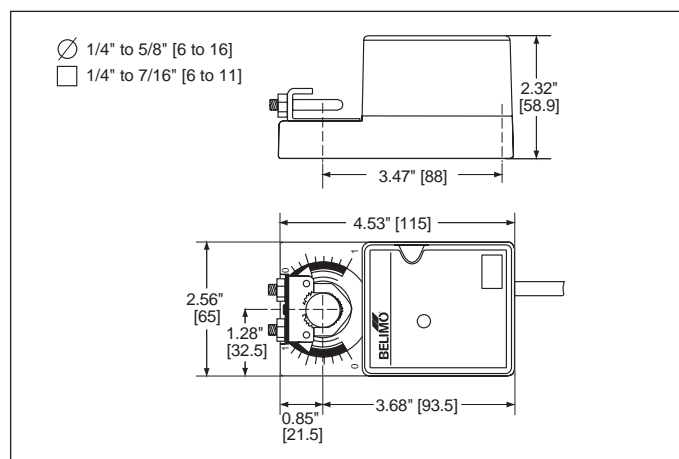

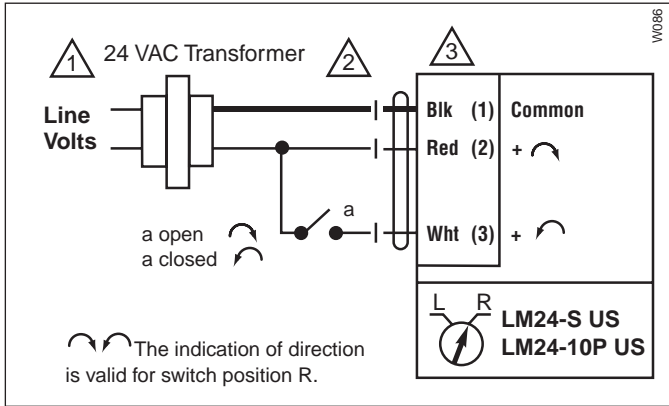

On-off control

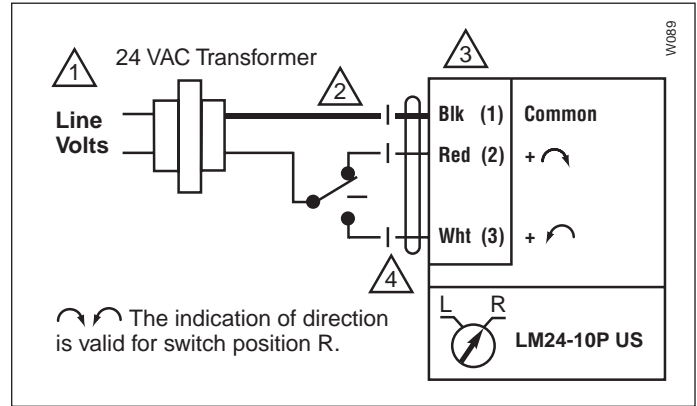

Floating point or on-off control

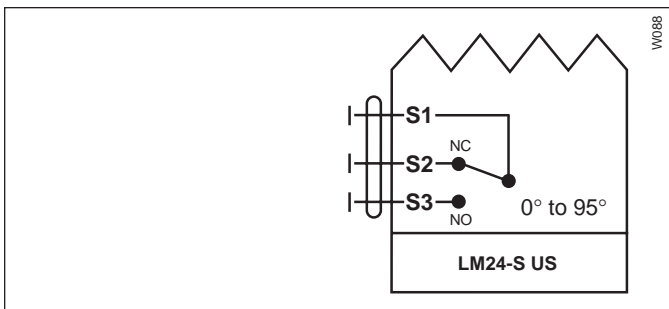

Auxiliary switch wiring for LM24-S US

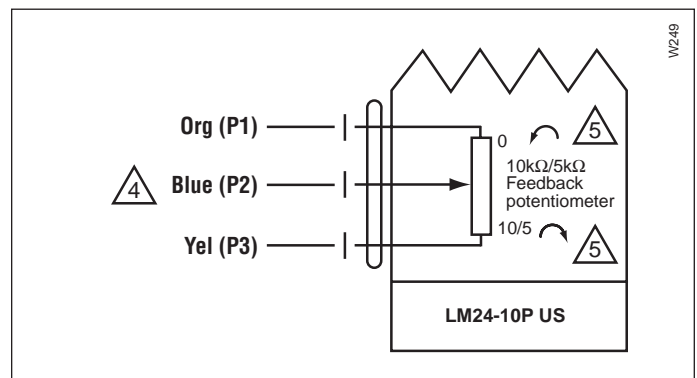

Feedback potentiometer wiring for LM24-10P US

L-Type anti-rotation bracket. Included with each actuator.

Part #: 22065

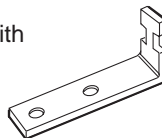

Notes

- 1 Provide overload protection and disconnect as required.
- 2 Actuators may also be powered by 24 VDC.
- 3 Actuators are provided with color coded wires. Wire numbers are provided for reference.
- 4 For position indication, the LM24-10P US is provided with a 10 kΩ feedback potentiometer.
- 5 Value based on resistance between (P1) and (P2). ↻ indicates direction of rotation of actuator.

LM24... on-off - Typical Specification:

Control damper actuators shall be electronic direct coupled type which require no crank arm and linkage. Actuators shall be UL and CSA listed, have a 5 year warranty, and be man-ufactured under ISO 9001 International Quality Control Standards. Actuators shall have reversing switch and manual override on the cover, and be protected from overload at all angles of rotation. If required, one adjustable SPDT auxiliary switch shall be provided (LM24-S US). If required, actuators shall be provided with a built-in 10 kΩ feedback potentiometer (LM24-10P US) for use in modulating (floating point) applications. Actuators shall be as manufactured by Belimo.

LMC24 (-SR) (-T) US



Non-spring return, direct coupled, 24 V, 25 to 35 sec. running time



Torque min. 18 in-lb, for control of damper surfaces up to 4.5 sq ft.

LMC24 US (on/off)
 LMC24-SR US (proportional)
 LMC24-SR-T US (proportional)



Application

For on-off control of dampers in HVAC systems (LMC24 US).
 For proportional modulation of dampers in HVAC systems (LMC24-SR-T US). Actuator sizing should be done in accordance with the damper manufacturer's specifications. The actuator mounts directly to the damper operating shaft with a universal V-bolt clamp assembly.

The LMC24-SR-T US actuator operates in response to a 2 to 10 VDC or, with the addition of a 500 Ω resistor, a 4 to 20 mA input signal from an electronic controller or positioner. A 2 to 10 VDC feedback signal is provided for position indication or master slave applications. The LMC24-SR US provides an electronic angle of rotation adjustment (not available in the LMC24-SR-T US) to limit the actuators rotation 20% to 100% while still using the full input signal and feedback control range.

Operation

The actuator is not provided with and does not require any limit switches, but is electronically protected against overload. The angle of rotation is mechanically limited to 95°. When reaching the damper or actuator end position, the actuator automatically stops. The gears can be manually disengaged with a button on the actuator cover. The position of the actuator is indicated by a visual pointer. The anti-rotation strap supplied with the actuator will prevent lateral movement.

Accessories

LM-P	T-type anti-rotation bracket
IRM-100	Input scaling module (For LMC24-SR-T US only)
ZG-LMSA	Short shaft adaptor
PTA-250	Pulse width modulating interface (For LMC24-SR-T US only)
SGA24	Min. and/or manual positioner in NEMA 4 housing (For LMC24-SR-T US only)
SGF24	Min. and/or manual positioner for flush panel mount (For LMC24-SR-T US only)
Tool-06	8mm and 10 mm wrench
ZAD24	Digital position indication (For LMC24-SR-T US only)
ZG-R01	500Ω resistor for 4 to 20 mA (For LMC24-SR-T US only)

Technical Data	LMC24 (-SR) US...
Power supply	24 VAC ± 20% 50/60 Hz 24 VDC ± 10%
Power consumption	LMC24 US 2.0 W (1 W) LMC24-SR (-T) US 2.5 W (1 W)
Transformer sizing	LMC24 US 3 VA LMC24-SR (-T) US 4 VA
Electrical connection	3 ft, 18 GA, UL CL2P plenum cable
Control	On-off (LMC24 US)
Overload protection	Electronic throughout 0 to 95° rotation
Angle of rotation	max 95°, adjust. with mechanical stops (LMC24 US), electronically adjustable 20 to 100% on LMC24-SR US only
Torque	min 18 in-lb [2 Nm]
Operating range Y	2 to 10 VDC, 4 to 20 mA (LMC24-SR (-T) US)
Input impedance	100 kΩ (0.1 mA), 500Ω (LMC24-SR (-T) US)
Feedback output 'U'	2 to 10 VDC (max. 0.7 mA) (LMC24-SR-T US)
Direction of rotation	reversible with switch CCW/CW (LMC24-SR(-T) US) CW with a decrease in voltage CCW with a decrease in voltage
Position indication	clip-on indicator
Running time	25 to 35 sec. for 0 to 18 in-lb
Manual override	external push button
Humidity	5 to 95% RH, non-condensing
Ambient temperature	-22°F to +122°F [-30°C to +50°C]
Storage temperature	-40°F to +176°F [-40°C to +80°C]
Housing type	NEMA type 2
Housing material rating	UL94-5V
Noise level	less than 35 dB (A)
Servicing	maintenance free
Agency listings	UL 873 listed, CSA C22.2 No.24 certified, CE
Quality standard	ISO 9001
Weight	1.2 lbs [0.55 kg]

LMC24-SR-T US

Electrical connection	Screw terminals (for 26 to 14 GA wire)
Angle of rotation	max 95°, adjust. with mechanical stops
Housing	NEMA type 1
Feedback	No feedback with the LMC24-SR-T US

Note: LMC24(-SR) Actuators **do not** have Brushless DC Motor

Dimensions [All numbers in brackets are in millimeters.]

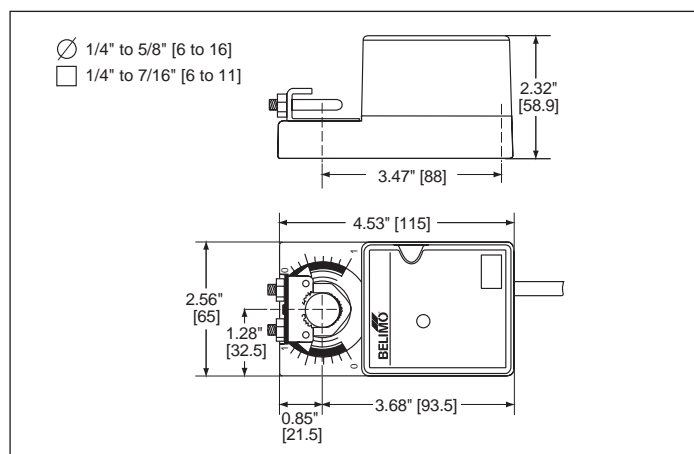

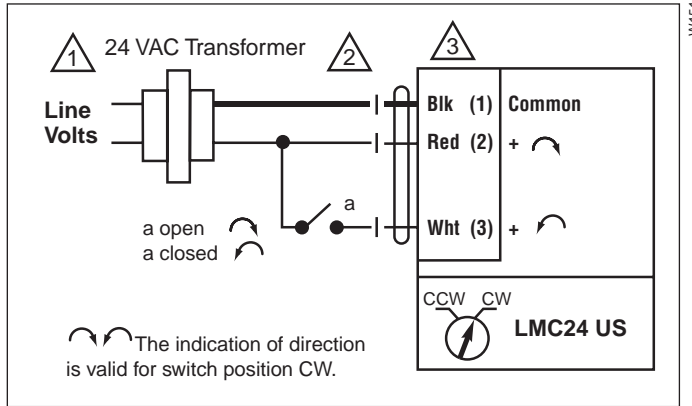

On-off control

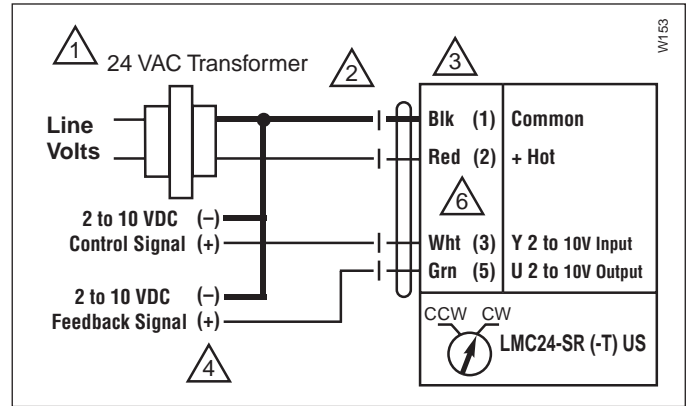

2 to 10 VDC control of LMC24-SR (-T) US

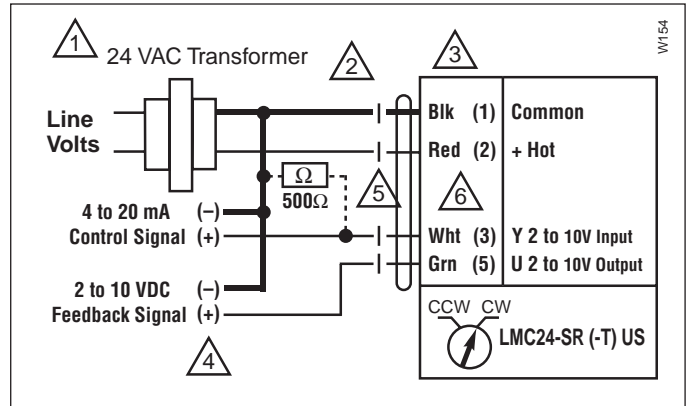

4 to 20 mA control of LMC24-SR (-T) US with 2 to 10 VDC feedback output

Notes

- 1 Provide overload protection and disconnect as required.
- 2 Actuators may also be powered by 24 VDC
- 3 Actuators are provided with color coded wires. Wire numbers are provided for reference.
- 4 Connect actuator common (Wire 1) to Negative (-) leg of control circuits only.
- 5 A 500Ω resistor (ZG-R01) must be added for 4 to 20 mA control.
- 6 LMC24-SR-T US does not have a cable. Numbers shown are terminal numbers.

LMC24... - Typical Specification:

Control damper actuators shall be electronic direct coupled type which require no crank arm and linkage. Actuators shall be UL and CSA listed, have a 5 year warranty, and be manufactured under ISO 9001 International Quality Control Standards. Actuators shall have reversing switch and manual override on the cover, and be protected from overload at all angles of rotation. Actuator shall have a nominal running time of 30 seconds for 95° rotation. Proportional actuators shall respond to 2 to 10VDC output relative to position regardless of the amount of damper rotation. A 2 to 10 VDC feedback signal shall be provided for position indication or master-slave applications. An electronic angle of rotation adjustment (LMC24-SR US only) shall be provided to reduce the actuators rotation from 100 to 20% while still using the full input signal and feedback control range. Actuators shall be as manufactured by Belimo.

L-Type anti-rotation bracket. Included with each actuator.

Part #: 22065

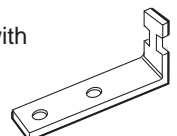

LM24-MFT US



Proportional damper actuator, non-spring return, Multi-Function Technology®



- Torque min. 35 in-lb
- Control 2 to 10 VDC (DEFAULT)
- Feedback 2 to 10 VDC (DEFAULT)

Application

For proportional modulation of dampers in HVAC systems. The LM24-MFT US is a non-spring return type actuator. When supply power is removed the actuator will maintain its last position.

Default/Configuration

The default parameters for 2 to 10 VDC applications of the LM24-MFT US actuator are assigned during manufacturing. If necessary, custom versions of the actuators can be ordered. The parameters noted in the Technical Data table are variable.

These parameters can be changed by three means:

- Pre-set configurations from Belimo
- Custom configurations from Belimo
- Configurations set by the customer using the MFT-Handy® or the MFT-Actuate™ PC software application.

Operation

The LM24-MFT US actuator provides 95° of rotation and is provided with a position indicator. The actuator will synchronize its mechanical stop or the damper or valves mechanical stop and use this point for its zero position during normal control operations.

The actuator uses a brushless DC motor which is controlled by an Application Specific Integrated Circuit (ASIC) and a micro-processor. The microprocessor provides the intelligence to the ASIC to provide a constant rotation rate and to know the actuator's exact position. The ASIC monitors and controls the brushless DC motor's rotation and provides a Digital Rotation Sensing (DRS) function to prevent damage to the actuator in a stall condition. The position feedback signal is generated with out the need for mechanical feedback potentiometers using DRS. The actuator may be stalled anywhere in its normal rotation without the need of mechanical end switches.

The LM24-MFT US is mounted directly to control shafts up to 5/8" diameter by means of its universal clamp and anti-rotation bracket. The actuator provides constant torque to the application with and without power applied to the actuator. The LM24-MFT US actuator is shipped in a Mid position, compression against seats or gaskets for tight shut-off is accomplished manually.

Technical Data	LM24-MFT US
Power supply	24 VAC, ± 20%, 50/60 Hz 24 VDC, ±10%
Power consumption	running: 2 W; holding: 1 W
Transformer sizing	4 VA (Class 2 power source)
Electrical connection	3 ft, 18 GA, UL CL2P plenum cable
Overload protection	electronic throughout 0 to 95° rotation
Operating range Y*	2 to 10 VDC, 4 to 20 mA (w/500 Ω, 1/4 W resistor) ZG-R01
Input impedance	100kΩ for 2 to 10 VDC (0.1 mA) 500Ω for 4 to 20 mA 1500Ω for PWM, Floating point and On-Off control
Feedback output U*	2 to 10 VDC, 0.5 mA max
Torque*	min 35 in-lb (4 Nm)
Direction of rotation*	reversible with switch CW/CCW CW=CW with decrease in signal CCW=CCW with a decrease in signal
Angle of rotation*	0 to 95°, adjust with mechanical stops
Running time*	150 seconds constant
Angle of Rotation Adaptation*	Off (Default)
Override control*	Min. (Min Position) = 0% ZS (Mid. Position) = 50% Max. (Max. Position) = 100%
Manual override	Manual push button
Position indication	clip on indicator
Humidity	5 to 95% RH, non-condensing
Ambient temperature	-22 to +122° F (-30 to +50° C)
Storage temperature	-40 to +176° F (-40 to +80° C)
Housing	NEMA 2, IP54
Housing material	UL 94-5V (flammability rating)
Noise level	less than 35 dB (A)
Agency listings	UL 873 listed, CE, CSA C22.2 No .24 certified
Quality standard	ISO 9001
Servicing	maintenance free
Weight	1.8 lbs. (0.8kg.)

* Variable when configured with MFT options

Dimensions [All numbers in brackets are in millimeters.]

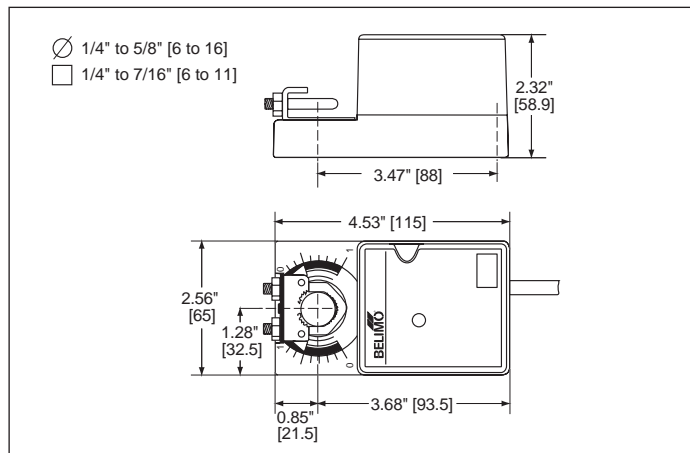

G20492-IG-Subject to change. © Belimo Aircontrols (USA), Inc.

D015

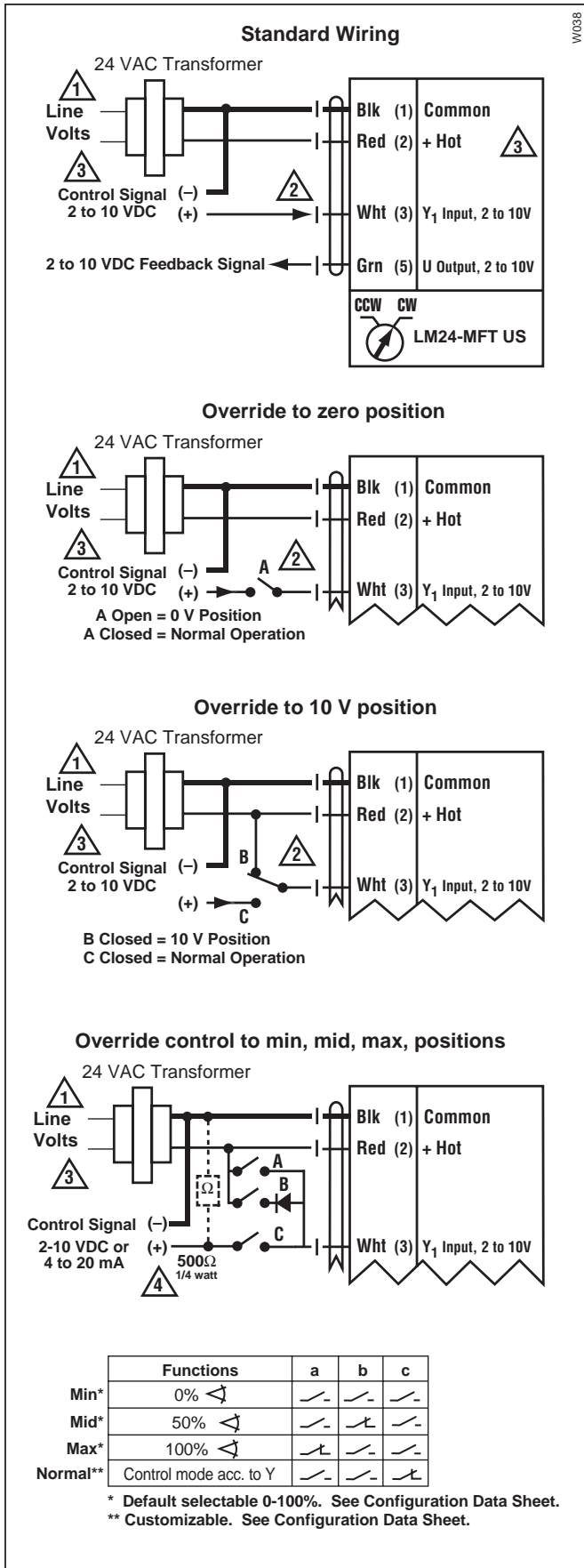

2 to 10 VDC Control Signal

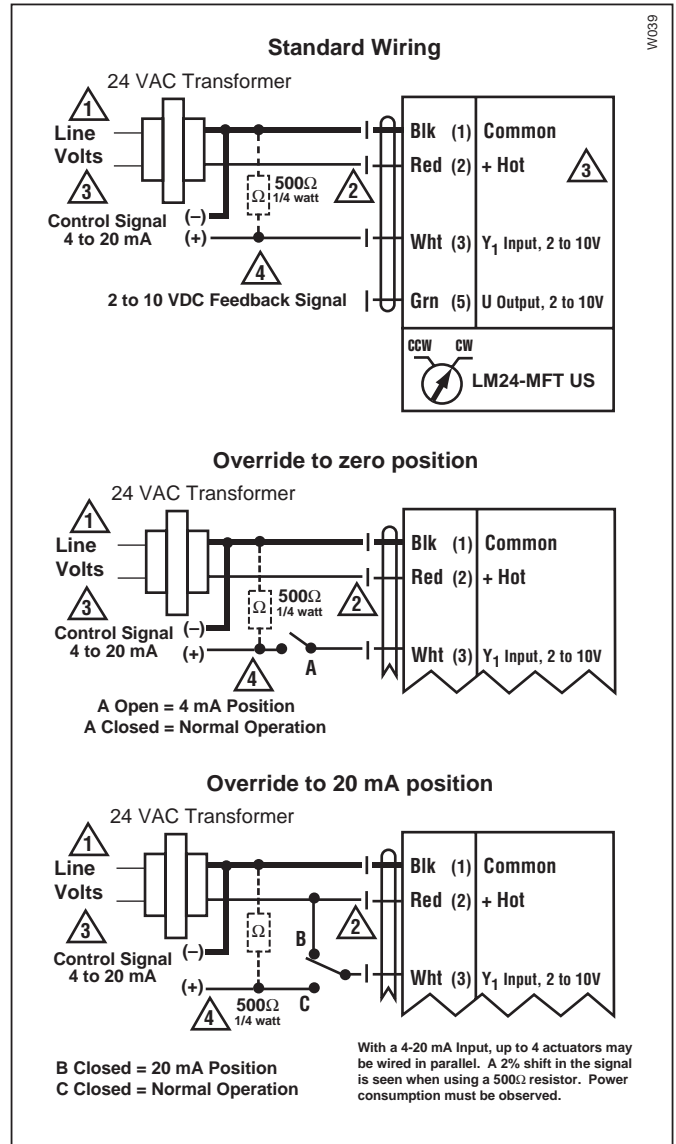

Notes

- 1 Provide overload protection and disconnect as required.
- 2 Actuators may be connected in parallel if not mechanically mounted to the same shaft. Power consumption and input impedance must be observed.
- 3 Actuator may also be powered by 24 VDC.
- 4 ZG-R01 may be used.

Installation Instructions

Quick-mount visual instructions

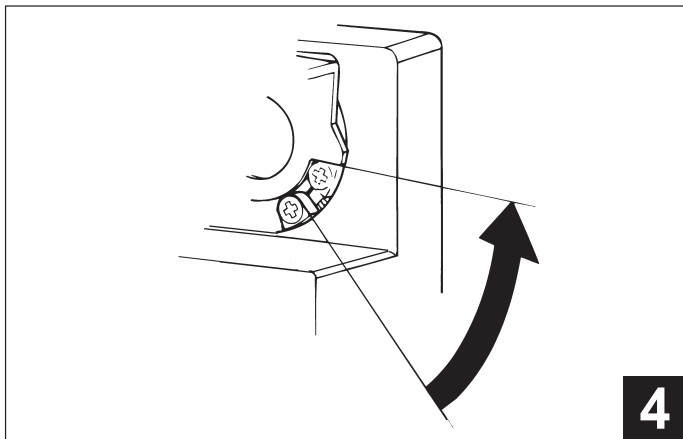
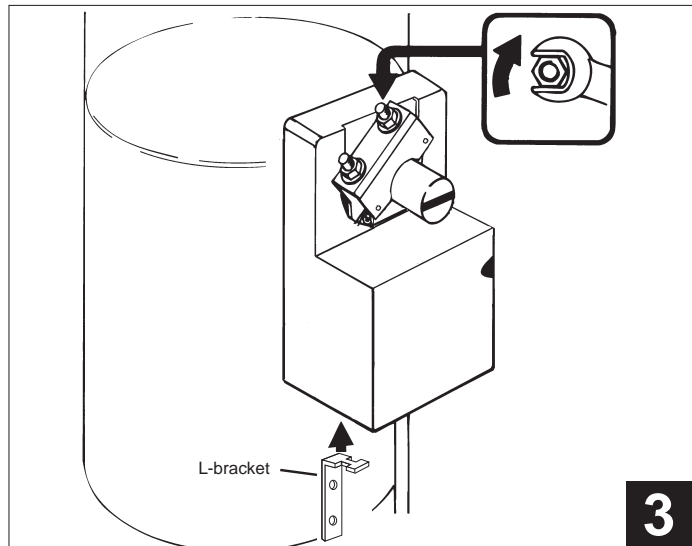
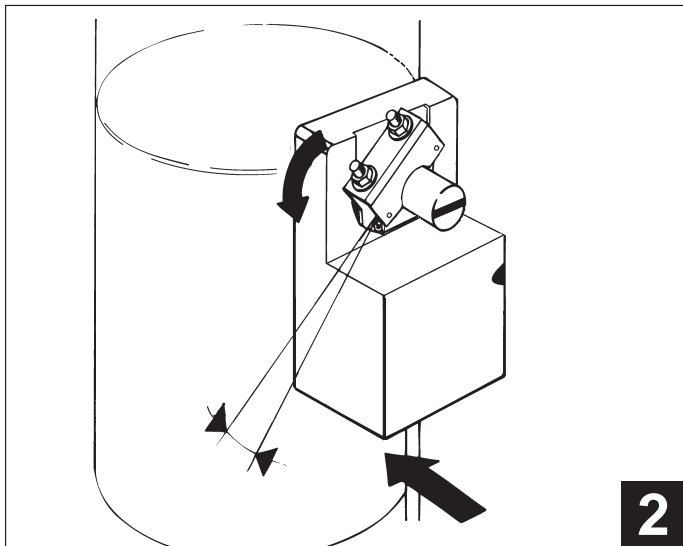
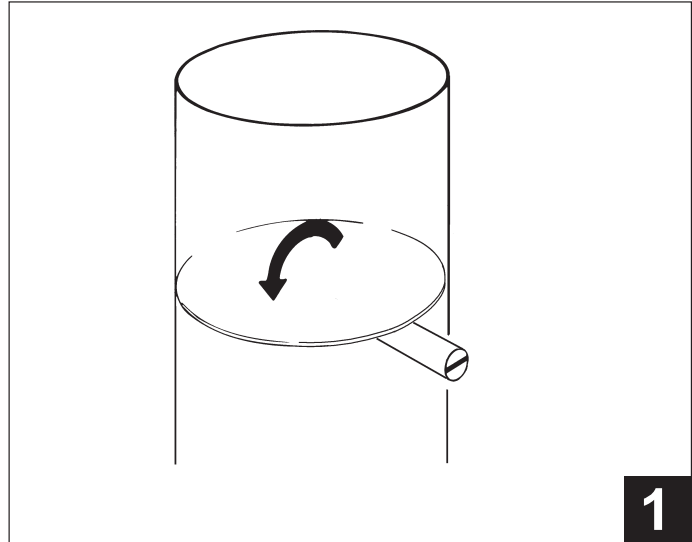
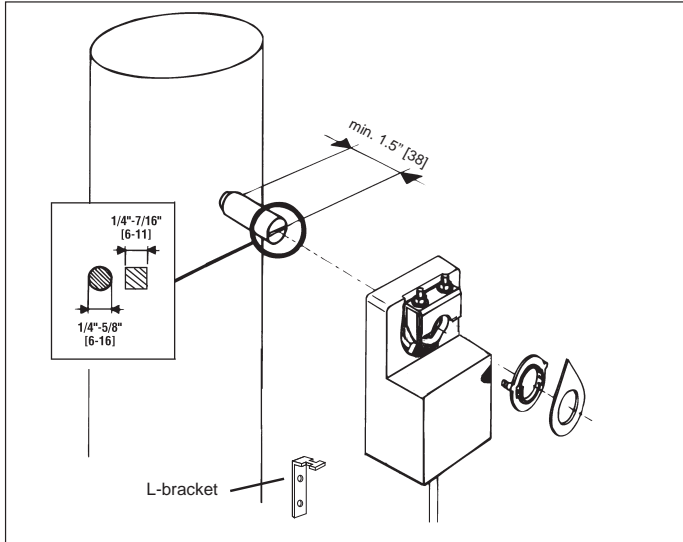

Dimensions (All numbers in brackets are in millimeters.)

1. Turn damper blade to its fully closed position.
2. With manual override button depressed, rotate actuator clamp to about 1/16" - 1/8" between actuator stop and clamp, depending on damper seal design. Slide actuator over shaft and finger-tighten nuts.
3. Slide anti-rotation bracket up under actuator engaging center cut-out on actuator back. Secure bracket with self-tapping screws. Tighten the two nuts on the universal clamp with 8 mm wrench, 3-5 ft-lb torque. (On dampers with edge seals, actuator will compress damper blades when reaching end position for air-tight damper.)
4. Adjust end stops, if required.

Preliminary steps

1. Belimo actuators should be mounted indoors in dry, relatively clean environment free from corrosive fumes. If the actuator is to be mounted outdoors, a protective enclosure must be used to shield the actuator. (See Belimo *Mechanical Accessories* section)
2. For new construction work, **order dampers with extended shafts**. Instruct the installing contractor to allow space for mounting and service of the Belimo actuator on the shaft.
3. The LM Series actuator requires a minimum shaft length of 1.5".
Use the ZG-LMSA for short shaft installations on 1/2" diameter shafts.



WARNING The wiring technician must be trained and experienced with electronic circuits. Disconnect power supply before attempting any wiring connections or changes. Make all connections in accordance with wiring diagrams and follow all applicable local and national codes. Provide disconnect and overload protection as required. Use copper, twisted pair, conductors only.

Always read the controller manufacturer's installation literature carefully before making any connections. Follow all instructions in this literature. If you have any questions, contact the controller manufacturer and/or Belimo.

Transformer(s)

The LM Series actuators require a 24 VAC class 2 transformer and draw a maximum of 4 VA. The actuator enclosure cannot be opened in the field, there are no parts or components to be replaced or repaired.

- EMC directive: 89/336/EEC
- Software class A: Mode of operation type 1
- Low voltage directive: 73/23/EEC

CAUTION: It is good practice to power electronic or digital controllers from a separate power transformer than that used for actuators or other end devices. The power supply design in our actuators and other end devices use half wave rectification. Some controllers use full wave rectification. When these two different types of power supplies are connected to the same power transformer and the DC commons are connected together, a short circuit is created across one of the diodes in the full wave power supply, damaging the controller. Only use a single power transformer to power the controller and actuator if you know the controller power supply uses half wave rectification.

Multiple actuators, one transformer

Multiple actuators may be powered from one transformer provided the following rules are followed:

1. The TOTAL current draw of the actuators (VA rating) is less than or equal to the rating of the transformer.
2. Polarity on the secondary of the transformer is strictly followed. *This means that all No. 1 wires from all actuators are connected to the common leg on the transformer and all No 2 wires from all actuators are connected to the hotleg. Mixing wire No. 1 & 2 on one leg of the transformer will result in erratic operation or failure of the actuator and or controls.*

Multiple actuators, multiple transformers

Multiple actuators positioned by the same control signal may be powered from multiple transformers provided the following rules are followed:

Electrical Operation

Brushless DC Motor Operation

Belimo's Halomo Brushless DC motor spins by reversing the poles of stationary electromagnets housed inside rotation permanent magnets. The electromagnetic poles are switched by a microprocessor and a special ASIC developed by Belimo. Unlike the conventional DC motor, there are no brushes to wear or commutators to foul.

Overload protection

The LM24-3 US and LM24-SR US actuators are electronically protected from overload at all angles of rotation by digital technology in the ASIC. The ASIC circuitry constantly monitors the rotation of the Brushless DC motor inside the actuator and

1. The transformers are properly sized.
2. All No. 1 wires from all actuators are tied together and tied to the negative leg of the control signal. See wiring diagram.

Wire length for LM Series actuators

Keep power wire runs below the limits listed in the Fig. 1. If more than one actuator is powered from the same wire run, divide the allowable wire length by the number of actuators to determine the maximum run to any single actuator.

Maximum wire length:

Wire Size	Max. Feet.	Wire Size	Max. Feet
16 Ga	1225 Ft.	20 Ga	400 Ft
18 Ga	725 Ft.	22 Ga	200 Ft

Fig. 1

Example for LM... US: 3 actuators, 18 Ga wire
 $725 \text{ Ft} \div 3 \text{ Actuators} = 241.6 \text{ Ft. Maximum wire run.}$

Wire Type and Wire Installation Tips

For most installations, 18 or 16 Ga. cable works well with the LM24 type actuators. Use code approved wire nuts, terminal strips or solderless connectors where wires are joined. It is good practice to run control wires unspliced from the actuator to the controller. If splices are unavoidable, make sure the splice can be reached for possible maintenance. Tape and/or wire tie the splice to reduce the possibility of the splice being inadvertently pulled apart.

The Belimo ...MFT proportional actuators have a digital circuit that is designed to ignore unwanted input signals (pickup). In some situations the pickup may be severe enough to cause erratic running of the actuator. For example, a large inductive load (high voltage AC wires, motors, etc.) running near the power or control wiring may cause excessive pickup. To solve this problem, make one or more of the following changes:

1. Run the wire in metallic conduit.
2. Re-route the wiring away from the source of pickup.
3. Use shielded wire (Belden 8760 or equal). **Ground the shield to an earth ground. Do not connect it to the actuator common.**

LM Series Actuators with Terminal Strip

LM...-T actuators feature an external screw terminal strip on the top of the actuator housing (instead of cable). Connections are numbered and a wiring schematic is shown next to the terminal strip. The terminals are designed for 26 to 14 GA wire.

stops the pulsing to the motor when it senses an overload. The motor remains energized and produces full rated torque when overload.

End stop filtering enables the actuator to ignore short controller pulses while at the end position, i.e. pulses that are in the same direction as the end stop, while already at the end position.

Feature Operation

Manual Override

A button on the actuator cover disengages the gear train so a damper shaft can be moved manually. Release the button and the gear train is re-engaged.

Use the manual override to test the installation without power. For tight shut-off the damper should close with 5° of actuator stroke left.

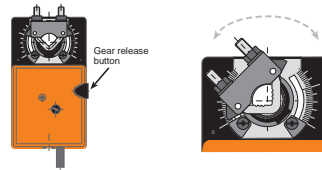

Direction of Rotation Switch (All LM except LM24-3-T US)

LM actuators have a reversing switch on the cover labeled "CW-CCW". Switch position indicates start point. For the LM24-SR (-T) US, with the switch in position "CW", the actuator rotates clockwise with an increase in voltage or current. With the switch in position "CCW", the actuator rotates counterclockwise with an increase in voltage or current.

The LM24-3-T US does not have a switch. They rotate clockwise when power is applied to wire #3, and counterclockwise when power is applied to wire #2.

During checkout, the switch position can be temporarily reversed and the actuator will reverse its direction. This allows

*the technician a fast and easy way to check the actuator operation without having to switch wires or change settings on the thermostat. **When the check-out is complete, make sure the switch is placed back to its original position.***

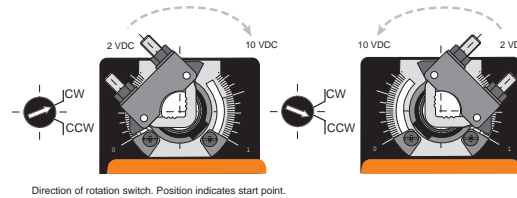

Mechanical Angle of Rotation Limiting (LM Series, On-Off/Floating and LM24-SR-T US)

The adjustable stops are needed when there is no damper stop or if you want the damper to halt rotating before it reaches its stops. The LM actuator can be indefinitely stalled in any position without harm.

1. Loosen the two end stops with a No. 2 Phillips head screwdriver being careful not to unscrew the captive nut under the slot.
2. Move the stops (in 2.5° steps) to the desired position and re-tighten the screws.

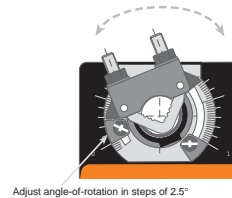

Electronic Angle of Rotation Limiting (LM24-SR US)

With the LM24-SR US proportional actuator, you can adjust the angle of rotation (95°) anywhere between 20% and 100% using an external adjustment. A potentiometer limits rotation while allowing the full control input and feedback range (2 to 10 VDC), providing higher control resolution within the limited angle of rotation.

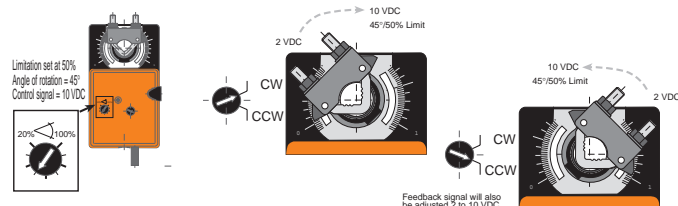

Control Accuracy and Stability

LM24-SR US actuators have built-in brushless DC motors which provide better accuracy and longer service life.

The LM24-SR US actuators are designed with a unique non-symmetrical deadband. The actuator follows an increasing or decreasing control signal with an 80 mV resolution. If the signal changes in the opposite direction, the actuator will not respond until the control signal changes by 175 mV. This allows these actuators to track even the slightest deviation very accurately, yet allowing the actuator to "wait" for a much larger change in control signal due to control signal instability.

LM Actuator responds to a 80 mV signal when not changing direction from stop position.

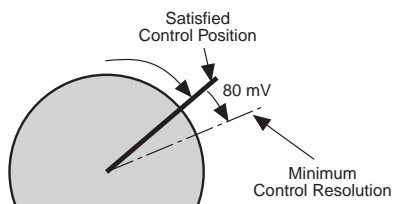

LM Actuator responds to a 175 mV signal when reversing direction from stop position.

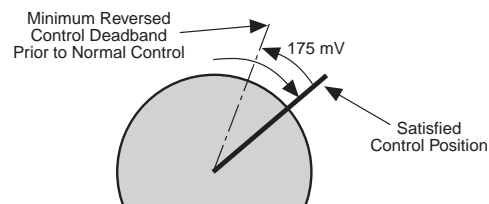

The LM24-MFT US control accuracy and stability can be found in the MFT specifications, page187.

LM24-SR (-T) US and LM24-MFT US + P-100... Electrical check-out procedure

Step	Procedure	Expected Response	Gives Expected Response Go To Step...	Does Not Give Expected Response Go To Step...
1.	Control signal is applied to actuator.	Actuator will move to its "Control Signal" position.	Actuator operates properly Step 8	No response at all Step 2 Operation is reversed Step 3 Does not drive toward "Control Signal Position" Step 4
2.	Check power wiring. Correct any problems. See Note 1.	Power supply rating should be \geq the total power requirement of the actuator(s). Minimum voltage of 19.2 VAC or 21.6 VDC.	Power wiring corrected, actuator begins to drive Step 1	Power wiring corrected, actuator still does not drive Step 4
3.	Turn reversing switch to the correct position.	Actuator will move to its "Control Signal" position.	Actuator operates properly. Step 8	Does not drive toward "Control Signal Position" Step 4
4.	Make sure the control signal positive (+) is connected to Wire No 3 and control signal negative (-) is connected to wire No. 1. Most control problems are caused by reversing these two wires. Verify that the reversing switch is all the way CCW or CW.	Drives to "Control Signal" position	Actuator operates properly. Step 8	Step 5
5.	Check input signal with a digital volt meter (DVM). Make sure the input is within the range of the actuator. For LM24-SR (-T) US this is 0 to 10 VDC or 0 to 20 mA. Note: The input signal must be above the 2 VDC or 4 mA to have the actuator move.	Input voltage or current should be $\pm 1\%$ of what controller's adjustment or programming indicate.	Controller output (actuator input) is correct. Input Polarity Correct. Step 6	Reprogram, adjust repair or replace controller as needed. Step 1
6.	Use the manual override button to move the damper by hand from fully closed to fully open.	Damper will go from fully closed to fully open.	Damper moves properly Step 7	Find cause of damper jam and repair. Step 1
7.	Check damper torque requirement.	Torque requirement is \leq actuator's minimum torque.	Defective Actuator. Replace Actuator - See Note 2	Recalculate actuator requirement and correct installation.
8.	Actuator works properly. Test controller by following controller manufacturer's instructions.			

Note 1 Check that the transformer(s) are sized properly.

- If a common transformer is used, make sure that polarity is observed on the secondary. This means connect all No. 1 wires to one leg of the transformer and all No. 2 wires to the other leg of the transformer.
- If multiple transformers are used with one control signal, make sure all No. 1 wires are tied together and tied to control signal negative (-).
- Controllers and actuators must have separate 24 VAC/VDC power sources.

Note 2 If failure occurs within 5 years from original installation date, notify Belimo and give details of the application.