

AFX24LON - Damper Actuator

Modulating, Spring Return, 24 V, LonWorks®



Technical Data	
Power Supply	24 VAC±20%, 50/60Hz, 24 VDC+20%/-10%
Power Consumption Running	8.5 W
Power Consumption Holding	3.5 W
Transformer Sizing	11 VA (class 2 power source)
Shaft Diameter	1/2" to 1.05" round, centers on 1/2" and 3/4" with insert, 1.05" without insert
Electrical Connection	3 ft, 18 GA appliance cable
Overload Protection	electronic throughout 0° to 95° rotation
Electrical Protection	actuators are double insulated
Operating Range Y	LonWorks®
Feedback Output U	2 to 10 VDC, 0.5 mA max
Angle of Rotation	95° (adjustable with mechanical end stop, 35° to 95°)
Torque	180 in-lbs [20 Nm] minimum
Direction of Rotation (Motor)	reversible with built-in switch
Direction of Rotation (Fail-Safe)	reversible with CW/CCW mounting
Position Indication	visual indicator, 0° to 95° (0° is full spring return position)
Manual Override	5 mm hex crank (3/16" Allen), supplied
Running Time (Motor)	150 sec (default), variable (70 to 220 sec)
Running Time (Fail-Safe)	<20 sec @ -4°F to 122°F [-20°C to 50°C], <60 sec @ -22°F [-30°C]
Override Control	min. position = 0%, mid. Position = 50%, max. position = 100% (Default)
Humidity	max. 95% RH non-condensing
Ambient Temperature Range	-22°F to 122°F [-30°C to 50°C]
Storage Temperature Range	-40°F to 176°F [-40°C to 80°C]
Housing	NEMA 2, IP54, UL enclosure type 2
Housing Material	zinc coated metal and plastic casing
Agency Listings†	cULus acc. to UL60730-1A/-2-14, CAN/CSA E60730-1:02, CE acc. to 2004/108/EC
Noise Level (Motor)	≤40 dB (A) @ 150 sec, run time dependent
Noise Level (Fail-Safe)	<62 dB (A)
Servicing	maintenance free
Quality Standard	ISO 9001
Weight	4.3 lb [1.92 kg]

†Rated Impulse Voltage 800V, Type action 1.AA, Control Pollution Degree 3 - LonWorks and LonMARK® 2007-2009 LonMark International.

Torque min. 180 in-lb, for control of air dampers.

Application

Direct coupled, fail-safe actuators for direct link to LonWorks network. Actuators are easily installed by direct shaft mounting on air dampers in ventilation and air conditioning systems. Actuator can be controlled by any compatible LON system. For modulation of dampers and control valves in HVAC systems. The AFX24LON provides mechanical spring return operation for reliable fail-safe application.

Operation

The AFX24LON actuator provides 95° of rotation and is provided with a graduated position indicator showing 0° to 95°. The actuator will synchronize the 0° mechanical stop or the physical damper or valve mechanical stop and use this point for its zero position during normal control operations. A unique manual override allows the setting of any actuator position within its 95° of rotation with no power applied. This mechanism can be released physically by the use of a crank supplied with the actuator. When power is applied the manual override is released and the actuator drives toward the fail-safe position. The actuator uses a brushless DC motor which is controlled by an Application Specific Integrated Circuit (ASIC) and a microprocessor. The microprocessor provides the intelligence to the ASIC to provide a constant rotation rate and to know the actuator's exact position. The ASIC monitors and controls the brushless DC motor's rotation and provides a Digital Rotation Sensing (DRS) function to prevent damage to the actuator in a stall condition. The position feedback signal is generated without the need for mechanical feedback potentiometers using DRS. The actuator may be stalled anywhere in its normal rotation without the need of mechanical end switches. The AFX24LON is mounted directly to control shafts up to 1.05" diameter by means of its universal clamp and anti-rotation bracket. A crank arm and several mounting brackets are available for damper applications where the actuator cannot be direct coupled to the damper shaft. The spring return system provides minimum specified torque to the application during a power interruption. The AFX24LON actuator is shipped at 5° (5° from full fail-safe) to provide automatic compression against damper gaskets for tight shut-off.

Dimensions (Inches[mm])

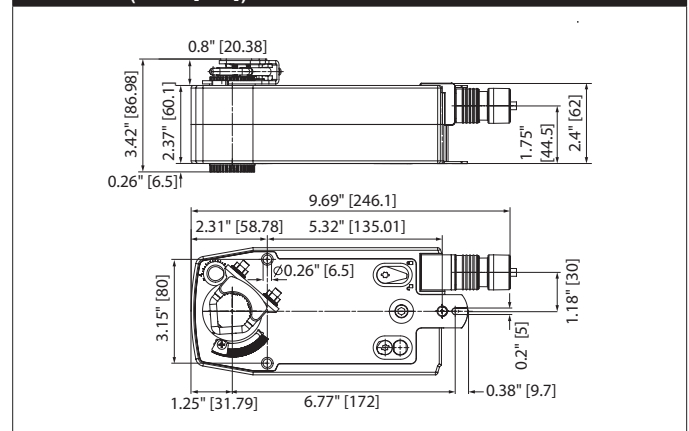

Accessories	
AF-P	Anti-rotation bracket AF/NF.
AV8-25	9.8" shaft extension for 5/16" to 1" diameter shafts.
IND-AFB	AFB(X)/NFB(X) position indicator.
K7-2	Standard AFB(X)/NFB(X) clamp (1/2" to 1.05").
KG10A	Ball joint for 3/8" diameter rod, zinc plated.
KG8	Ball joint for 5/16" diameter rod, 90°, galvanized steel.
KH10	Univ. crankarm, slot 21/64" w, for 9/16" to 1" dia. shafts.
KH12	Univ. crankarm, slot 21/64" w, for 3/4" to 1" dia. shafts.
KH8	Univ. crankarm, slot 21/64" w, for 3/8" to 11/16" dia. shafts.
KH-AFB	AFB(X)/NFB(X) crankarm (with 3/4" dia. shaft pass through).
SH10	Push rod for KG10A ball joint (36" L, 3/8" diameter).
SH8	Push rod for KG6 & KG8 ball joints (36" L, 5/16" diameter).
TOOL-06	8 mm and 10 mm wrench.
Z-AF	Classic AF/NF to AFB(X)/NFB(X) retrofit mounting bracket.
ZG-100	Univ. right angle bracket (17" H x 11-1/8" W x 6" base).
ZG-101	Univ. right angle bracket (13" H x 11" W x 7-7/16" base).
ZG-109	Right angle bracket for ZS-260.
ZG-110	Stand-off bracket for ZS-260.
ZG-118	AFB(X)/NFB(X) U bracket (5-7/8" H x 5-1/2" W x 2-19/32" D).
ZG-120	Jackshaft mounting bracket.
ZG-AFB	AFB(X)/NFB(X) crankarm adaptor kit.
ZG-AFB118	AFB(X)/NFB(X) crankarm adaptor kit.
ZG-DC1	Damper clip for damper blade, 3.5" width.
ZG-DC2	Damper clip for damper blade, 6" width.
ZG-JSA-1	1" diameter jackshaft adaptor (11" L).
ZG-JSA-2	1-5/16" diameter jackshaft adaptor (12" L).
ZG-JSA-3	1.05" diameter jackshaft adaptor (12" L).
ZS-100	Weather shield - galvanneal (13" L x 8" W x 6" D).
ZS-101	Base plate for ZS-100.
ZS-150	Weather shield - PC w/ foam seal (16" L x 8-3/8" W x 4" D).
ZS-260	Explosion proof housing.
ZS-300	NEMA 4X, 304 stainless steel enclosure.
ZS-300-5	NEMA 4X, 316L stainless steel enclosure.
ZS-300-C1	1/2" shaft adaptor, standard with ZS-300(-5).
ZS-300-C2	3/4" shaft adaptor for ZS-300(-5).
ZS-300-C3	1" shaft adaptor for ZS-300(-5).
Z-SF	20 piece Z-AF kit.
MFT-P	Belimo MFT configuration software (hardware not included).
PS-100	Actuator power supply and control simulator.
TF-CC US	Cable conduit connector, 1/2".
ZG-X40	120 to 24 VAC, 40 VA transformer.
ZK1-GEN	Cable for ZTH US to diagnostic/programming socket.
ZK2-GEN	Cable for ZTH US to actuators w/o diagnostics socket.
ZTH US	Handheld programming tool w/ ZK1-GEN, ZK2-GEN, ZK6-GEN.

Typical Specification

Spring return control damper actuators shall be direct coupled type which require no crank arm and linkage and be capable of direct mounting to a jackshaft up to a 1.05" diameter. The actuator must provide modulating damper control in response to a LonWorks controller. The actuators must be designed so that they may be used for either clockwise or counterclockwise fail-safe operation. Actuators shall use a brushless DC motor controlled by a microprocessor and be protected from overload at all angles of rotation. Run time shall be constant, and independent of torque. A 2 to 10 VDC feedback signal shall be provided for position feedback. Actuators shall be cULus listed and have a 5 year warranty, and be manufactured under ISO 9001 International Quality Control Standards. Actuators shall be as manufactured by Belimo.

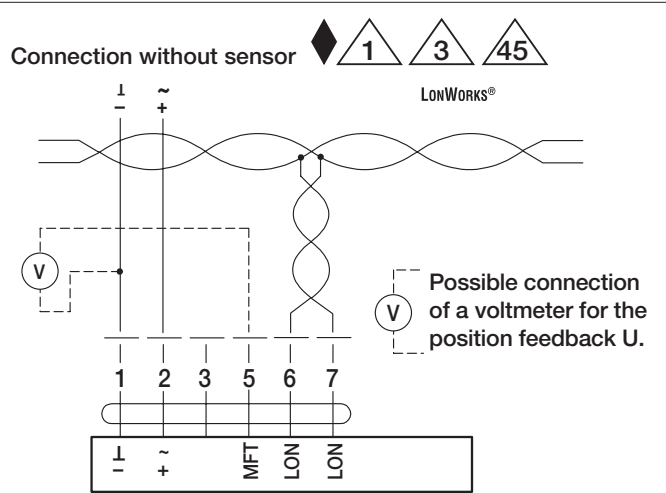

LON - without sensor

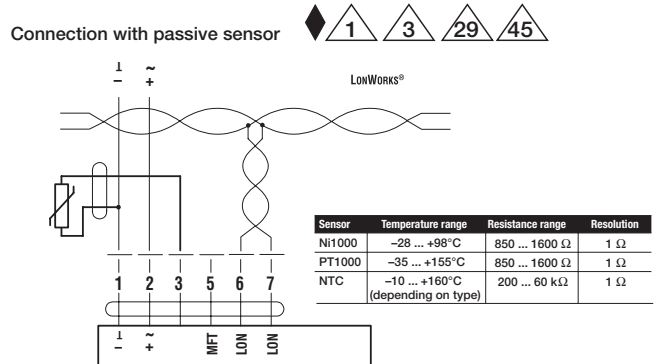

LON - with passive sensor

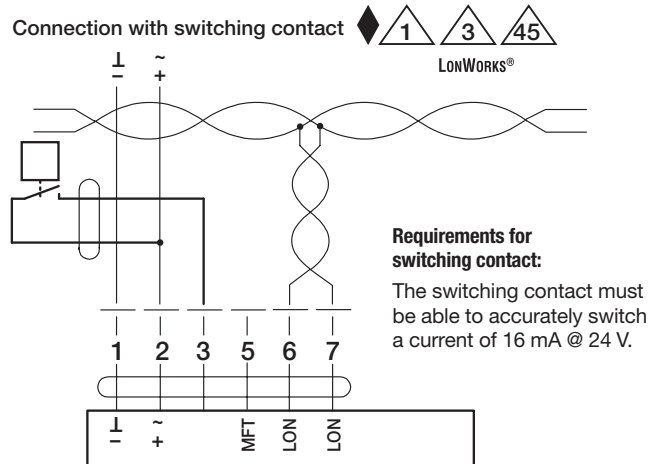

LON - with switching contact

AFX24LON - Damper Actuator

Modulating, Spring Return, 24 V, LonWorks®



Wiring Diagrams

! WARNING! LIVE ELECTRICAL COMPONENTS!
 During installation, testing, servicing and troubleshooting of this product, it may be necessary to work with live electrical components. Have a qualified licensed electrician or other individual who has been properly trained in handling live electrical components perform these tasks. Failure to follow all electrical safety precautions when exposed to live electrical components could result in death or serious injury.

◆ Meets cULus requirements without the need of an electrical ground connection.

1 Provide overload protection and disconnect as required.

3 Actuators may also be powered by 24 VDC.

29 A remote CO2 sensor or DDC controller can change the standard relay opening or closing the sensor circuit. This device can be a relay or a dry bulb/enthalpy limit switch.

45 Actuators may be powered in parallel. Power consumption must be observed.

