

AFXUP-S N4 - Damper Actuator

NEMA 4, On/Off, Spring Return, 24 to 240 VAC



Technical Data	
Power Supply	24...240 VAC, -20% / +10%, 50/60 Hz, 24...125 VDC, ±10%
Power Consumption Running	7 W
Power Consumption Holding	3.5 W
Transformer Sizing	7 VA @ 24 VAC (class 2 power source), 8.5 VA @ 120 VAC, 18 VA @ 240 VAC
Shaft Diameter	1/2" to 1.05" round, centers on 3/4" with insert, 1.05" without insert
Electrical Connection	(2) 3ft [1m], 10ft [3m] or 16ft [5m] 18 GA appliance cables, with 1/2" conduit connectors
Overload Protection	electronic throughout 0° to 95° rotation
Electrical Protection	actuators are double insulated
Angle of Rotation	95°, adjustable with mechanical end stop, 35° to 95°
Torque motor	180 in-lbs [20 Nm]
Direction of Rotation (Motor)	reversible with CW/CCW mounting
Direction of Rotation (Fail-Safe)	reversible with CW/CCW mounting
Position Indication	dial
Manual Override	5 mm hex crank (3/16" Allen), supplied
Running Time (Motor)	<75 sec
Running Time (Fail-Safe)	<20 sec @ -4°F to 122°F [-20°C to 50°C], <60 sec @ -22°F [-30°C]
Ambient Humidity	100% condensing
Ambient Temperature Range	-22...122 °F [-30...50 °C]
Storage Temperature Range	-40...176 °F [-40...80 °C]
Housing	IP66, NEMA 4X, UL Enclosure Type 4
Housing Material	polycarbonate
Agency Listings†	cULus acc. to UL60730-1A/-2-14, CAN/CSA E60730-1:02, CE acc. to 2004/108/EC and 2006/95/EC
Noise Level (Motor)	≤50 dB (A)
Noise Level (Fail-Safe)	<62 dB (A)
Servicing	maintenance free
Quality Standard	ISO 9001
Weight	9.9 lb [4.5 kg]
Auxiliary switch	2 x SPDT, 3A resistive (0.5A inductive) @ 250 VAC, one set at 10°, one adjustable 10° to 90°

†Rated Impulse Voltage 4kV, Type of action 1.AA.B, Control Pollution Degree 4.

Torque min. 180 in-lb, for control of air dampers.

Application

For On/Off, fail-safe control of dampers in HVAC systems. Actuator sizing should be done in accordance with the damper manufacturer's specifications. Control is On/Off from an auxiliary contact or a manual switch. The actuator is mounted directly to a damper shaft up to 1.05" in diameter by means of its universal clamp. Maximum of two AF's can be piggybacked for torque loads of up to 266 in-lbs. Minimum 3/4" diameter shaft and parallel wiring.

Operation

The AF.UP-S N4 series actuators provide true spring return operation for reliable fail-safe application and positive close off on air tight dampers. The spring return system provides constant torque to the damper with, and without, power applied to the actuator. The AF.UP-S N4 series provides 95° of rotation and is provided with a graduated position indicator showing 0° to 95°. The actuator may be stalled anywhere in its normal rotation without the need of mechanical end switches. The AF.UP-S N4 version are provided with two built-in auxiliary switches. These SPDT switches provide safety interfacing or signaling, for example, for fan start-up. The switching function at the fail-safe position is fixed at 10°, the other switch function is adjustable between 10° to 90°. The AF.UP-S N4 actuator is shipped at 5° (5° from full fail-safe) to provide automatic compression against damper gaskets for tight shut-off.

Installation Note: Use suitable flexible metallic conduit or its equivalent with the conduit fitting. Not suitable for plenum applications.

Dimensions (Inches[mm])

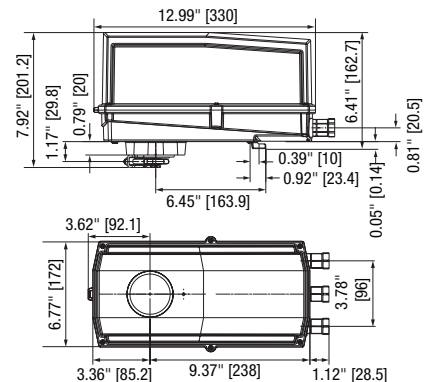

Accessories	
AF-P	Anti-rotation bracket AF/NF.
KG10A	Ball joint for 3/8" diameter rod, zinc plated.
KH10	Univ. crankarm, slot 21/64" w, for 9/16" to 1" dia. shafts.
SH10	Push rod for KG10A ball joint (36" L, 3/8" diameter).
TOOL-06	8 mm and 10 mm wrench.
TOOL-07	13 mm wrench.
ZG-DC1	Damper clip for damper blade, 3.5" width.
ZG-DC2	Damper clip for damper blade, 6" width.
ZG-JSA-1	1" diameter jackshaft adaptor (11" L).
ZG-JSA-2	1-5/16" diameter jackshaft adaptor (12" L).
ZG-JSA-3	1.05" diameter jackshaft adaptor (12" L).
11097-00001	Gasket for cable gland (for NEMA 4 models).
43442-00001	Cable gland (for NEMA 4 models).
P475	Shaft mount, non-Mercury aux. switch for 1/2" dia. shafts.
P475-1	Shaft mount, non-Mercury aux. switch for 1" dia. shafts.
PS-100	Actuator power supply and control simulator.

Typical Specification

On/Off spring return damper actuators shall be direct coupled type which require no crank arm and linkage and be capable of direct mounting to a jackshaft up to a 1.05" diameter. The actuators must be designed so that they may be used for either clockwise or counter clockwise fail-safe operation. Actuators shall be protected from overload at all angles of rotation. If required, two SPDT auxiliary switch shall be provided having the capability of one being adjustable. Actuators with auxiliary switches must be constructed to meet the requirements for Double Insulation so an electrical ground is not required to meet agency listings. Actuators shall be cULus listed and have a 5 year warranty, and be manufactured under ISO 9001 International Quality Control Standards. Actuators shall be as manufactured by Belimo.

Wiring Diagrams

! WARNING! LIVE ELECTRICAL COMPONENTS!
 During installation, testing, servicing and troubleshooting of this product, it may be necessary to work with live electrical components. Have a qualified licensed electrician or other individual who has been properly trained in handling live electrical components perform these tasks. Failure to follow all electrical safety precautions when exposed to live electrical components could result in death or serious injury.

- ◆ Meets cULus requirements without the need of an electrical ground connection.
- ⚡ Apply only AC line voltage or only UL-Class 2 voltage to the terminals of auxiliary switches. Mixed or combined operation of line voltage/safety extra low voltage is not allowed.
- (A) Actuators with appliance cables are numbered.
- (UP) Universal Power Supply (UP) models can be supplied with 24 VAC up to 240 VAC, or 24 VDC up to 125 VDC.
- 1 Provide overload protection and disconnect as required.
- 4 Two built-in auxiliary switches (2x SPDT), for end position indication, interlock control, fan startup, etc.
- 45 Actuators may be powered in parallel. Power consumption must be observed.
- 48 Parallel wiring required for piggy-back applications.

