

B216, 2-Way, Characterized Control Valve

Stainless Steel Ball and Stem

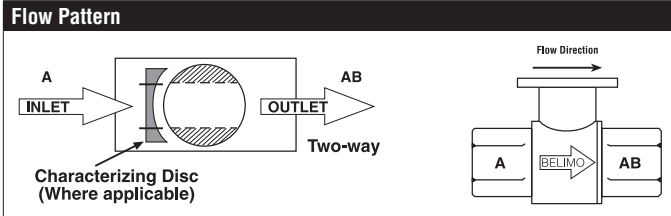

| Technical Data | |
|-----------------------------------|--------------------------------------|
| Service | chilled, hot water, up to 60% glycol |
| Flow Characteristic | equal percentage |
| Controllable Flow Range | 75° |
| Size [mm] | 0.5" [15] |
| End Fitting | NPT female ends |
| Body | forged brass, nickel plated |
| Ball | stainless steel |
| Stem | stainless steel |
| Stem Packing | EPDM (lubricated) |
| Seat | Teflon® PTFE |
| Seat O-ring | EPDM (lubricated) |
| Characterized Disc | No Disc (full flow) |
| Body Pressure Rating [psi] | 600 |
| Media Temperature Range (Water) | 0°F to 250°F [-18°C to 120°C] |
| Max Differential Pressure (Water) | 50 psi (345 kPa) |
| Close-Off Pressure | 200 psi |
| Cv | 16 |
| Weight | 0.7 lb [0.3 kg] |
| Leakage | 0% for A to AB |
| Servicing | maintenance free |



Application

This valve is typically used in air handling units on heating or cooling coils, and fan coil unit heating or cooling coils. Some other common applications include Unit Ventilators, VAV box re-heat coils and bypass loops. This valve is suitable for use in a hydronic system with variable flow.

Suitable Actuators

| | Non-Spring | Spring |
|------|------------|---------|
| B216 | TR, LR, NR | TFR, LF |

Dimensions (Inches [mm])

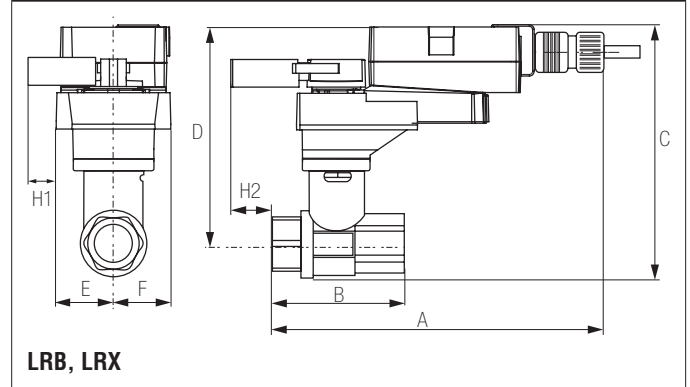

| A | B | C | D | E | F | H1 | H2 |
|------------|------------|-------------|----------|-----------|---|------------|-----------|
| 9.4" [239] | 2.38" [60] | 5.58" [142] | 5" [127] | 1.3" [33] | | 1.18" [30] | 1.1" [28] |

Date created, 10/27/2017 - Subject to change. © Belimo Aircontrols (USA), Inc.

B216, 2-Way, Characterized Control Valve Stainless Steel Ball and Stem

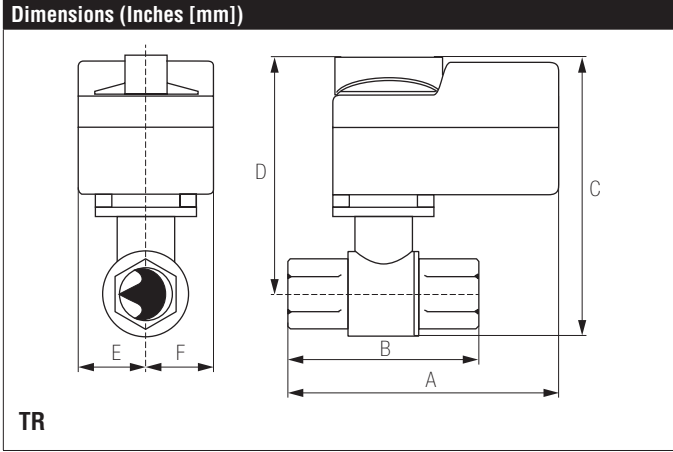

| A | B | C | D | E | F |
|------------|------------|-------------|-------------|------------|---|
| 3.72" [95] | 2.38" [60] | 5.19" [132] | 4.61" [117] | 1.25" [32] | |

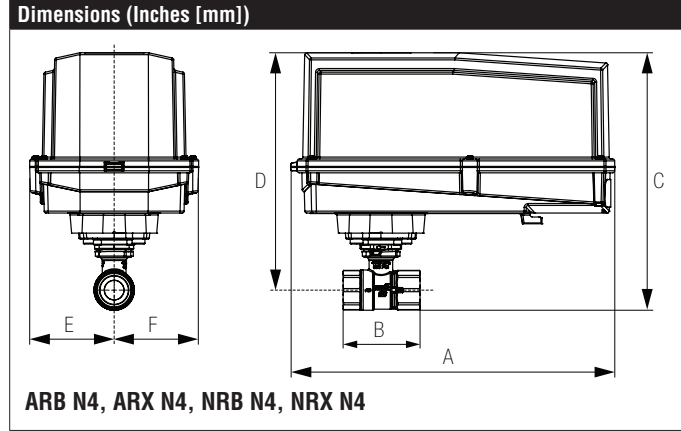

| A | B | C | D | E | F |
|--------------|------------|-------------|-------------|------------|---|
| 11.36" [289] | 2.38" [60] | 7.68" [195] | 7.06" [179] | 3.15" [80] | |

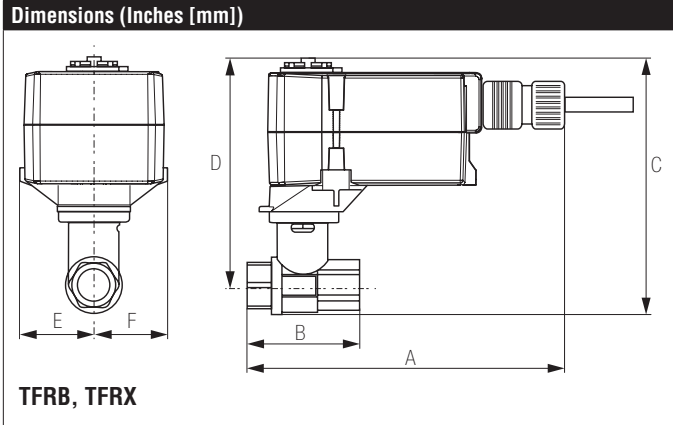

| A | B | C | D | E | F |
|-------------|------------|-------------|-------------|------------|---|
| 6.59" [167] | 2.38" [60] | 5.48" [139] | 4.71" [120] | 1.53" [38] | |

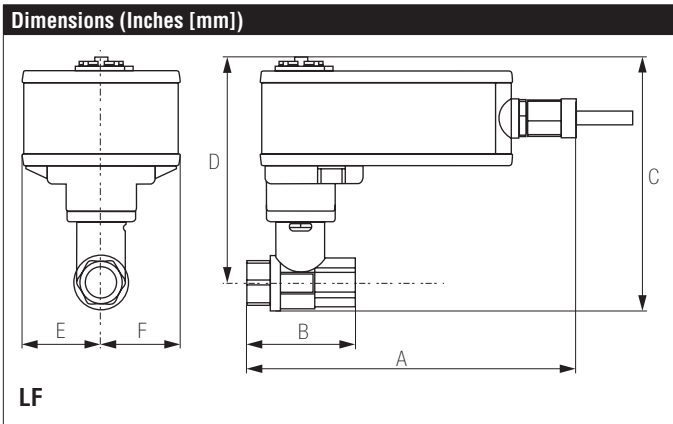

| A | B | C | D | E | F |
|------------|------------|-------------|-------------|------------|---|
| 7.9" [201] | 2.38" [60] | 6.06" [154] | 5.48" [139] | 1.25" [32] | |

TFRX24-3-S

Floating Point, Spring Return, 24 V



| Technical Data | |
|-----------------------------------|--|
| Power Supply | 24 VAC, ±20%, 50/60 Hz, 24 VDC, ±10% |
| Power Consumption Running | 2.5 W |
| Power Consumption Holding | 1 W |
| Transformer Sizing | 4 VA (class 2 power source) |
| Electrical Connection | (2) 3ft [1m], 10ft [3m] or 16ft [5m] 18 GA appliance cables, with 1/2" conduit connectors |
| Overload Protection | electronic throughout 0° to 95° rotation |
| Input Impedance | 1000 Ω (0.6 W) |
| Feedback Output U | No Feedback |
| Angle of Rotation | Max. 95°, adjustable with mechanical stop |
| Direction of Rotation (Motor) | reversible with built-in switch |
| Direction of Rotation (Fail-Safe) | reversible with CW/CCW mounting |
| Position Indication | visual indicator, 0° to 95° (0° is full spring return position) |
| Running Time (Motor) | 95 sec |
| Running Time (Fail-Safe) | <25 sec |
| Ambient Humidity | max. 95% RH non-condensing |
| Ambient Temperature Range | -22°F to 122°F [-30°C to 50°C] |
| Storage Temperature Range | -40°F to 176°F [-40°C to 80°C] |
| Housing | NEMA 2, IP42, UL Enclosure Type 2 |
| Housing Material | UL94-5VA |
| Agency Listings† | cULus acc. to UL60730-1A/-2-14, CAN/CSA E60730-1:02, CE acc. to 2004/108/EC and 2006/95/EC |
| Noise Level (Motor) | <35 dB (A) |
| Noise Level (Fail-Safe) | <62 dB (A) |
| Servicing | maintenance free |
| Quality Standard | ISO 9001 |
| Weight | 1.8 lb [0.8 kg] |
| Auxiliary switch | 1 x SPDT, 3A resistive (0.5A inductive) @ 250 VAC, adjustable 0° to 95° |
| Degree of Protection IEC/EN | IP42 |

†Rated Impulse Voltage 800V, Type of action 1.AA, Control Pollution Degree 3

Date created, 03/14/2018 - Subject to change. © Belimo Aircontrols (USA), Inc.

Wiring Diagrams

INSTALLATION NOTES

- Actuators with appliance cables are numbered.
- Provide overload protection and disconnect as required.
- Actuators may be connected in parallel. Power consumption and input impedance must be observed.
- Actuators may also be powered by 24 VDC.
- Actuators Hot wire must be connected to the control board common. Only connect common to neg. (-) leg of control circuits. Terminal models (-T) have no-feedback.
- One built-in auxiliary switch (1x SPDT), for end position indication, interlock control, fan startup, etc.
- Meets cULus requirements without the need of an electrical ground connection.

WARNING! LIVE ELECTRICAL COMPONENTS!
 During installation, testing, servicing and troubleshooting of this product, it may be necessary to work with live electrical components. Have a qualified licensed electrician or other individual who has been properly trained in handling live electrical components perform these tasks. Failure to follow all electrical safety precautions when exposed to live electrical components could result in death or serious injury.

