

# B6500S-290, 2-Way, Characterized Control Valve

## Stainless Steel Ball and Stem



### Technical Data

Service	chilled, hot water, up to 60% glycol
Flow Characteristic	equal percentage
Controllable Flow Range	75°
Size [mm]	5" [125]
End Fitting	Pattern to mate with ANSI 125 flange
Body	cast iron - GG25
Ball	stainless steel
Stem	stainless steel
Stem Packing	EPDM (lubricated)
Seat	Teflon® PTFE
Seat O-ring	EPDM (lubricated)
Characterized Disc	stainless steel
Body Pressure Rating [psi]	ANSI 125, standard class B
ANSI Class	ANSI 125, standard class B
Number of Bolt Holes	8
Media Temperature Range (Water)	0°F to 250°F [-18°C to 120°C]
Max Differential Pressure (Water)	50 psi (345 kPa)
Close-Off Pressure	100 psi
Cv	290
Weight	75 lb [34 kg]
Leakage	0% for A to AB
Servicing	maintenance free

### Flow Pattern

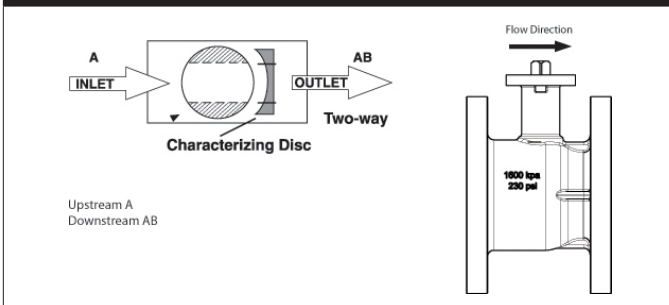

### Application

This valve is typically used in air handling units on heating or cooling coils, and fan coil unit heating or cooling coils. Some other common applications include Unit Ventilators, VAV box re-heat coils and bypass loops. This valve is suitable for use in a hydronic system with variable or constant flow.

### Suitable Actuators

	Non-Spring	Electronic Fail-Safe
B6500S-290	GRB(X)	GKRB(X)

### Dimensions (Inches [mm])

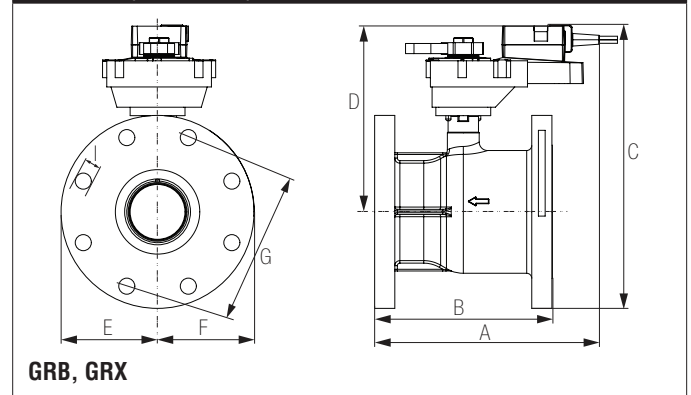

A	B	C	D	E	F	G	I
13.3" [338]	10.33" [262]	14.4" [366]	9.4" [239]	5" [127]		8.5" [217]	0.88" [22]

Date created, 02/27/2017 - Subject to change. © Belimo Aircontrols (USA), Inc.

**Dimensions (Inches [mm])**

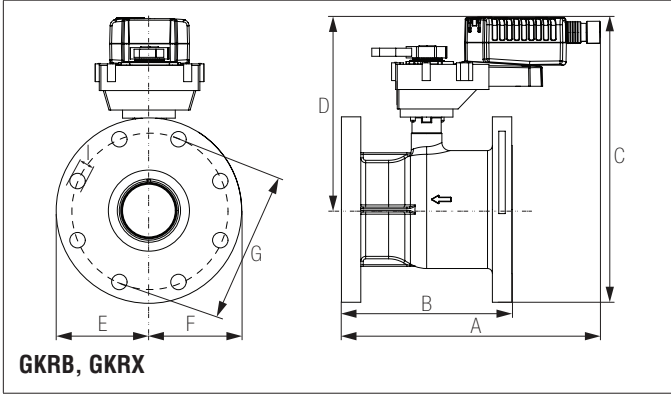

A	B	C	D	E	F	G	I
13.5"	10.33"	14.4"	9.7"	5" [127]		8.5"	0.88"
[343]	[262]	[366]	[246]			[217]	[22]

**Dimensions (Inches [mm])**

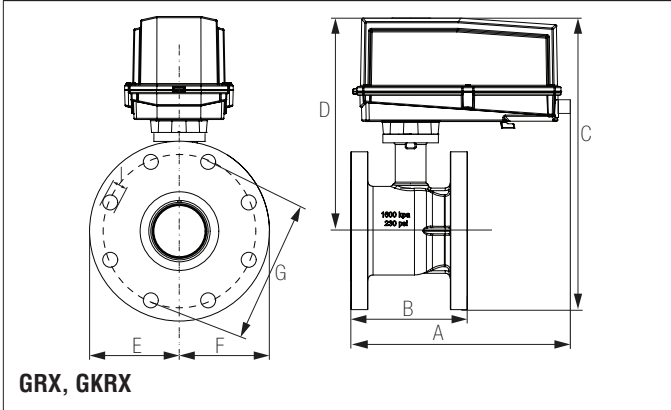

A	B	C	D	E	F	G	I
17.5"	10.33"	17.03"	13.60"	5" [127]		8.5"	0.88"
[444]	[262]	[433]	[345]			[217]	[22]

**Dimensions (Inches [mm])**

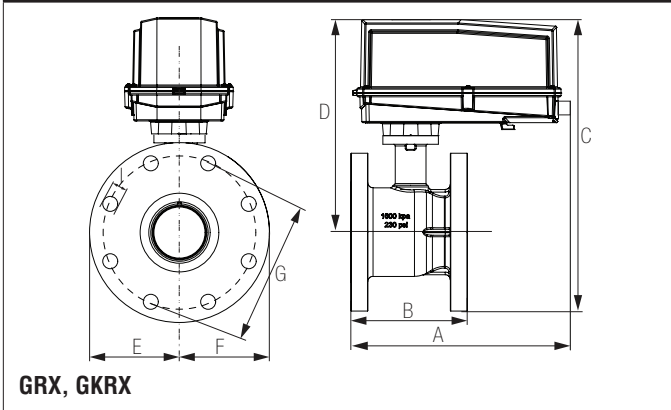

A	B	C	D	E	F	G	I
17.5"	10.33"	17.03"	13.60"	5" [127]		8.5"	0.88"
[444]	[262]	[433]	[345]			[217]	[22]

# GRX24-3







## On/Off Floating Point, Non-Spring Return, 24 V



Technical Data	
Power Supply	24 VAC $\pm$ 20%, 50/60 Hz, 24 VDC $\pm$ 10%
Power Consumption Running	4 W
Power Consumption Holding	2 W
Transformer Sizing	6 VA (class 2 power source)
Electrical Connection	3 ft, 18 GA plenum rated cable with 1/2" conduit connector protected NEMA 2 (IP54)
Overload Protection	electronic throughout 0° to 95° rotation
Operating Range Y	on/off, floating point
Input Impedance	600 $\Omega$
Angle of Rotation	90°, adjustable with mechanical stop
Direction of Rotation (Motor)	reversible with built-in switch
Position Indication	reflective visual indicator (snap on)
Manual Override	external push button
Running Time (Motor)	150 sec constant, independent of load
Humidity	5 to 95% RH non-condensing
Ambient Temperature Range	-22°F to +122°F [-30°C to +50°C]
Storage Temperature Range	-40°F to +176°F [-40°C to +80°C]
Housing	NEMA 2, IP54, UL enclosure type 2
Housing Material	UL94-5VA
Agency Listings†	cULus acc. to UL60730-1A/-2-14, CAN/CSA E60730-1:02, CE acc. to 2004/108/EC and 2006/95/EC
Noise Level (Motor)	<45 dB (A)
Servicing	maintenance free
Quality Standard	ISO 9001
Weight	3.4 lbs [1.55 kg]

Wiring Diagrams

### ✂️ INSTALLATION NOTES

-  Actuators with appliance cables are numbered.
-  Provide overload protection and disconnect as required.
-  Actuators may also be powered by 24 VDC.
-  Actuators Hot wire must be connected to the control board common. Only connect common to neg. (-) leg of control circuits. Terminal models (-T) have no-feedback.
-  Actuators may be connected in parallel if not mechanically linked. Power consumption and input impedance must be observed.
-  Meets cULus requirements without the need of an electrical ground connection.

 **WARNING! LIVE ELECTRICAL COMPONENTS!**  
 During installation, testing, servicing and troubleshooting of this product, it may be necessary to work with live electrical components. Have a qualified licensed electrician or other individual who has been properly trained in handling live electrical components perform these tasks. Failure to follow all electrical safety precautions when exposed to live electrical components could result in death or serious injury.

