

F6125HD+GW02

Resilient Seat, 304 Stainless Steel Disc



Technical Data

Service	chilled, hot water, up to 60% glycol
Flow Characteristic	modified equal percentage
Controllable Flow Range	90° rotation
Valve Size	5 " [125]
End Fitting	for use with ANSI class 125/150 flanges
Body	ductile iron ASTM A536
Body Finish	epoxy powder coated
Stem Packing	EPDM (lubricated)
Seat	EPDM
Shaft	416 stainless steel
Bushings	RPTFE
Disc	304 stainless steel
Body Pressure Rating	(415_with_label), standard class B
ANSI Class	125
Number of Bolt Holes	8
Lug Threads	3/4-10 UNC
Close-Off Pressure	200 psi
Rangeability	10:1 (for 30° to 70° range)
Maximum Velocity	12 FPS
Cv	1022
Weight	25 lb [11 kg]
Leakage	0%
Servicing	maintenance free

Flow Pattern

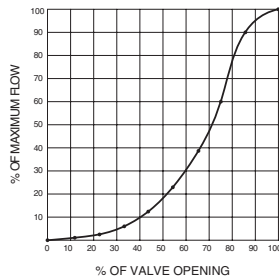

Application

Valve is designed for use in ANSI flanged piping systems to meet the needs of bi-directional high flow HVAC hydronic applications with 0% leakage. Typical applications include cooling tower bypass, primary flow change-over systems, and large air handler coil control. Valve face-to-face dimensions comply with API 609 & MSS-SP-67, Completely assembled and tested, Ready for installation.

Jobsite Note

Valve assembly should be stored in a weather protected area prior to installation. Reference the butterfly valve installation instruction for additional information.

Flow/Cv

Cv 10°	Cv 20°	Cv 30°	Cv 40°	Cv 50°	Cv 60°	Cv 70°	Cv 80°	Cv 90°
0.5	29	61	133	237	392	620	930	1022

Dimensions (Inches [mm])

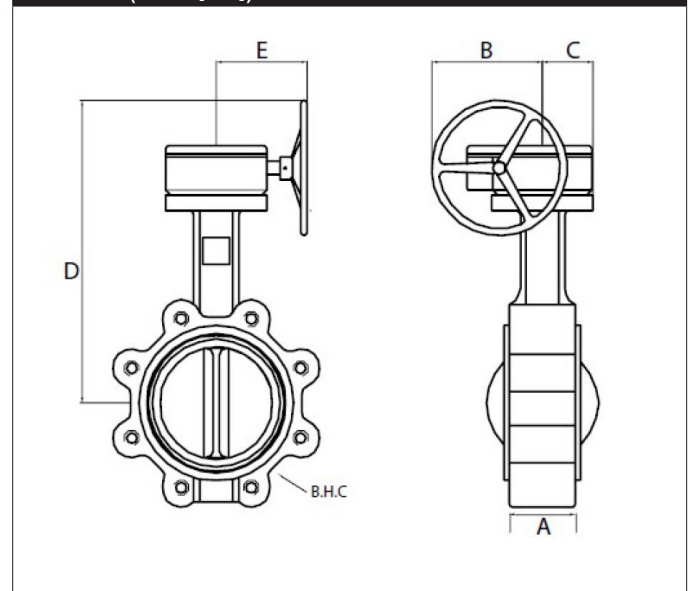

A	B	C	D	E
2.25" [57]	4.70" [119]	2.14" [54.4]	12.73" [323]	6.3" [160]

Date created, 10/30/2018 - Subject to change. © Belimo Aircontrols (USA), Inc.