

# F650HD, 2", 2-Way Butterfly Valve

Resilient Seat, 304 Stainless Steel Disc



### Technical Data

Service	chilled, hot water, up to 60% glycol
Flow Characteristic	modified equal percentage
Controllable Flow Range	90° rotation
Size [mm]	2" [50]
End Fitting	For use with ANSI Class 125/150 flanges
Body	ductile iron ASTM A536
Body Finish	epoxy powder coated
Stem Packing	EPDM (lubricated)
Seat	EPDM
Shaft	416 stainless steel
Bushings	RPTFE
Disc	304 stainless steel
Body Pressure Rating [psi]	ANSI 125, standard class B
Number of Bolt Holes	4
Lug Threads	5/8-11 UNC
Media Temperature Range (Water)	-22°F to 250°F [-30°C to 120°C]
Close-Off Pressure	200 psi
Rangeability	10:1 (for 30° to 70° range)
Maximum Velocity	12 FPS
Cv	115
Weight	5.3 lb [2.4 kg]
Leakage	0%
Servicing	maintenance free

### Flow Pattern

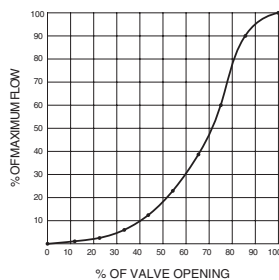

### Application

Valve is designed for use in ANSI flanged piping systems to meet the needs of bi-directional high flow HVAC hydronic applications with 0% leakage. Typical applications include cooling tower bypass, primary flow change-over systems, and large air handler coil control.

### Jobsite Note

Valve assembly should be stored in a weather protected area prior to installation. Reference the butterfly valve installation instruction for additional information.

### Flow/Cv

Cv 10°	Cv 20°	Cv 30°	Cv 40°	Cv 50°	Cv 60°	Cv 70°	Cv 80°	Cv 90°
0.06	3	7	15	27	44	70	105	115

### Suitable Actuators

	Non-Spring	Spring
F650HD	ARB(X), GRB(X)	AFRB(X)

### Dimensions (Inches [mm])

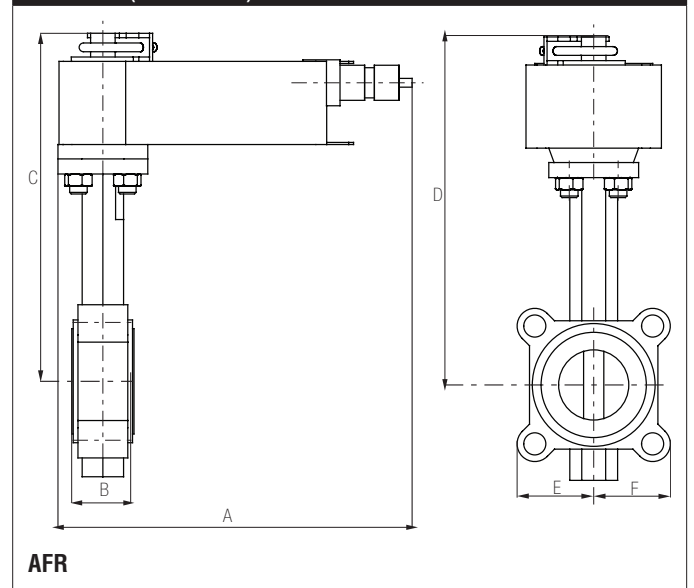

A	B	C	D	E	F
10.6" [270]	1.72" [43.7]	12.6" [320]	9.87" [251]	2.78" [71]	

Date created, 05/15/2017 - Subject to change. © Belimo Aircontrols (USA), Inc.

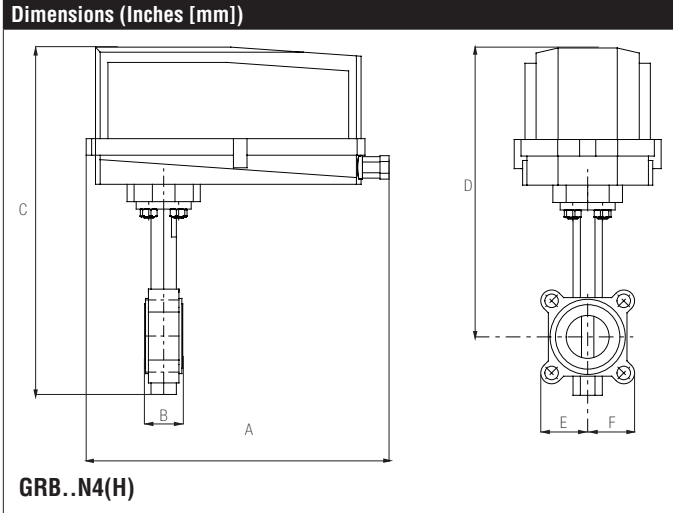

A	B	C	D	E	F
14.1" [358]	1.72" [43.7]	16.1" [375]	13.60" [345]	2.78" [71]	

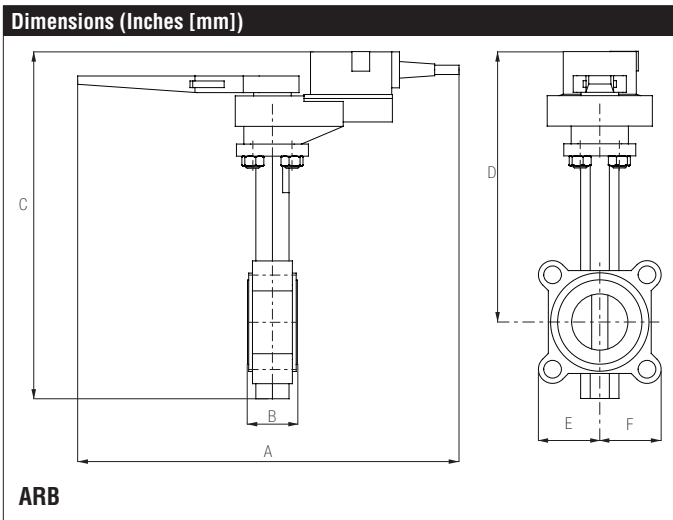

A	B	C	D	E	F
12.7" [323]	1.39" [35.3]	12.38" [314.4]	9.57" [243.1]	2.78" [71]	

# AFX24-MFT-S-X1

Modulating, Spring Return, 24 V, Multi-Function Technology®



Technical Data	
Power Supply	24 VAC, ±20%, 50/60 Hz, 24 VDC, -10% / +20%
Power Consumption Running	7.5 W
Power Consumption Holding	3 W
Transformer Sizing	10 VA (class 2 power source)
Electrical Connection	(2) 3ft [1m], 10ft [3m] or 16ft [5m] 18 GA appliance cables with or without 1/2" conduit connectors
Overload Protection	electronic throughout 0° to 95° rotation
Operating Range Y	2 to 10 VDC, 4 to 20 mA w/ ZG-R01 (500 Ω, 1/4 W resistor), variable (VDC, PWM, floating point, on/off)
Operating range Y variable	starting point DC 0.5...30 V end point DC 2.5...32 V
Feedback Output U	DC 2...10 V, Max. 0.5 mA, VDC variable
Angle of Rotation	95°, adjustable with mechanical end stop, 35° to 95°
Torque motor	180 in-lbs [20 Nm]
Direction of Rotation (Motor)	reversible with built-in switch
Direction of Rotation (Fail-Safe)	reversible with CW/CCW mounting
Position Indication	visual indicator, 0° to 95° (0° is full spring return position)
Manual Override	5 mm hex crank (3/16" Allen), supplied
Running Time (Motor)	default 150 sec, variable 70...220 sec
Running Time (Fail-Safe)	<20 sec
Override Control	min. position = 0% , mid. Position = 50% , max. position = 100% (Default)
Ambient Humidity	max. 95% RH non-condensing
Ambient Temperature Range	-22°F to 122°F [-30°C to 50°C]
Storage Temperature Range	-40°F to 176°F [-40°C to 80°C]
Housing	IP54, NEMA 2, UL Enclosure Type 2
Housing Material	zinc coated metal and plastic casing
Agency Listings†	cULus acc. to UL60730-1A/-2-14, CAN/CSA E60730-1:02, CE acc. to 2004/108/EC
Noise Level (Motor)	<40 dB (A)
Noise Level (Fail-Safe)	<62 dB (A)
Servicing	maintenance free
Quality Standard	ISO 9001
Weight	4.6 lb [2.1 kg]
Auxiliary switch	2 x SPDT, 3A resistive (0.5A inductive) @ 250 VAC, one set at 10°, one adjustable 10° to 90°
Degree of Protection IEC/EN	IP54

\*Variable when configured with MFT options.

†Rated Impulse Voltage 800V, Type of Action 1.AA.B, Control Pollution Degree 3.

Date created, 06/18/2018 - Subject to change. © Belimo Aircontrols (USA), Inc.

**Wiring Diagrams**

**⚠ WARNING! LIVE ELECTRICAL COMPONENTS!**  
 During installation, testing, servicing and troubleshooting of this product, it may be necessary to work with live electrical components. Have a qualified licensed electrician or other individual who has been properly trained in handling live electrical components perform these tasks. Failure to follow all electrical safety precautions when exposed to live electrical components could result in death or serious injury.

◆ Meets cULus requirements without the need of an electrical ground connection.

Ⓐ Actuators with appliance cables are numbered.

⚡ Apply only AC line voltage or only UL-Class 2 voltage to the terminals of auxiliary switches. Mixed or combined operation of line voltage/safety extra low voltage is not allowed.

1 Provide overload protection and disconnect as required.

3 Actuators may also be powered by 24 VDC.

4 Two built-in auxiliary switches (2x SPDT), for end position indication, interlock control, fan startup, etc.

5 Only connect common to negative (-) leg of control circuits.

7 A 500 Ω resistor (ZG-R01) converts the 4 to 20 mA control signal to 2 to 10 VDC.

8 Control signal may be pulsed from either the Hot (Source) or Common (Sink) 24 VAC line.

10 For triac sink the Common connection from the actuator must be connected to the Hot connection of the controller. Position feedback cannot be used with a triac sink controller; the actuator internal common reference is not compatible.

12 IN4004 or IN4007 diode. (IN4007 supplied, Belimo part number 40155).

46 Actuators may be controlled in parallel. Current draw and input impedance must be observed.

47 Master-Slave wiring required for piggy-back applications. Feedback from Master to control input(s) of Slave(s).

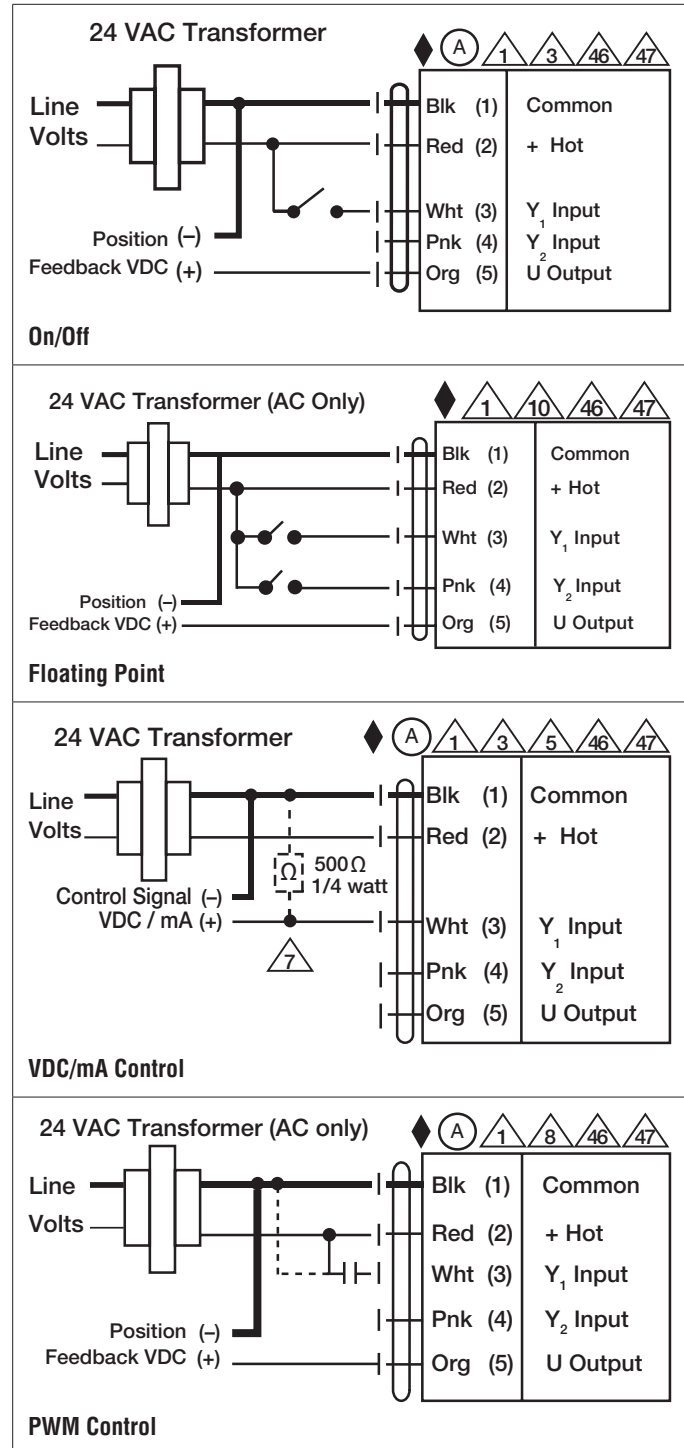

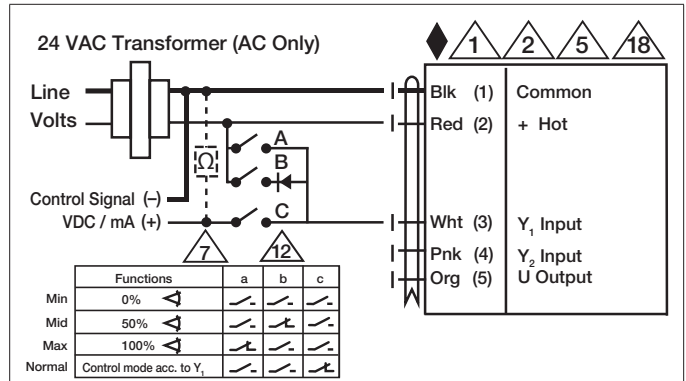

**Override Control**

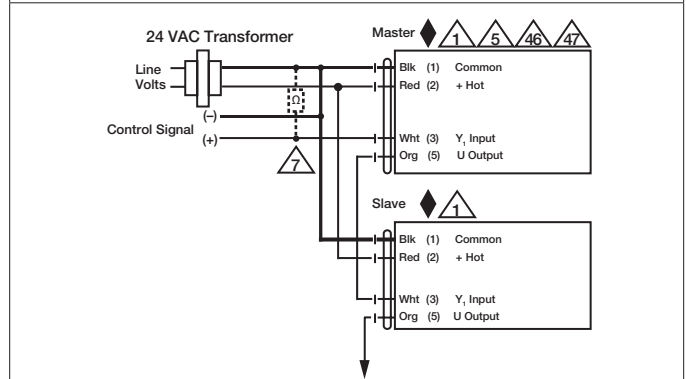

**Master - Slave**

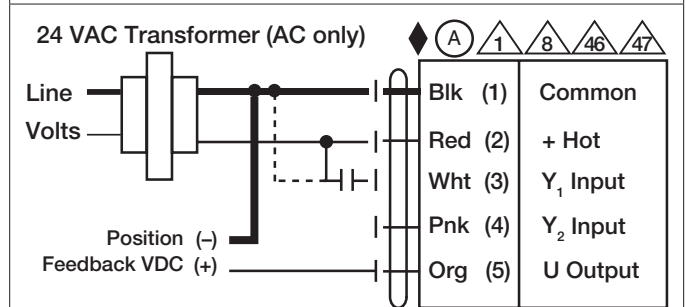

**PWM Control**

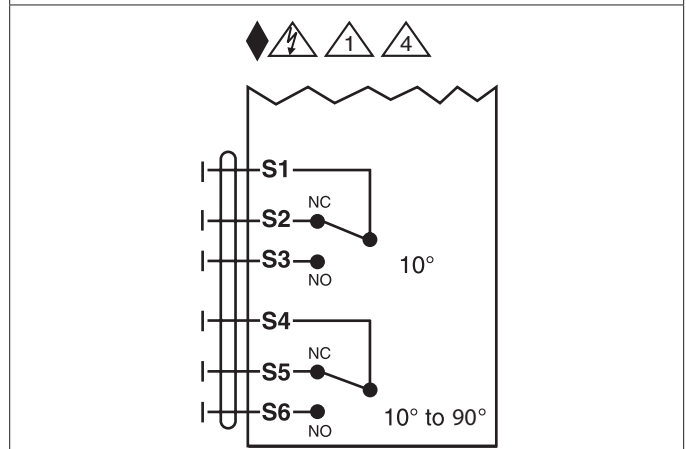

**Auxiliary Switches**

Date created, 06/18/2018 - Subject to change. © Belimo Aircontrols (USA), Inc.