

F650HD, 2", 2-Way Butterfly Valve

Resilient Seat, 304 Stainless Steel Disc

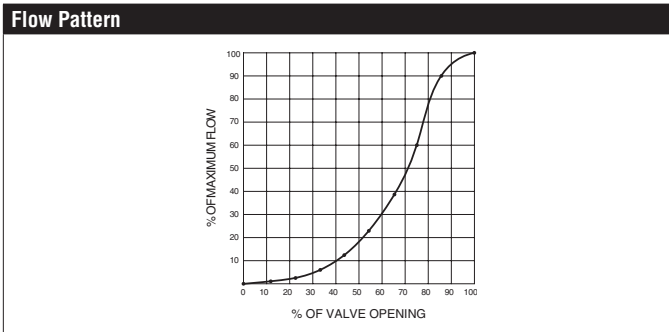

Technical Data	
Service	chilled, hot water, up to 60% glycol
Flow Characteristic	modified equal percentage
Controllable Flow Range	90° rotation
Size [mm]	2" [50]
End Fitting	For use with ANSI Class 125/150 flanges
Body	ductile iron ASTM A536
Body Finish	epoxy powder coated
Stem Packing	EPDM (lubricated)
Seat	EPDM
Shaft	416 stainless steel
Bushings	RPTFE
Disc	304 stainless steel
Body Pressure Rating [psi]	ANSI 125, standard class B
Number of Bolt Holes	4
Lug Threads	5/8-11 UNC
Media Temperature Range (Water)	-22°F to 250°F [-30°C to 120°C]
Close-Off Pressure	200 psi
Rangeability	10:1 (for 30° to 70° range)
Maximum Velocity	12 FPS
Cv	115
Weight	5.3 lb [2.4 kg]
Leakage	0%
Servicing	maintenance free



Application

Valve is designed for use in ANSI flanged piping systems to meet the needs of bi-directional high flow HVAC hydronic applications with 0% leakage. Typical applications include cooling tower bypass, primary flow change-over systems, and large air handler coil control.

Jobsite Note

Valve assembly should be stored in a weather protected area prior to installation. Reference the butterfly valve installation instruction for additional information.

Flow/Cv								
Cv 10°	Cv 20°	Cv 30°	Cv 40°	Cv 50°	Cv 60°	Cv 70°	Cv 80°	Cv 90°
0.06	3	7	15	27	44	70	105	115

Suitable Actuators		
	Non-Spring	Spring
F650HD	ARB(X), GRB(X)	AFRB(X)

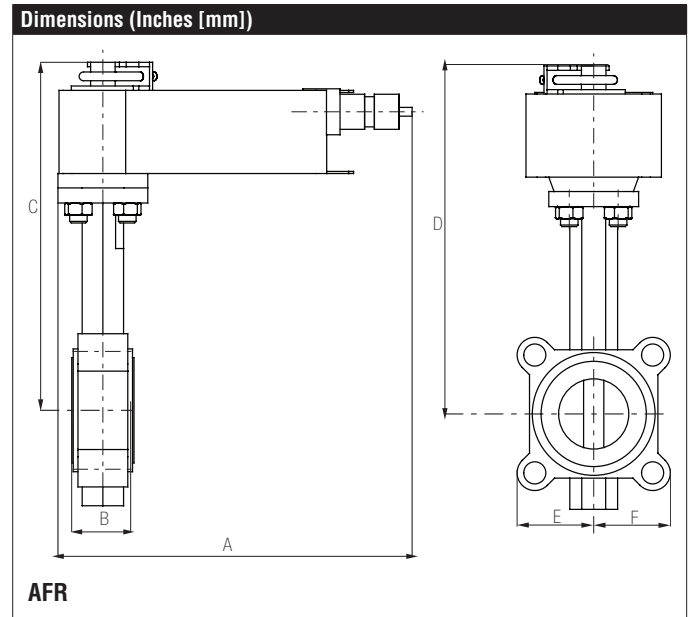

A	B	C	D	E	F
10.6" [270]	1.72" [43.7]	12.6" [320]	9.87" [251]	2.78" [71]	

Dimensions (Inches [mm])

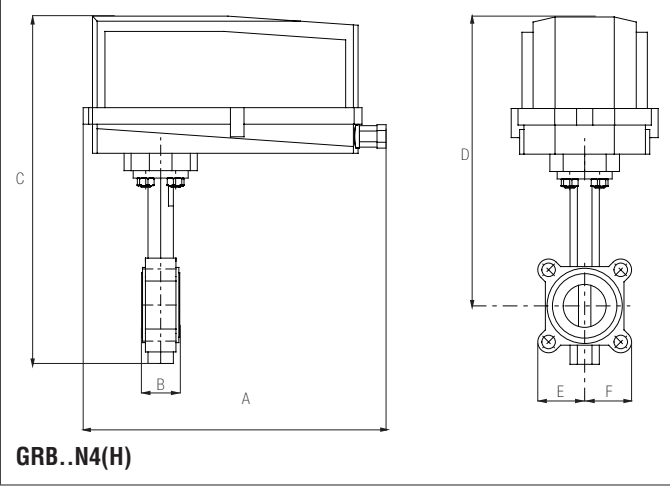

A	B	C	D	E	F
14.1" [358]	1.72" [43.7]	16.1" [375]	13.60" [345]	2.78" [71]	

Dimensions (Inches [mm])

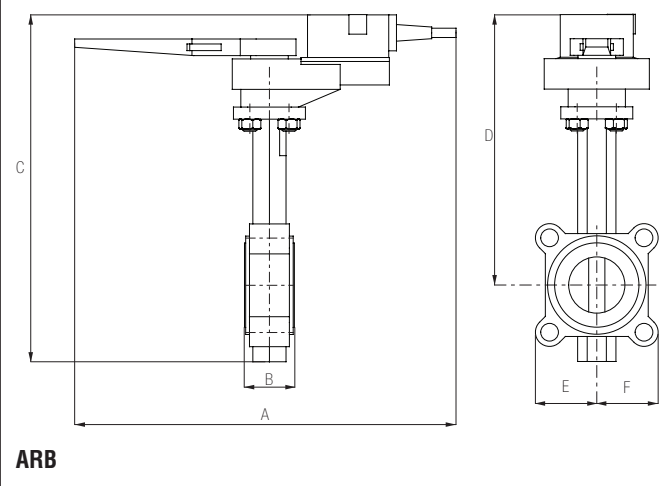

A	B	C	D	E	F
12.7" [323]	1.39" [35.3]	12.38" [314.4]	9.57" [243.1]	2.78" [71]	

AMB24-3-X1

On/Off, Floating Point, Non-Spring Return, 24 V

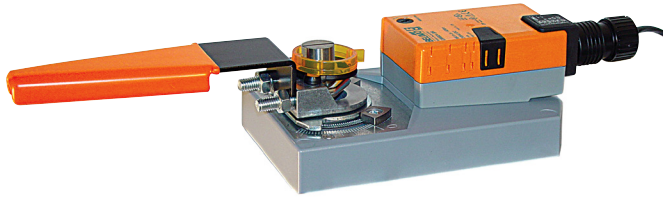

Technical Data	
Power Supply	24 VAC, ±20%, 50/60 Hz, 24 VDC, ±10%
Power Consumption Running	2.5 W
Power Consumption Holding	0.5 W
Transformer Sizing	5.5 VA (class 2 power source)
Electrical Connection	3ft [1m], 18 GA plenum rated cable with 1/2" conduit connector protected NEMA 2 (IP54)
Overload Protection	electronic throughout 0° to 90° rotation
Input Impedance	600 Ω
Angle of Rotation	Max. 95°, adjustable with mechanical stop
Torque motor	Min. 180 in-lbs [20 Nm]
Direction of Rotation (Motor)	reversible with built-in switch
Position Indication	reflective visual indicator (snap on)
Manual Override	external push button
Running Time (Motor)	90 sec
Ambient Humidity	5 to 95% RH non condensing (EN 60730-1)
Ambient Temperature Range	-22°F to 150°F [-30°C to 65°C]
Storage Temperature Range	-40°F to 176°F [-40°C to 80°C]
Housing	NEMA 2, IP54
Housing Material	UL94-5VA
Agency Listings†	cULus acc. to UL60730-1A/-2-14, CAN/CSA E60730-1:02, CE acc. to 2004/108/EC and 2006/95/EC
Noise Level (Motor)	<45 dB (A)
Servicing	maintenance free
Quality Standard	ISO 9001
Weight	2 lb [0.9 kg]

†Rated Impulse Voltage 800V, Type action 1.B , Control Pollution Degree 3.

Date created, 11/30/2017 - Subject to change. © Belimo Aircontrols (USA), Inc.

Wiring Diagrams

✂️ INSTALLATION NOTES

- Ⓐ Actuators with appliance cables are numbered.
- ⚠️ 1 Provide overload protection and disconnect as required.
- ⚠️ 3 Actuators may also be powered by 24 VDC.
- ⚠️ 6 Actuators Hot wire must be connected to the control board common. Only connect common to neg. (-) leg of control circuits. Terminal models (-T) have no-feedback.
- ⚠️ 11 Actuators may be connected in parallel if not mechanically linked. Power consumption and input impedance must be observed.
- ◆ Meets cULus requirements without the need of an electrical ground connection.

⚠️ WARNING! LIVE ELECTRICAL COMPONENTS!
 During installation, testing, servicing and troubleshooting of this product, it may be necessary to work with live electrical components. Have a qualified licensed electrician or other individual who has been properly trained in handling live electrical components perform these tasks. Failure to follow all electrical safety precautions when exposed to live electrical components could result in death or serious injury.

