

# F6600HD, 24", 2-Way Butterfly Valve

Resilient Seat, 304 Stainless Steel Disc



### Technical Data

Service	chilled, hot water, up to 60% glycol
Flow Characteristic	modified equal percentage
Controllable Flow Range	90° rotation
Valve Size	24 " [600]
End Fitting	for use with ANSI class 125/150 flanges
Body	ductile iron ASTM A536
Body Finish	epoxy powder coated
Stem Packing	EPDM (lubricated)
Seat	EPDM
Shaft	416 stainless steel
Bushings	RPTFE
Disc	304 stainless steel
Body Pressure Rating	{415_with_label}, {8368}
ANSI Class	125
Number of Bolt Holes	20
Lug Threads	1 1/4-7 UNC
Media Temperature Range (Water)	-22°F to 250°F [-30°C to 120°C]
Close-Off Pressure	150 psi
Rangeability	10:1 (for 30° to 70° range)
Maximum Velocity	12 FPS
Cv	43116
Weight	414.5 lb [188 kg]
Leakage	0%
Servicing	maintenance free

### Flow Pattern

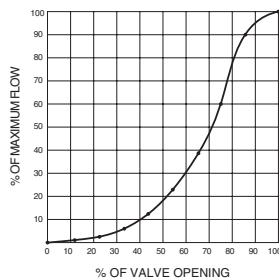

### Application

Valve is designed for use in ANSI flanged piping systems to meet the needs of bi-directional high flow HVAC hydronic applications with 0% leakage. Typical applications include cooling tower bypass, primary flow change-over systems, and large air handler coil control. Valve face-to-face dimensions comply with API 609 & MSS-SP-67, Completely assembled and tested, Ready for installation.

### Jobsite Note

Valve assembly should be stored in a weather protected area prior to installation. Reference the butterfly valve installation instruction for additional information.

### Flow/Cv

Cv 10°	Cv 20°	Cv 30°	Cv 40°	Cv 50°	Cv 60°	Cv 70°	Cv 80°	Cv 90°
22	1222	2587	5605	9989	16528	26157	39236	43116

### Suitable Actuators

	Non-Spring
F6600HD	SY11

### Dimensions (Inches [mm])

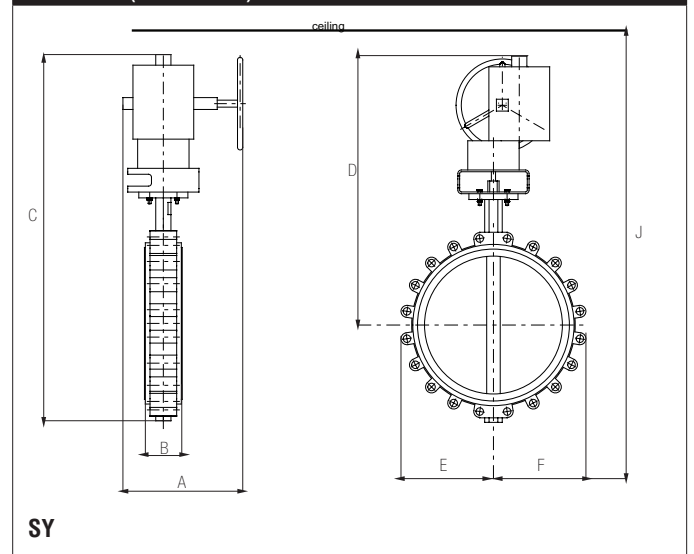

A	B	C	D	E	F	J
18.63"	6.12"	59.51"	42.25"	16.32"	[414]	68.37"
[473.2]	[156]	[1511]	[1073]			[1736]

Date created, 06/26/2018 - Subject to change. © Belimo Aircontrols (USA), Inc.

# SY11-120MFT

Modulating, Non-Spring Return, 120 V, for 2 to 10VDC or 4 to 20 mA



## Application

SY Series actuators are fractional horsepower devices, and utilize full-wave power supplies. Observe wire sizing and transformer sizing requirements. Proportional models CANNOT be connected to Belimo direct coupled (AF, AM, GM...etc) actuator power supplies or any type of half-wave device. You MUST use a separate, dedicated transformer or power supply to power the SY actuator. Please do not connect other automation equipment to the dedicated SY supply source. You MUST use four wires (plus a ground) to control a proportional control SY actuator (See SY Wiring Section).

Technical Data	
Power Supply	120 VAC, $\pm 10\%$ , 50/60 Hz
Power Consumption Running	318 W
Electrical Connection	terminal blocks
Overload Protection	thermally protected 135°C cut-out
Operating Range Y	2 to 10 VDC, 4 to 20 mA w/ ZG-R01 (500 $\Omega$ , 1/4 W resistor) between 0% and 100%
Input Impedance	100 k $\Omega$
Feedback Output U	DC 2...10 V
Angle of Rotation	90°
Torque motor	26700 in-lbs [3000 Nm]
Duty cycle	50%
Direction of Rotation (Motor)	reversible with built-in switch
Position Indication	top mounted domed indicator
Manual Override	hand wheel
Running Time (Motor)	58 sec
Internal Humidity Control	resistive heating element
Ambient Humidity	5 to 100% RH (UL Type 4)
Ambient Temperature Range	-22...150 °F [-30...65 °C]
Storage Temperature Range	-40...176 °F [-40...80 °C]
Housing	IP66/67, NEMA 4X, UL Enclosure Type 4
Housing Material	die cast aluminum alloy
Gear Train	high alloy steel gear sets, self locking
Agency Listings†	ISO, CE, cCSAus
Noise Level (Motor)	<45 dB (A)
Servicing	maintenance free
Quality Standard	ISO 9001
Weight	158.7 lb [72 kg]
Auxiliary switch	2 x SPDT, 3A resistive (0.5A inductive) @ 250 VAC, one set at 10°, one set at 85°
Degree of Protection IEC/EN	IP66/67

### Wiring Diagrams

#### INSTALLATION NOTES

- 60** Do not change sensitivity or dip switch setting with power applied.
- 61** Power supply Common/Neutral and Control Signal “-” wiring to a common is prohibited. Terminals 4 and 6 need to be wired separately.
- 62** Isolation relays must be used in parallel connection of multiple actuators using a common control signal inputs. The relays should be DPDT.
- 63** Isolation relays are required in parallel applications. The reason parallel applications need isolation relays is that the motor uses two sets of windings, one for each direction. When one is energized to turn the actuator in a specific direction a voltage is generated in the other due to the magnetic field created from the first. It's called back EMF. This is not an issue with one actuator because the voltage generated in the second winding isn't connected to anything so there is no flow. On parallel applications without isolation, this EMF voltage energizes the winding it is connected to on the other actuators in the system, the actuators are trying to turn in both directions at once. The EMF voltage is always less than the supply voltage due to the resistance of the windings, so while the actuator still turns in the commanded direction, the drag from the other reduces the torque output and causes overheating.

**WARNING! LIVE ELECTRICAL COMPONENTS!**  
 During installation, testing, servicing and troubleshooting of this product, it may be necessary to work with live electrical components. Have a qualified licensed electrician or other individual who has been properly trained in handling live electrical components perform these tasks. Failure to follow all electrical safety precautions when exposed to live electrical components could result in death or serious injury.

