

# F680HD, 3", 2-Way Butterfly Valve

## Resilient Seat, 304 Stainless Steel Disc



### Technical Data

Service	chilled, hot water, up to 60% glycol
Flow Characteristic	modified equal percentage
Controllable Flow Range	90° rotation
Size [mm]	3" [80]
End Fitting	For use with ANSI Class 125/150 flanges
Body	ductile iron ASTM A536
Body Finish	epoxy powder coated
Stem Packing	EPDM (lubricated)
Seat	EPDM
Shaft	416 stainless steel
Bushings	RPTFE
Disc	304 stainless steel
Body Pressure Rating [psi]	ANSI 125, standard class B
Number of Bolt Holes	4
Lug Threads	5/8-11 UNC
Media Temperature Range (Water)	-22°F to 250°F [-30°C to 120°C]
Close-Off Pressure	200 psi
Rangeability	10:1 (for 30° to 70° range)
Maximum Velocity	12 FPS
Cv	302
Weight	6.8 lb [3.1 kg]
Leakage	0%
Servicing	maintenance free

### Flow Pattern

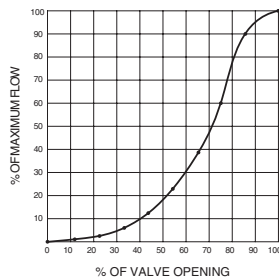

### Application

Valve is designed for use in ANSI flanged piping systems to meet the needs of bi-directional high flow HVAC hydronic applications with 0% leakage. Typical applications include cooling tower bypass, primary flow change-over systems, and large air handler coil control.

### Jobsite Note

Valve assembly should be stored in a weather protected area prior to installation. Reference the butterfly valve installation instruction for additional information.

### Flow/Cv

Cv 10°	Cv 20°	Cv 30°	Cv 40°	Cv 50°	Cv 60°	Cv 70°	Cv 80°	Cv 90°
0.2	9	18	39	70	116	183	275	302

### Suitable Actuators

	Non-Spring	Spring	Electronic Fail-Safe
F680HD	GRB(X)	2*AFB(X)	GKRB(X)

### Dimensions (Inches [mm])

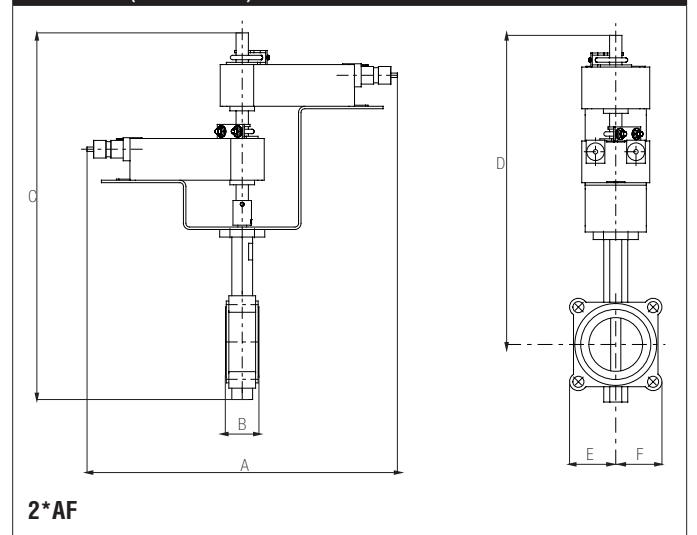

A	B	C	D	E	F
16.9" [429]	1.81" [46]	21.38" [544]	17.63" [448]	3.75" [95]	

Date created, 05/12/2017 - Subject to change. © Belimo Aircontrols (USA), Inc.

**Dimensions (Inches [mm])**

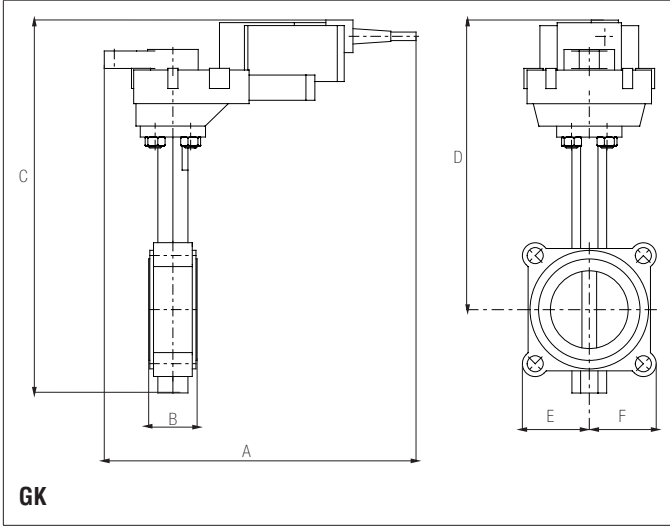

A	B	C	D	E	F
12.7" [323]	1.81" [46]	15.10" [384]	11.5" [292]	3.75" [95]	

**Dimensions (Inches [mm])**

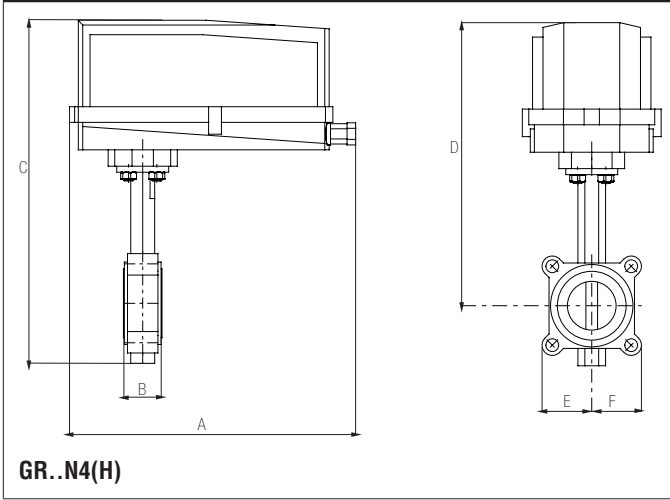

A	B	C	D	E	F
14.1" [358]	1.81" [46]	18.39" [467.1]	14.8" [328]	3.75" [95]	

# F680HD, 3", 2-Way Butterfly Valve

Resilient Seat, 304 Stainless Steel Disc

**Dimensions (Inches [mm])**

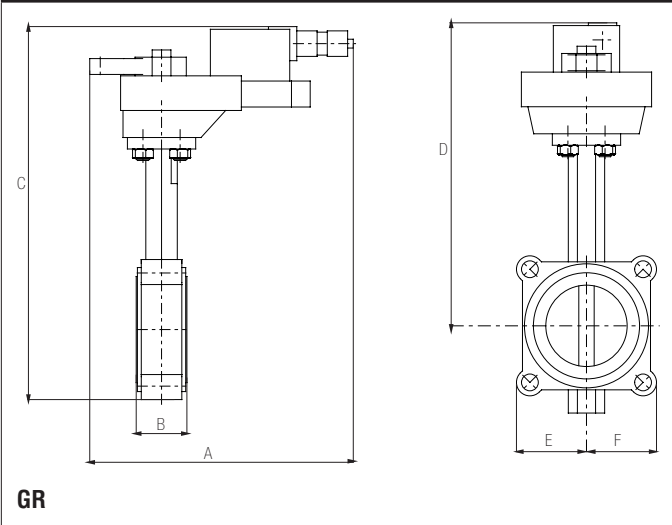

**GR**

A	B	C	D	E	F
12.7" [323]	1.81" [46]	15.10" [384]	11.16" [283]	2.6" [66]	

# GRCX24-3-T N4

NEMA 4X, On/Off, Floating Point Control, Non-Spring Return, 24 V

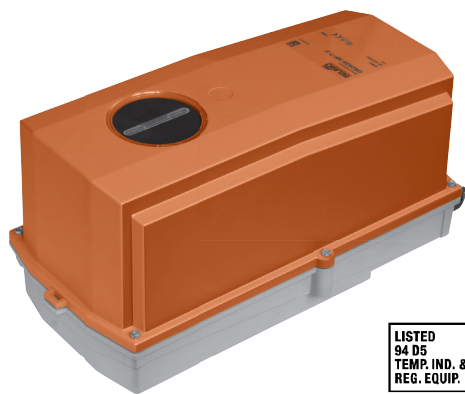

Technical Data	
Power Supply	24 VAC, ±20%, 50/60 Hz, 24 VDC, ±10%
Power Consumption Running	8 W
Power Consumption Holding	2.5 W
Transformer Sizing	11 VA (class 2 power source)
Electrical Connection	terminal block
Overload Protection	electronic throughout 0° to 90° rotation
Input Impedance	600 Ω
Angle of Rotation	90°, adjustable with mechanical stop
Direction of Rotation (Motor)	reversible with built-in switch
Position Indication	dial
Manual Override	under cover
Running Time (Motor)	35 sec, constant, independent of load
Ambient Humidity	5 to 95% RH non-condensing
Ambient Temperature Range	-22°F to 122°F [-30°C to 50°C]
Storage Temperature Range	-40°F to 176°F [-40°C to 80°C]
Housing	NEMA 4X, IP66/67, UL Enclosure Type 4X
Housing Material	polycarbonate
Agency Listings†	cULus acc. to UL60730-1A/-2-14, CAN/CSA E60730-1:02, CE acc. to 2004/108/EC and 2006/95/EC
Noise Level (Motor)	<45 dB (A)
Servicing	maintenance free
Quality Standard	ISO 9001
Weight	9.9 lb [4.5 kg]
Degree of Protection IEC/EN	IP66/67

†Rated Impulse Voltage 800V, Type of action 1.AA, Control Pollution Degree 3

**Wiring Diagrams**
**INSTALLATION NOTES**

- Provide overload protection and disconnect as required.
- Actuators may be connected in parallel. Power consumption and input impedance must be observed.
- Actuators may also be powered by 24 VDC.
- Actuators Hot wire must be connected to the control board common. Only connect common to neg. (-) leg of control circuits. Terminal models (-T) have no-feedback.
- Actuators are provided with a numbered screw terminal strip instead of a cable.
- Meets cULus requirements without the need of an electrical ground connection.

**WARNING! LIVE ELECTRICAL COMPONENTS!**  
 During installation, testing, servicing and troubleshooting of this product, it may be necessary to work with live electrical components. Have a qualified licensed electrician or other individual who has been properly trained in handling live electrical components perform these tasks. Failure to follow all electrical safety precautions when exposed to live electrical components could result in death or serious injury.

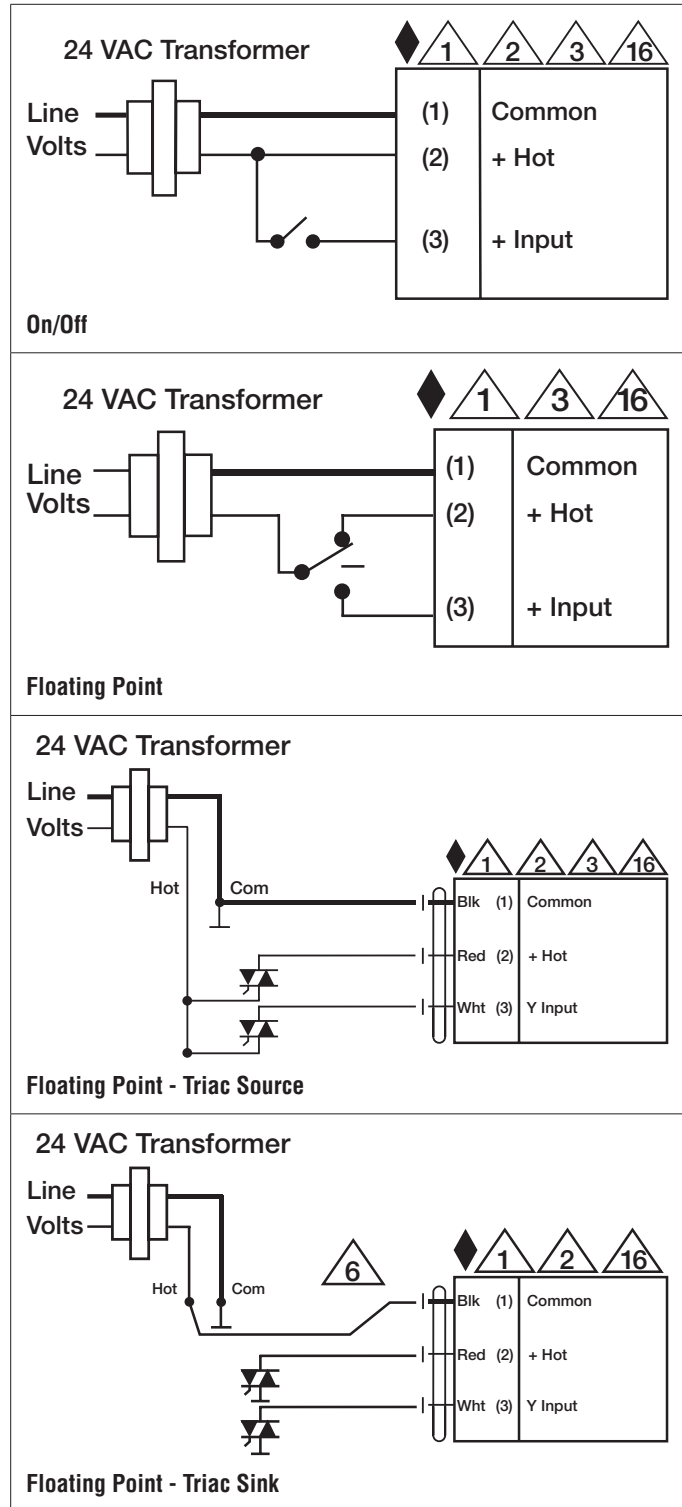

Date created, 01/30/2018 - Subject to change. © Belimo Aircontrols (USA), Inc.