

# FSAF24A

On/Off, Spring Return, 24 VAC/DC



## Technical Data

Power Supply	24 VAC, ±10%, 50/60 Hz, 24 VDC, -0% / +50%
Power Consumption Running	23 W, 32 VA
Power Consumption Holding	6.5 W, 11 VA, End stop 47 VA, 2 A slow blow fuse *
Transformer Sizing	40 VA (class 2 power source)
Shaft Diameter	1/2" to 1.05" round, centers on 3/4" with insert, 1.05" without insert
Electrical Connection	3ft [1m], 18 GA appliance cable with 1/2" conduit connector
Overload Protection	electronic throughout 0° to 95° rotation
Electrical Protection	actuators are double insulated
Angle of Rotation	95°
Torque motor	180 in-lbs [20 Nm]
Direction of Rotation (Motor)	reversible with CW/CCW mounting
Direction of Rotation (Fail-Safe)	reversible with CW/CCW mounting
Position Indication	visual indicator, 0° to 95° (0° is full spring return position)
Running Time (Motor)	<25 sec
Running Time (Fail-Safe)	<15 sec
Ambient Humidity	5 to 95% RH non condensing (EN 60730-1)
Ambient Temperature Range	32...122 °F [0...50 °C]
Storage Temperature Range	-40...176 °F [-40...80 °C]
Housing	IP40, NEMA 1
Housing Material	zinc coated steel
Gears	steel, permanently lubricated
Agency Listings†	cULus listed to UL60730-1A:02; UL 60730-2-14:02 and CAN/CSA-E60730-1:02; Listed to UL 2043 - suitable for use in air plenums per Section 300.22(c) of the NEC and Section 602.2 of the IMC
Noise Level (Motor)	inaudible holding, running 70 dB (A)
Noise Level (Fail-Safe)	inaudible holding, spring 73 dB (A)
Servicing	maintenance free
Quality Standard	ISO 9001, RoHS (EU-Directive 2011/65/EU)
Weight	5.5 lb [2.5 kg]

† UL File XAPX.E108966

**Fire & Smoke, 180 in-lb at 350°F for 30 min., 25 sec. drive, 15 sec. spring**

## Application

The FSAF\_A actuators provide true spring return operation for reliable fail-safe application and positive close-off on UL555S dampers. The spring return system provides constant torque to the damper with and without power applied to the actuator. The FSAF\_A series provides 95° of rotation and is provided with a graduated position indicator showing 0 to 95°.

## Operation

The FSAF\_A series actuators are mounted to the damper axle shaft or jackshaft (1/2" to 1.05") via a cold-weld clamp. Teeth in the clamp and V-bolt dig into the metal of both solid and hollow shafts maintaining a perfect connection. The specially designed clamp will not crush hollow shafts. The bottom end of the actuator is held by an anti-rotation strap or by a stud provided by the damper manufacturer. The actuator is mounted in its fail safe position with the damper blade(s) closed. Upon applying power, the actuator drives the damper to the open position. The internal spring is tensioned at the same time. If the power supply is interrupted, the spring moves the damper back to its fail-safe position.

Note on linkage kits. The correct leg kit for the FSAF\_A series is the older ZG-AF US as the actuator has a classic AF frame. However, the spline is the new generation type and the crank arm required is the KH-AFB.

## Dimensions (Inches[mm])

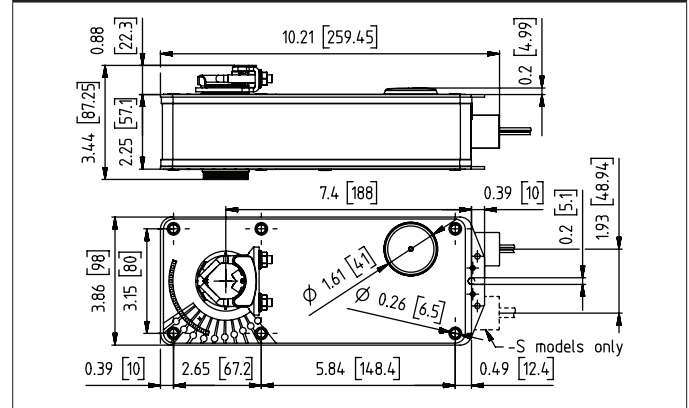

## Safety Notes

\* Neither UL nor Belimo require local over-current protection. The FSAF\_A actuators draw higher peak current when driving against any type of stop. After 10 seconds current drops to the lower holding level. If used, this requires the value of a local fuse or breaker to be increased to avoid nuisance opening or tripping. A 2 A slow blow should be used for 24 VAC. A 0.5 A slow blow should be used for 120 VAC. A 0.25 A slow blow should be used for 230 VAC and a 0.3 A slow blow for 208 VAC.

Transformers:

Note that while a 24 V 100 VA transformer would handle 3 actuators run current, a 4 A breaker or plug fuse is insufficient. A 6 A slow blow would be required.

Accessories	
AF-P	Anti-rotation bracket AF/NF.
SH8	Push rod for KG6 & KG8 ball joints (36" L, 5/16" diameter).
TOOL-06	8 mm and 10 mm wrench.
ZG-100	Univ. right angle bracket (17" H x 11-1/8" W x 6" base).
ZG-101	Univ. right angle bracket (13" H x 11" W x 7-7/16" base).
ZG-102	Dual actuator mounting bracket.
ZG-AF US	Classic AF/NF crankarm adaptor kit.
ZG-AFB118	AFB(X)/NFB(X) crankarm adaptor kit.
ZS-100	Weather shield - galvaneal (13" L x 8" W x 6" D).
ZS-150	Weather shield - PC w/ foam seal (16" L x 8-3/8" W x 4" D).
ZS-260	Explosion proof housing.
ZS-300	NEMA 4X, 304 stainless steel enclosure.
BAE165 US	165° F electric thermal sensor, SPST, normally closed.
S2A-F US	Auxiliary switch, 2x SPDT, 3A (0.5A inductive) @250 VAC max.

### Typical Specification

All smoke and combination fire and smoke dampers shall be provided with Belimo FSTF, FSLF, FSNF, or FSAF actuators. All substitutions must be approved before submission of bid. Damper and actuator shall have UL 555S Listing for 250°F &/or 350°F. Actuator shall have been tested to UL 2043 per requirements of IMC 602.2 and NEC 300.22 (c). Where position indication is required -S models with auxiliary switches or damper blade switches will be provided per code requirements.

### Wiring Diagrams

- Provide overload protection and disconnect as required.
- Actuators may be powered in parallel. Power consumption must be observed.
- Ground present on some models.
- Meets cULus requirements without the need of an electrical ground connection.

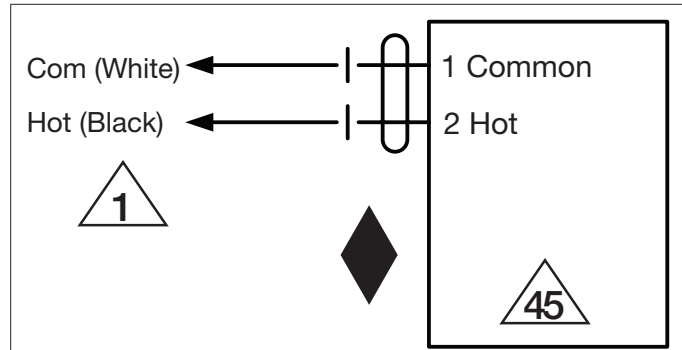

**24 VAC/DC**

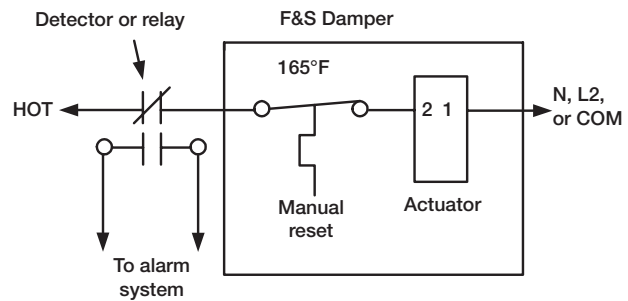

**Typical containment damper control wiring**

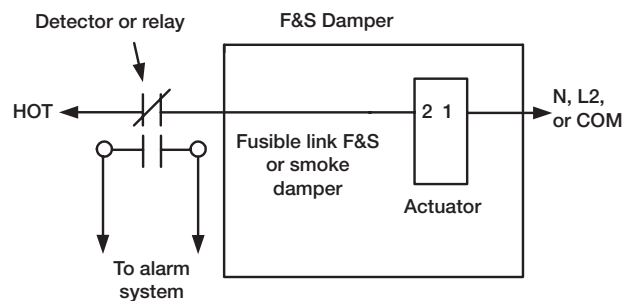

**Typical smoke or fusible link damper wiring**

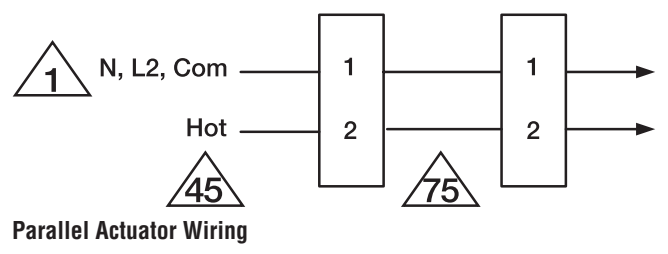

**Parallel Actuator Wiring**