

G215S-G, 2-Way, Globe Valve, Stainless Steel Trim



Technical Data

Service	chilled or hot water, up to 60% glycol, steam
Flow Characteristic	modified equal percentage
Controllable Flow Range	stem up - open A to AB
Size [mm]	0.5" [15]
End Fitting	NPT female ends
Body	bronze
Stem	316 stainless steel
Stem Packing	EPDM O-ring
Seat	316 stainless steel
Plug	316 stainless steel
Body Pressure Rating [psi]	ANSI 250
ANSI Class	ANSI 250 (up to 400 psi below 150°F)
Max Inlet Pressure (Steam)	100 psi (690 kPa)
Media Temperature Range (Water)	20°F to 338°F [-7°C to 170°C]
Media Temperature Range (Steam)	32°F to 338°F [0°C to 170°C]
Maximum Differential Pressure (Steam)	50 psi (345 kPa)
Max Differential Pressure (Water)	35 psi (241 kPa)
Rangeability	100:1
Cv	2.2
Leakage	ANSI Class VI
Servicing	repack kits available

Flow Pattern



Application

This valve is typically used in air handling units on heating or cooling coils, and fan coil unit heating or cooling coils. Some other common applications include unit ventilators, VAV box re-heat coils and bypass loops. This valve is suitable for use in hydronic systems with variable flow. Bronze and stainless steel trim valves can be used for steam applications, depending on actuator and close-off combinations.

Suitable Actuators

	Non-Spring	Spring	Electronic Fail-Safe
G215S-G	LVB(X)	LF	LVKB(X)

Dimensions (Inches [mm])

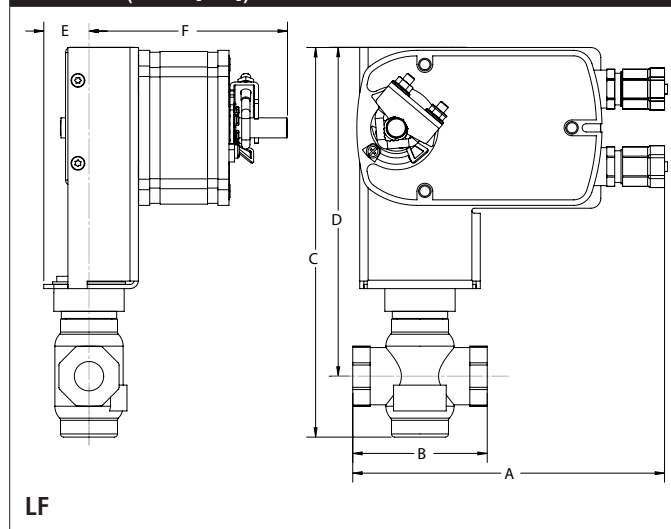

A	B	C	D	E	F
7.8" [200]	3.4" [86]	9.69" [246]	8.18" [208]	1.18" [30]	4.94" [125]

Piping

The valves should be mounted in a weather-protected area in a location that is within the ambient limits of the actuator. Allow sufficient room for valve with actuator and for service. The G2 and G3 preferred mounting position of the valve is with the valve stem vertical above the valve body, for maximum life. However, the assemblies can be mounted with the valve stem vertical or horizontal in relation to the pipe. The actuators should never be mounted underneath the valve, as condensation can build up and result in a failure of the actuators.

G215S-G, 2-Way, Globe Valve, Stainless Steel Trim

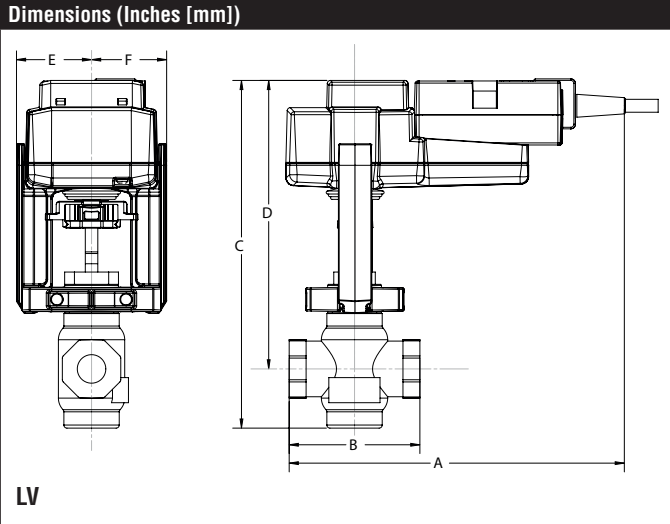

A	B	C	D	E	F
8.6" [218]	3.4" [86]	8.9" [226.1]	7.39" [188]	1.93" [49]	

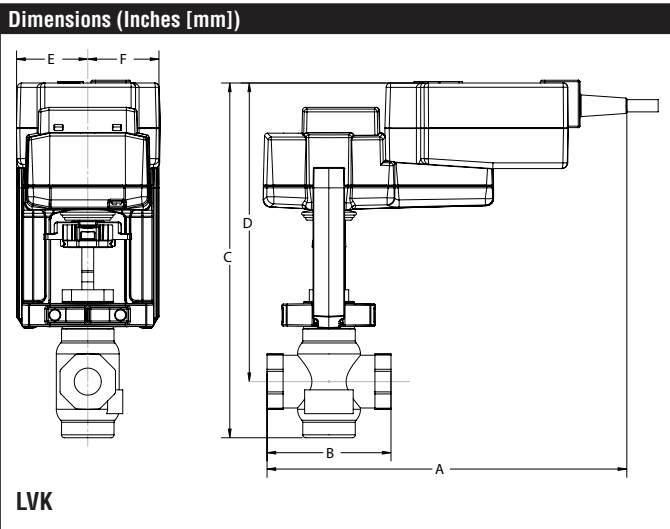

A	B	C	D	E	F
9.7" [247]	3.4" [86]	9.6" [244]	8.06" [205]	1.93" [49]	

LVKX24-MFT

Modulating, Fail-Safe Operation, Linear, 24 V, Multi-Function Technology®

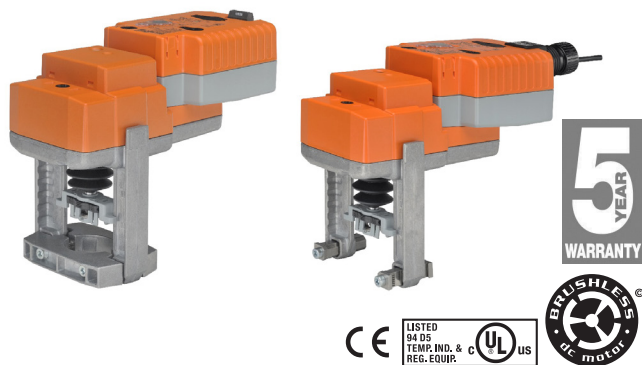

Technical Data

Power Supply	24 VAC, ±20%, 50/60 Hz, 24 VDC, ±10%
Power Consumption Running	2.5 W
Power Consumption Holding	1.5 W
Transformer Sizing	6 VA (class 2 power source)
Electrical Connection	3ft [1m], 18 GA plenum rated cable with 1/2" conduit connector protected NEMA 2 (IP54)
Overload Protection	electronic throughout full stroke
Electrical Protection	actuators are double insulated
Operating Range Y	2 to 10 VDC, 4 to 20 mA w/ ZG-R01 (500 Ω, 1/4 W resistor), variable (VDC, PWM, floating point, on/off)
Input Impedance	100 k Ω for 2 to 10 VDC (0.1 mA), 500 Ω for 4 to 20 mA, 1500 Ω for PWM, floating point and On/Off
Feedback Output U	2 to 10 VDC
Stroke	0.75" [19 mm]
Actuating force motor	112 lbf [500 N]
Direction of Rotation (Motor)	reversible with switch
Direction of Rotation (Fail-Safe)	reversible with switch
Position Indication	stroke indicator on bracket
Manual Override	4 mm hex crank (shipped w/actuator)
Running Time (Motor)	90 sec (default), Optional (90 or 150 sec)
Running Time (Fail-Safe)	35 sec
Bridge Time	2 sec delay before fail-safe activates
Pre-charging Time	5 to 20 seconds
Ambient Humidity	5 to 95% RH non-condensing
Ambient Temperature Range	-22°F to 122°F [-30°C to 50°C]
Storage Temperature Range	-40°F to 176°F [-40°C to 80°C]
Housing	NEMA 2, IP54, UL Enclosure Type 2
Housing Material	Aluminum die cast and plastic casing
Agency Listings†	cULus acc. to UL60730-1A/-2-14, CAN/CSA E60730-1:02, CE acc. to 2004/108/EC and 2006/95/EC
Noise Level (Motor)	<55 dB (A)
Noise Level (Fail-Safe)	<60 dB (A)
Servicing	maintenance free
Quality Standard	ISO 9001
Weight	3.5 lb [1.6 kg]

† Use flexible metal conduit. Push the listed conduit fitting device over the actuator's cable to butt against the enclosure. Screw in conduit connector. Jacket the actuators input wiring with listed flexible conduit. Properly terminate the conduit in a suitable junction box. Rated impulse Voltage 800V. Type of action 1. Control pollution degree 3.

†Rated Impulse Voltage 800V, Type of action 1.AA, Control Pollution Degree 3

Wiring Diagrams
INSTALLATION NOTES

- Actuators may be connected in parallel. Power consumption and input impedance must be observed.
- Actuators may also be powered by 24 VDC.
- A 500 Ω resistor (ZG-R01) converts the 4 to 20 mA control signal to 2 to 10 VDC.
- Control signal may be pulsed from either the Hot (Source) or Common (Sink) 24 VAC line.
- For triac sink the common connection from the actuator must be connected to the hot connection of the controller. Contact closures A & B also can be triacs. A & B should both be closed for the triac source and open for triac sink.
- Actuators with plenum cable do not have numbers; use color codes instead.

Meets cULus requirements without the need of an electrical ground connection.

WARNING! LIVE ELECTRICAL COMPONENTS!
 During installation, testing, servicing and troubleshooting of this product, it may be necessary to work with live electrical components. Have a qualified licensed electrician or other individual who has been properly trained in handling live electrical components perform these tasks. Failure to follow all electrical safety precautions when exposed to live electrical components could result in death or serious injury.

