

G250S-N, 2-Way, Globe Valve, Stainless Steel Trim



Technical Data

Service	chilled or hot water, up to 60% glycol, steam
Flow Characteristic	modified equal percentage
Controllable Flow Range	stem up - open A to AB
Size [mm]	2" [50]
End Fitting	NPT female ends
Body	bronze
Stem	316 stainless steel
Stem Packing	EPDM O-ring
Seat	316 stainless steel
Plug	316 stainless steel
Body Pressure Rating [psi]	ANSI 250
ANSI Class	ANSI 250 (up to 400 psi below 150°F)
Max Inlet Pressure (Steam)	100 psi (690 kPa)
Media Temperature Range (Water)	20°F to 338°F [-7°C to 170°C]
Media Temperature Range (Steam)	32°F to 338°F [0°C to 170°C]
Maximum Differential Pressure (Steam)	50 psi (345 kPa)
Max Differential Pressure (Water)	35 psi (241 kPa)
Rangeability	100:1
Cv	40
Leakage	ANSI Class VI
Servicing	repack kits available

Flow Pattern



Application

This valve is typically used in air handling units on heating or cooling coils, and fan coil unit heating or cooling coils. Some other common applications include unit ventilators, VAV box re-heat coils and bypass loops. This valve is suitable for use in hydronic systems with variable flow. Bronze and stainless steel trim valves can be used for steam applications, depending on actuator and close-off combinations.

Suitable Actuators

	Non-Spring	Spring	Electronic Fail-Safe
G250S-N	LVB(X)	NFB(X)	LVKB(X)

Dimensions (Inches [mm])

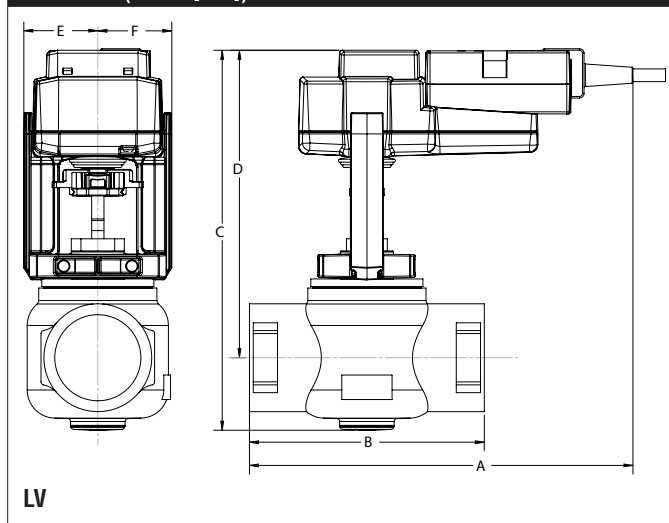

A	B	C	D	E	F
10" [254]	6.12" [156]	9.92" [252]	8.01" [203]	1.93" [49]	

Piping

The valves should be mounted in a weather-protected area in a location that is within the ambient limits of the actuator. Allow sufficient room for valve with actuator and for service. The G2 and G3 preferred mounting position of the valve is with the valve stem vertical above the valve body, for maximum life. However, the assemblies can be mounted with the valve stem vertical or horizontal in relation to the pipe. The actuators should never be mounted underneath the valve, as condensation can build up and result in a failure of the actuators.

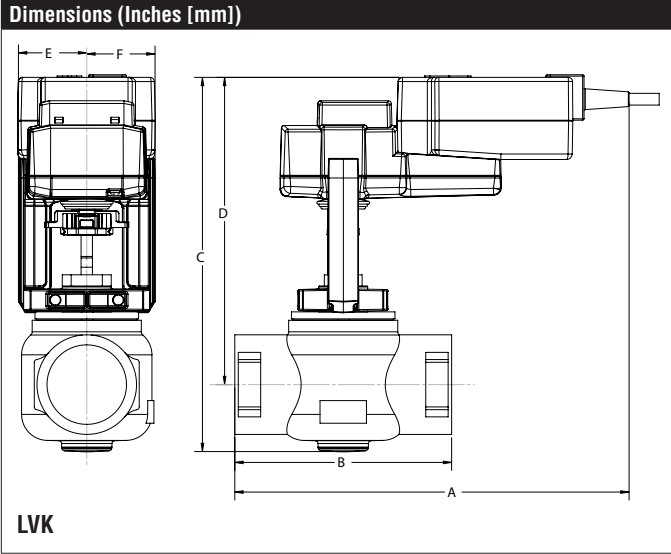

A	B	C	D	E	F
11" [279]	6.12" [156]	10.5" [267]	8.78" [223]	1.93" [49]	

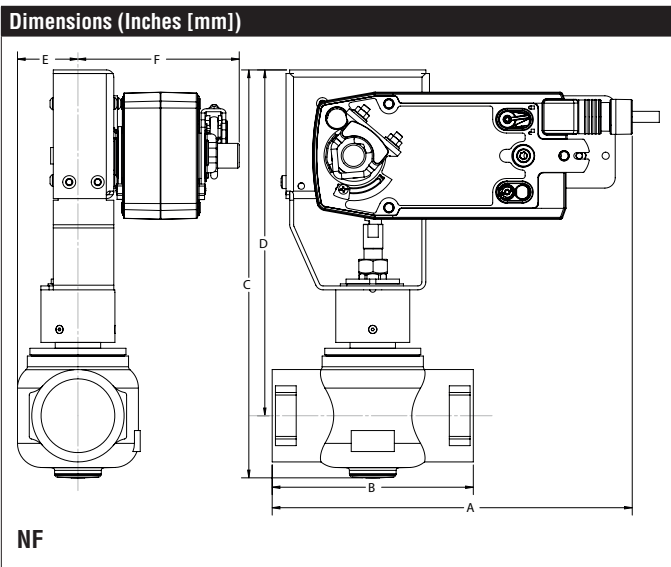

A	B	C	D	E	F
10.92" [277]	6.12" [156]	12.38" [314.4]	10.5" [267]	1.82" [46]	4.94" [125]

NFBUP-X1

On/Off, Spring Return, 24 to 240 VAC



Technical Data	
Power Supply	24...240 VAC, -20% / +10%, 50/60 Hz, 24...125 VDC, ±10%
Power Consumption Running	6 W
Power Consumption Holding	2.5 W
Transformer Sizing	6 VA @ 24 VAC (class 2 power source), 6.5 VA @ 120 VAC, 9.5 VA @ 240 VAC
Electrical Connection	3ft [1m], 18 GA appliance cable with 1/2" conduit connector
Overload Protection	electronic throughout 0° to 95° rotation
Angle of Rotation	95°
Torque motor	Min. 90 in-lbs [10 Nm]
Direction of Rotation (Motor)	reversible with CW/CCW mounting
Direction of Rotation (Fail-Safe)	reversible with CW/CCW mounting
Position Indication	visual indicator, 0° to 95° (0° is full spring return position)
Manual Override	5 mm hex crank (3/16" Allen), supplied
Running Time (Motor)	<75 sec
Running Time (Fail-Safe)	<20 sec @ -4°F to 122°F [-20°C to 50°C], <60 sec @ -22°F [-30°C]
Ambient Humidity	max. 95% RH non-condensing
Ambient Temperature Range	-22°F to 122°F [-30°C to 50°C]
Storage Temperature Range	-40°F to 176°F [-40°C to 80°C]
Housing	NEMA 2, IP54, UL Enclosure Type 2
Housing Material	zinc coated metal and plastic casing
Agency Listings†	cULus acc. to UL60730-1A/-2-14, CAN/CSA E60730-1:02, CE acc. to 2004/108/EC and 2006/95/EC
Noise Level (Motor)	≤50 dB (A)
Noise Level (Fail-Safe)	<62 dB (A)
Servicing	maintenance free
Quality Standard	ISO 9001
Weight	4.2 lb [1.9 kg]

†Rated Impulse Voltage 800V, Type of action 1.AA, Control Pollution Degree 3

Wiring Diagrams

⚠ WARNING! LIVE ELECTRICAL COMPONENTS!
During installation, testing, servicing and troubleshooting of this product, it may be necessary to work with live electrical components. Have a qualified licensed electrician or other individual who has been properly trained in handling live electrical components perform these tasks. Failure to follow all electrical safety precautions when exposed to live electrical components could result in death or serious injury.

✂ INSTALLATION NOTES

- (A)** Actuators with appliance cables are numbered.
- (UP)** Universal Power Supply (UP) models can be supplied with 24 VAC up to 240 VAC, or 24 VDC up to 125 VDC.
- 1** Provide overload protection and disconnect as required.
- ◆** Meets cULus requirements without the need of an electrical ground connection.

