

G350B-N, 3-Way, Globe Valve, Bronze Trim, Mixing/Diverting



Technical Data

Service	chilled, hot water, up to 60% glycol
Flow Characteristic	modified equal percentage, linear B to AB
Controllable Flow Range	stem up - open B to AB
Size [mm]	2" [50]
End Fitting	NPT female ends
Body	bronze
Stem	stainless steel
Stem Packing	EPDM O-ring
Seat	bronze
Plug	brass
Body Pressure Rating [psi]	ANSI 250
ANSI Class	ANSI 250 (up to 400 psi below 150°F)
Media Temperature Range (Water)	20°F to 280°F [-7°C to 138°C]
Max Differential Pressure (Water)	35 psi (241 kPa)
Rangeability	A-port 100:1, B-port 50:1
Cv	41
Leakage	ANSI Class VI
Servicing	repack kits available

Flow Pattern

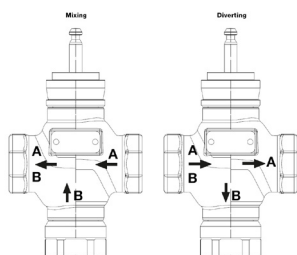

Application

This valve is typically used in Air handling units on heating or cooling coils, and fan coil unit heating or cooling coils. Some other common applications include Unit Ventilators, VAV box re-heat coils and bypass loops. This valve is suitable for use in hydronic system with constant or variable flow. These 3-way valves can be used for both Mixing and Diverting depending on the piping configuration.

Suitable Actuators

	Non-Spring	Spring	Electronic Fail-Safe
G350B-N	SVB(X)	AFB(X)	SVKB(X)

Dimensions (Inches [mm])

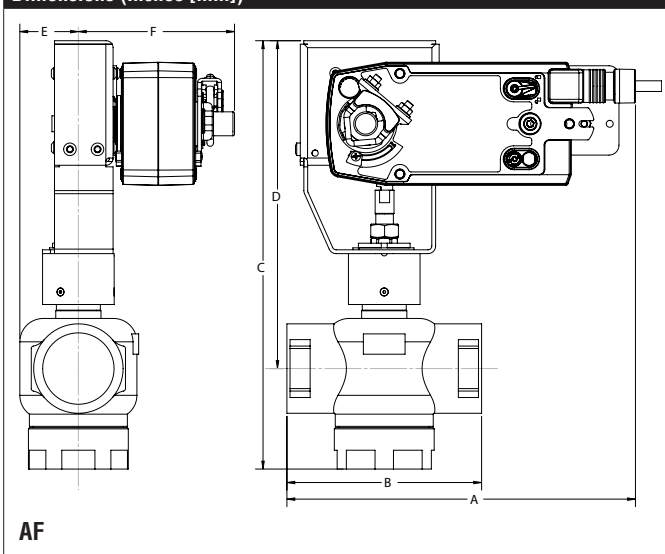

A	B	C	D	E	F
10.92" [277]	6.12" [156]	13.47" [342]	10.38" [264]	1.82" [46]	4.94" [125]

Piping

The valves should be mounted in a weather-protected area in a location that is within the ambient limits of the actuator. Allow sufficient room for valve with actuator and for service. The G2 and G3 preferred mounting position of the valve is with the valve stem vertical above the valve body, for maximum life. However, the assemblies can be mounted with the valve stem vertical or horizontal in relation to the pipe. The actuators should never be mounted underneath the valve, as condensation can build up and result in a failure of the actuators.

G350B-N, 3-Way, Globe Valve, Bronze Trim, Mixing/Diverting

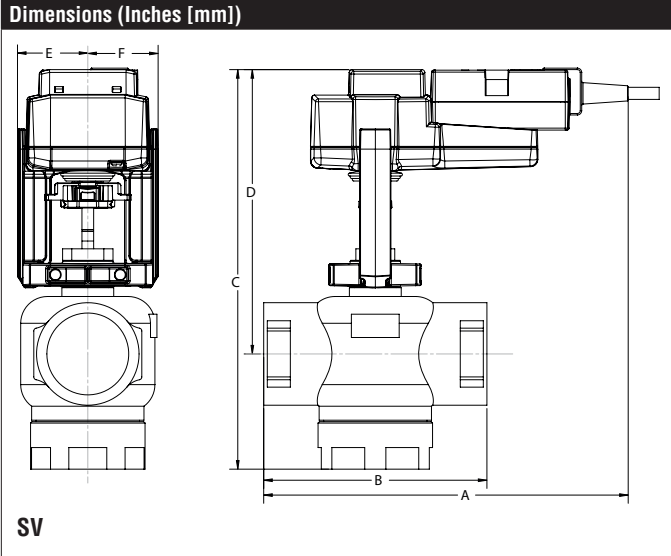

A	B	C	D	E	F
10.2" [259]	6.12" [156]	10.90" [277]	7.81" [198]	1.93" [49]	

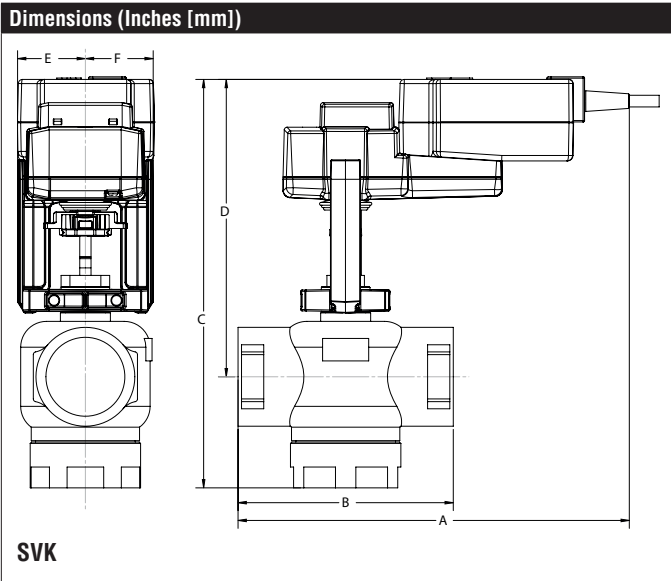

A	B	C	D	E	F
11" [279]	6.12" [156]	10.75" [273]	8.43" [214]	1.93" [49]	

AFX24-MFT-S-X1

Modulating, Spring Return, 24 V, Multi-Function Technology®



Technical Data	
Power Supply	24 VAC, ±20%, 50/60 Hz, 24 VDC, -10% / +20%
Power Consumption Running	7.5 W
Power Consumption Holding	3 W
Transformer Sizing	10 VA (class 2 power source)
Electrical Connection	(2) 3ft [1m], 10ft [3m] or 16ft [5m] 18 GA appliance cables with or without 1/2" conduit connectors
Overload Protection	electronic throughout 0° to 95° rotation
Operating Range Y	2 to 10 VDC, 4 to 20 mA w/ ZG-R01 (500 Ω, 1/4 W resistor), variable (VDC, PWM, floating point, on/off)
Feedback Output U	2 to 10 VDC, 0.5 mA max, VDC variable
Angle of Rotation	95°, adjustable with mechanical end stop, 35° to 95°
Nominal Torque	Min. 180 in-lbs [20 Nm]
Direction of Rotation (Motor)	reversible with built-in switch
Direction of Rotation (Fail-Safe)	reversible with CW/CCW mounting
Position Indication	visual indicator, 0° to 95° (0° is full spring return position)
Manual Override	5 mm hex crank (3/16" Allen), supplied
Running Time (Motor)	default 150 sec, variable 70...220 sec
Running Time (Fail-Safe)	<20 sec
Override Control	min. position = 0% , mid. Position = 50% , max. position = 100% (Default)
Ambient Humidity	max. 95% RH non-condensing
Ambient Temperature Range	-22°F to 122°F [-30°C to 50°C]
Storage Temperature Range	-40°F to 176°F [-40°C to 80°C]
Housing	NEMA 2, IP54, UL Enclosure Type 2
Housing Material	zinc coated metal and plastic casing
Agency Listings†	cULus acc. to UL60730-1A/-2-14, CAN/CSA E60730-1:02, CE acc. to 2004/108/EC
Noise Level (Motor)	<40 dB (A)
Noise Level (Fail-Safe)	<62 dB (A)
Servicing	maintenance free
Quality Standard	ISO 9001
Weight	4.6 lb [2.1 kg]
Auxiliary switch	2 x SPDT, 3A resistive (0.5A inductive) @ 250 VAC, one set at 10°, one adjustable 10° to 90°
Degree of Protection IEC/EN	IP54

*Variable when configured with MFT options.

†Rated Impulse Voltage 800V, Type of Action 1.AA.B, Control Pollution Degree 3.

Date created, 02/12/2018 - Subject to change. © Belimo Aircontrols (USA), Inc.

Wiring Diagrams

⚠ WARNING! LIVE ELECTRICAL COMPONENTS!
 During installation, testing, servicing and troubleshooting of this product, it may be necessary to work with live electrical components. Have a qualified licensed electrician or other individual who has been properly trained in handling live electrical components perform these tasks. Failure to follow all electrical safety precautions when exposed to live electrical components could result in death or serious injury.

◆ Meets cULus requirements without the need of an electrical ground connection.

Ⓐ Actuators with appliance cables are numbered.

⚡ Apply only AC line voltage or only UL-Class 2 voltage to the terminals of auxiliary switches. Mixed or combined operation of line voltage/safety extra low voltage is not allowed.

1 Provide overload protection and disconnect as required.

3 Actuators may also be powered by 24 VDC.

4 Two built-in auxiliary switches (2x SPDT), for end position indication, interlock control, fan startup, etc.

5 Only connect common to negative (-) leg of control circuits.

7 A 500 Ω resistor (ZG-R01) converts the 4 to 20 mA control signal to 2 to 10 VDC.

8 Control signal may be pulsed from either the Hot (Source) or Common (Sink) 24 VAC line.

10 For triac sink the Common connection from the actuator must be connected to the Hot connection of the controller. Position feedback cannot be used with a triac sink controller; the actuator internal common reference is not compatible.

12 IN4004 or IN4007 diode. (IN4007 supplied, Belimo part number 40155).

46 Actuators may be controlled in parallel. Current draw and input impedance must be observed.

47 Master-Slave wiring required for piggy-back applications. Feedback from Master to control input(s) of Slave(s).

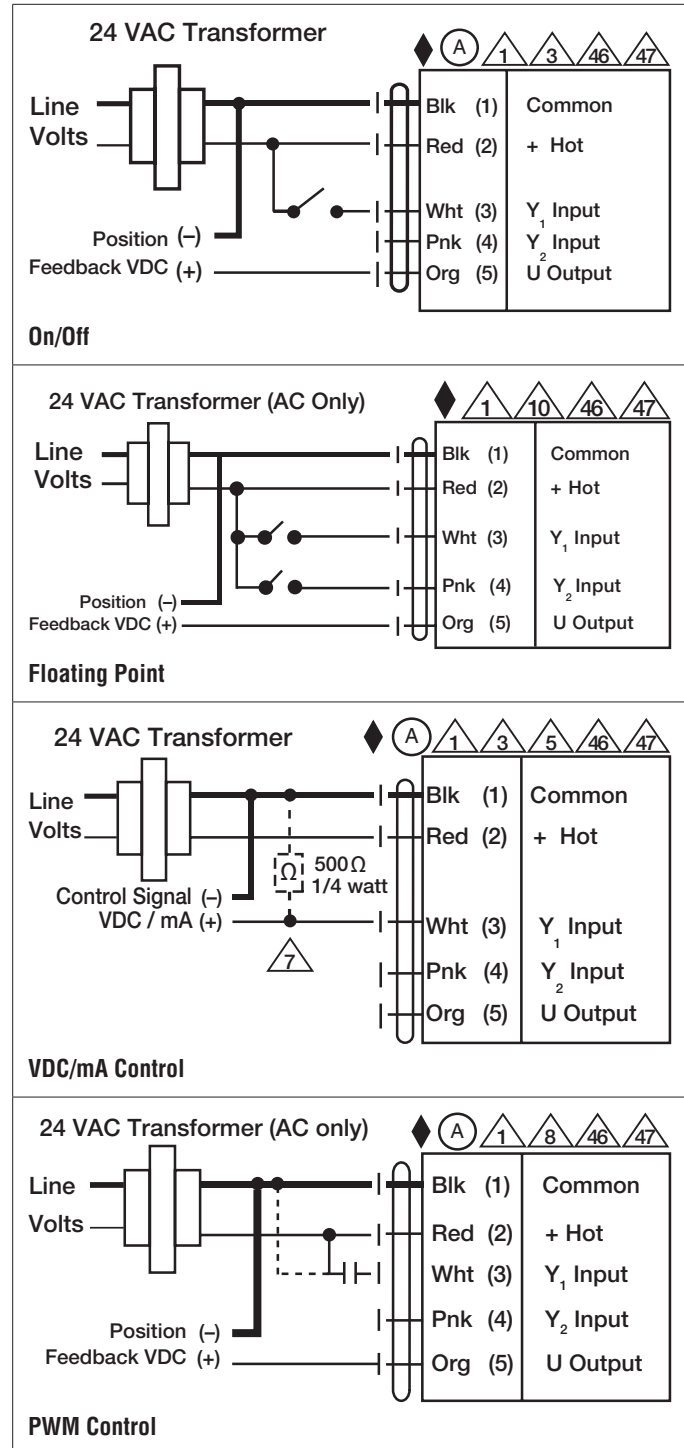

Date created, 02/12/2018 - Subject to change. © Belimo Aircontrols (USA), Inc.

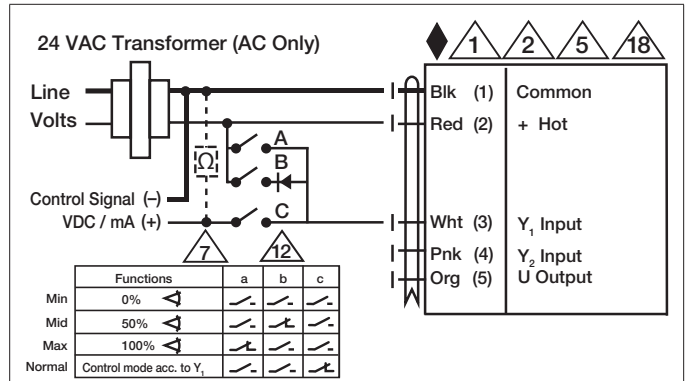

Override Control

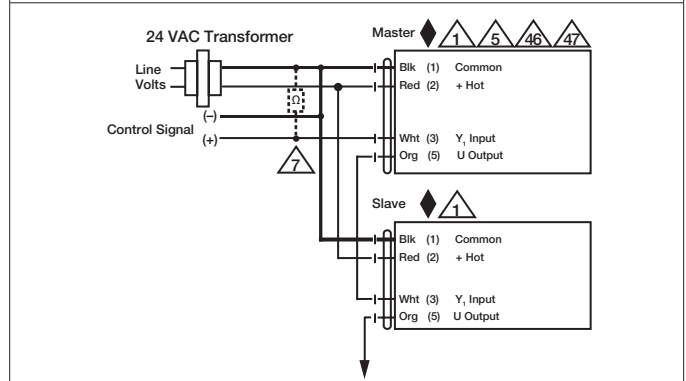

Master - Slave

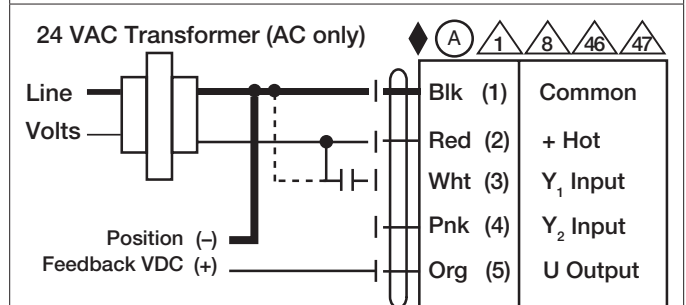

PWM Control

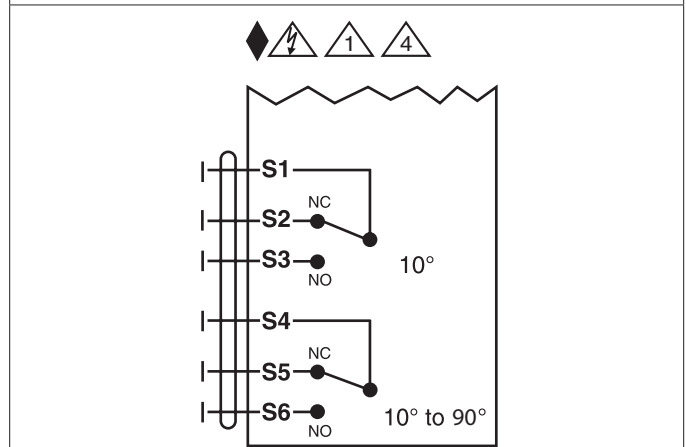

Auxiliary Switches