

# G6100C-250, 2-Way, Pressure Compensated Flanged Globe Valve

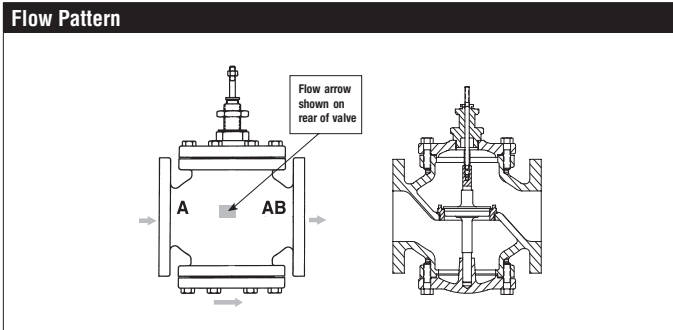

Technical Data	
Service	chilled or hot water, up to 60% glycol, steam
Flow Characteristic	equal percentage
Controllable Flow Range	stem up - open A to AB
Size [mm]	4" [100]
End Fitting	250 lb. flanged
Body	Cast Iron - ASTM A126 Class B
Stem	stainless steel
Stem Packing	NLP EPDM (no lip packing)
Seat	316 stainless steel
Plug	bronze
Body Pressure Rating [psi]	ANSI 250
ANSI Class	ANSI 250 ( up to 280 psi below 350°F)
Number of Bolt Holes	8
Max Inlet Pressure (Water)	250 psi (1724 kPa) @ 300°F [149°C]
Max Inlet Pressure (Steam)	35 psi (241 kPa)
Media Temperature Range (Water)	32°F to 350°F [0°C to 176°C]
Media Temperature Range (Steam)	32°F to 280°F [0°C to 138°C]
Maximum Differential Pressure (Steam)	15 psi (103 kPa)
Max Differential Pressure (Water)	25 psi (172 kPa)
Rangeability	98:1
Cv	170
Weight	125 lb [56.7 kg]
Leakage	ANSI Class III
Servicing	Repack/Rebuild kits available



## Application

This valve is typically used in large air handling units on heating or cooling coils. This valve is suitable for use in a hydronic system with variable flow. Bronze or stainless steel trim valves can be used for steam applications, depending on actuator and close-off combination.

## Suitable Actuators

	Non-Spring	Spring	Electronic Fail-Safe
G6100C-250	EVB(X)	2*AFB(X)	AVKB(X)

## Dimensions (Inches [mm])

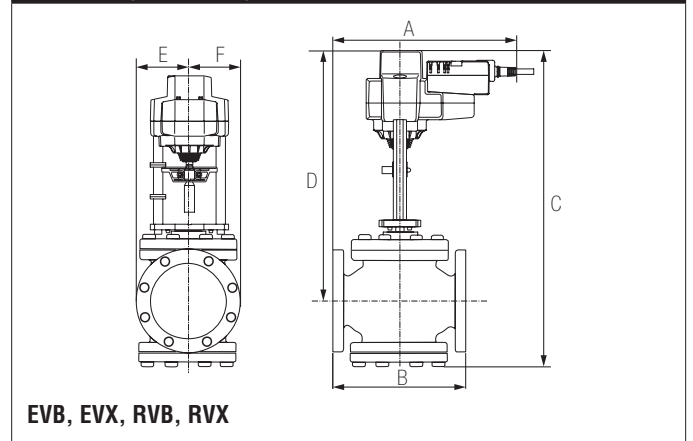

A	B	C	D	E	F
13.98" [355]	13.62" [346]	26.64" [676]	19.75" [502]	5" [127]	

## Piping

The valves should be mounted in a weather-protected area in a location that is within the ambient limits of the actuator. Allow sufficient room for valve with actuator and for service. The preferred mounting position of the valve is with the valve stem vertical above the valve body, for maximum life. However, the assemblies can be mounted with valve stem vertical above the valve or up to 45 degrees in relation to the horizontal pipe. The actuators should never be mounted underneath the valve, as condensation can build up and result in a failure of the actuators. Do not reverse flow direction.

## Dimensions (Inches [mm])

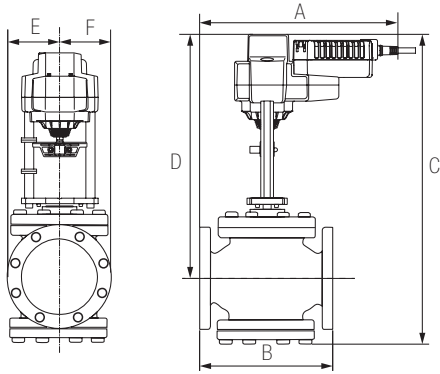

AVKB, AVKX

A	B	C	D	E	F
13.98" [355]	13.62" [346]	24.64" [626]	19.75" [502]	5" [127]	

## Dimensions (Inches [mm])

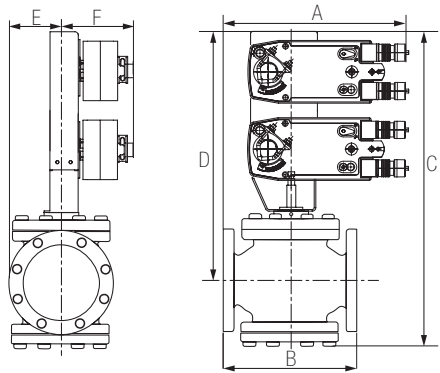

2\*AFB, 2\*AFX

A	B	C	D	E	F
12" [304]	13.62" [346]	30" [762]	23.25" [590]	3.75" [95]	5.25" [135]

# EVX120-3

On/Off, Floating Point, Non-Spring Return, Linear, 100 to 240 VAC



Technical Data	
Power Supply	100-240 VAC ± 20%, 50/60 Hz
Power Consumption Running	5 W
Power Consumption Holding	1.5 W
Transformer Sizing	7.5 VA (class 2 power source)
Electrical Connection	3 ft, 18 GA appliance rated cable with 1/2" conduit connector protected NEMA 2 (IP54)
Overload Protection	electronic throughout full stroke
Electrical Protection	actuators are double insulated
Operating Range Y	on/off, floating point
Input Impedance	100 k Ω (0.1 mA), 500 Ω, 1000 Ω (on/off)
Feedback Output U	No Feedback
Stroke	2" [50 mm]
Linear Force	562 lbf [2500 N force]
Direction of Rotation (Motor)	reversible with built-in switch
Position Indication	stroke indicator on bracket
Manual Override	5 mm hex crank (3/16" Allen), supplied
Running Time (Motor)	90 sec (default), Optional (90 or 150 sec)
Humidity	5 to 95% RH non-condensing
Ambient Temperature Range	-22°F to 122°F [-30°C to 50°C]
Storage Temperature Range	-40°F to 176°F [-40°C to 80°C]
Housing	NEMA 2, IP54, UL enclosure type 2
Housing Material	Aluminum die cast and plastic casing
Agency Listings†	cULus acc. to UL60730-1A/-2-14, CAN/CSA E60730-1:02, CE acc. to 2004/108/EC and 2006/95/EC
Noise Level (Motor)	<60 dB (A)
Servicing	maintenance free
Quality Standard	ISO 9001
Weight	5.7 lb [2.6 kg]

† Use flexible metal conduit. Push the listed conduit fitting device over the actuator's cable to butt against the enclosure. Screw in conduit connector. Jacket the actuators input wiring with listed flexible conduit. Properly terminate the conduit in a suitable junction box. Rated impulse Voltage 800V. Type of action 1. Control pollution degree 3.

Date created, 11/03/2016 - Subject to change. © Belimo Aircontrols (USA), Inc.

**Wiring Diagrams**

**INSTALLATION NOTES**

- Actuators with appliance cables are numbered.
- Actuators may be connected in parallel. Power consumption and input impedance must be observed.
- Meets cULus requirements without the need of an electrical ground connection.
- WARNING! LIVE ELECTRICAL COMPONENTS!** During installation, testing, servicing and troubleshooting of this product, it may be necessary to work with live electrical components. Have a qualified licensed electrician or other individual who has been properly trained in handling live electrical components perform these tasks. Failure to follow all electrical safety precautions when exposed to live electrical components could result in death or serious injury.

