

G680LCS, 2-Way, Pressure Compensated Flanged Globe Valve



Technical Data

Service	chilled or hot water, up to 60% glycol, steam
Flow Characteristic	linear
Controllable Flow Range	stem up - open A to AB
Size [mm]	3" [80]
End Fitting	125 lb flanged
Body	cast iron - ASTM A126 Class B (ASME B16.1)
Stem	316 stainless steel
Stem Packing	NLP EPDM (no lip packing)
Seat	316 stainless steel
Plug	stainless steel
Body Pressure Rating [psi]	ANSI 125
ANSI Class	ANSI 125 (up to 175 psi below 150°F)
Number of Bolt Holes	4
Max Inlet Pressure (Water)	150 psi (1034 kPa) @ 250°F
Max Inlet Pressure (Steam)	100 psi (690 kPa)
Media Temperature Range (Water)	32°F to 350°F [0°C to 176°C]
Media Temperature Range (Steam)	32°F to 338°F [0°C to 170°C]
Maximum Differential Pressure (Steam)	50 psi (345 kPa)
Max Differential Pressure (Water)	50 psi (345 kPa)
Rangeability	91:1
Cv	90
Weight	75 lb [34 kg]
Leakage	ANSI Class III
Servicing	Repack/Rebuild kits available

Flow Pattern

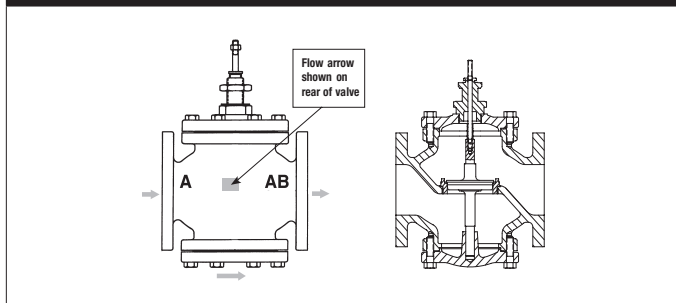

Application

This valve is typically used in large air handling units on heating or cooling coils. This valve is suitable for use in a hydronic system with variable flow. Bronze or stainless steel trim valves can be used for steam applications, depending on actuator and close-off combination.

Suitable Actuators

	Non-Spring	Spring	Electronic Fail-Safe
G680LCS	EVB(X)	AFB(X)	AVKB(X)

Dimensions (Inches [mm])

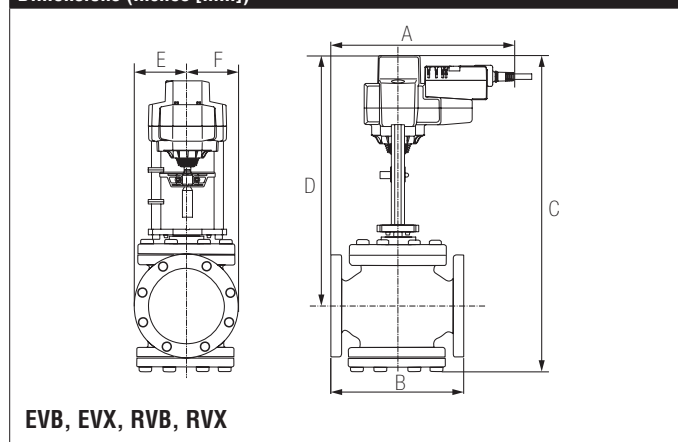

A	B	C	D	E	F
12.2" [310]	10" [254]	24.64" [626]	19.25" [489]	3.94" [100]	

Piping

The valves should be mounted in a weather-protected area in a location that is within the ambient limits of the actuator. Allow sufficient room for valve with actuator and for service. The preferred mounting position of the valve is with the valve stem vertical above the valve body, for maximum life. However, the assemblies can be mounted with valve stem vertical above the valve or up to 45 degrees in relation to the horizontal pipe. The actuators should never be mounted underneath the valve, as condensation can build up and result in a failure of the actuators. Do not reverse flow direction.

G680LCS, 2-Way, Pressure Compensated Flanged Globe Valve

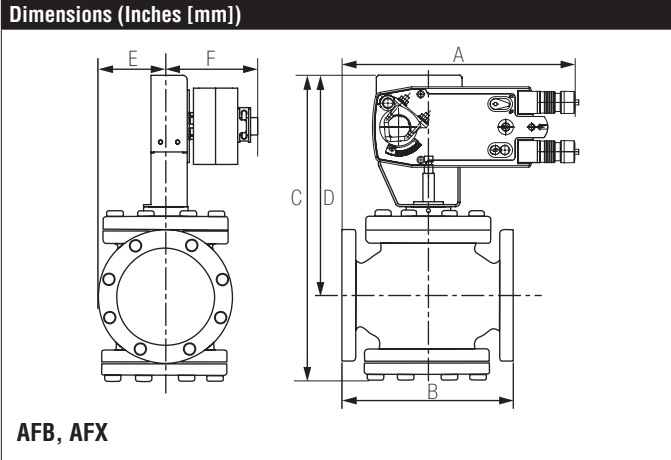

A	B	C	D	E	F
12.2" [310]	10" [254]	22.77" [577]	17.85" [453]	3.94" [100]	5.25" [135]

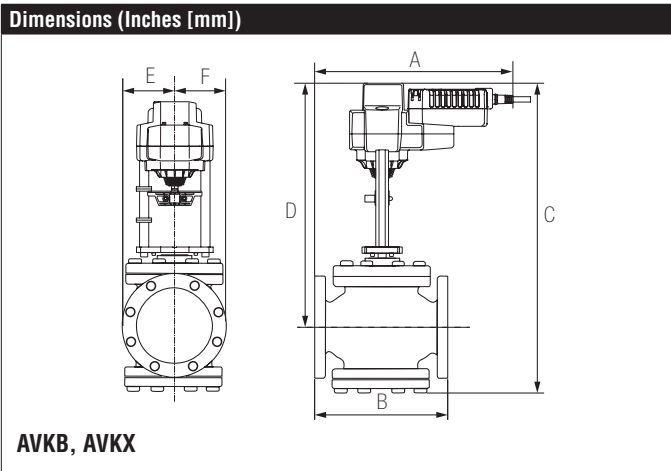

A	B	C	D	E	F
12.2" [310]	10" [254]	24.64" [626]	19.25" [489]	3.94" [100]	

AFX24-MFT-X1

Modulating, Spring Return, 24 V, Multi-Function Technology®



Technical Data	
Power Supply	24 VAC±20%, 50/60Hz, 24 VDC+20%/-10%
Power Consumption Running	7.5 W
Power Consumption Holding	3 W
Transformer Sizing	10 VA (class 2 power source)
Electrical Connection	18 GA appliance rated cable with 1/2" conduit connector protected NEMA 2 (IP54) 3 ft [1m] 10 ft [3m] and 16 ft [5m]
Overload Protection	electronic throughout 0° to 95° rotation
Operating Range Y	2 to 10 VDC, 4 to 20 mA w/ ZG-R01 (500 Ω, 1/4 W resistor), variable (VDC, PWM, floating point, on/off)
Feedback Output U	2 to 10 VDC, 0.5 mA max, VDC variable
Angle of Rotation	95° (adjustable with mechanical end stop, 35° to 95°)
Direction of Rotation (Motor)	reversible with built-in switch
Direction of Rotation (Fail-Safe)	reversible with CW/CCW mounting
Position Indication	visual indicator, 0° to 95° (0° is full spring return position)
Manual Override	5 mm hex crank (3/16" Allen), supplied
Running Time (Motor)	150 sec (default), variable (70 to 220 sec)
Running Time (Fail-Safe)	<20 sec
Override Control	min. position = 0% , mid. Position = 50% , max. position = 100% (Default)
Humidity	max. 95% RH non-condensing
Ambient Temperature Range	-22°F to +122°F [-30°C to +50°C]
Storage Temperature Range	-40°F to +176°F [-40°C to +80°C]
Housing	NEMA 2, IP54, UL enclosure type 2
Housing Material	zinc coated metal and plastic casing
Agency Listings†	cULus acc. to UL60730-1A/-2-14, CAN/CSA E60730-1:02, CE acc. to 2004/108/EC
Noise Level (Motor)	<40 dB (A)
Noise Level (Fail-Safe)	<62 dB (A)
Servicing	maintenance free
Quality Standard	ISO 9001
Weight	4.6 lb [2.1 kg]

*Variable when configured with MFT options.

†Rated Impulse Voltage 800V, Type of action 1.AA, Control Pollution Degree 3

Date created, 09/01/2016 - Subject to change. © Belimo Aircontrols (USA), Inc.

Wiring Diagrams

⚠ WARNING! LIVE ELECTRICAL COMPONENTS!
 During installation, testing, servicing and troubleshooting of this product, it may be necessary to work with live electrical components. Have a qualified licensed electrician or other individual who has been properly trained in handling live electrical components perform these tasks. Failure to follow all electrical safety precautions when exposed to live electrical components could result in death or serious injury.

◆ Meets cULus requirements without the need of an electrical ground connection.

Ⓐ Actuators with appliance cables are numbered.

1 Provide overload protection and disconnect as required.

3 Actuators may also be powered by 24 VDC.

5 Only connect common to negative (-) leg of control circuits.

7 A 500 Ω resistor (ZG-R01) converts the 4 to 20 mA control signal to 10 VDC.

8 Control signal may be pulsed from either the Hot (Source) or Common (Sink) 24 VAC line.

10 For triac sink the Common connection from the actuator must be connected to the Hot connection of the controller. Position feedback cannot be used with a triac sink controller; the actuator internal common reference is not compatible.

12 IN4004 or IN4007 diode. (IN4007 supplied, Belimo part number 40155).

46 Actuators may be controlled in parallel. Current draw and input impedance must be observed.

47 Master-Slave wiring required for piggy-back applications. Feedback from Master to control input(s) of Slave(s).

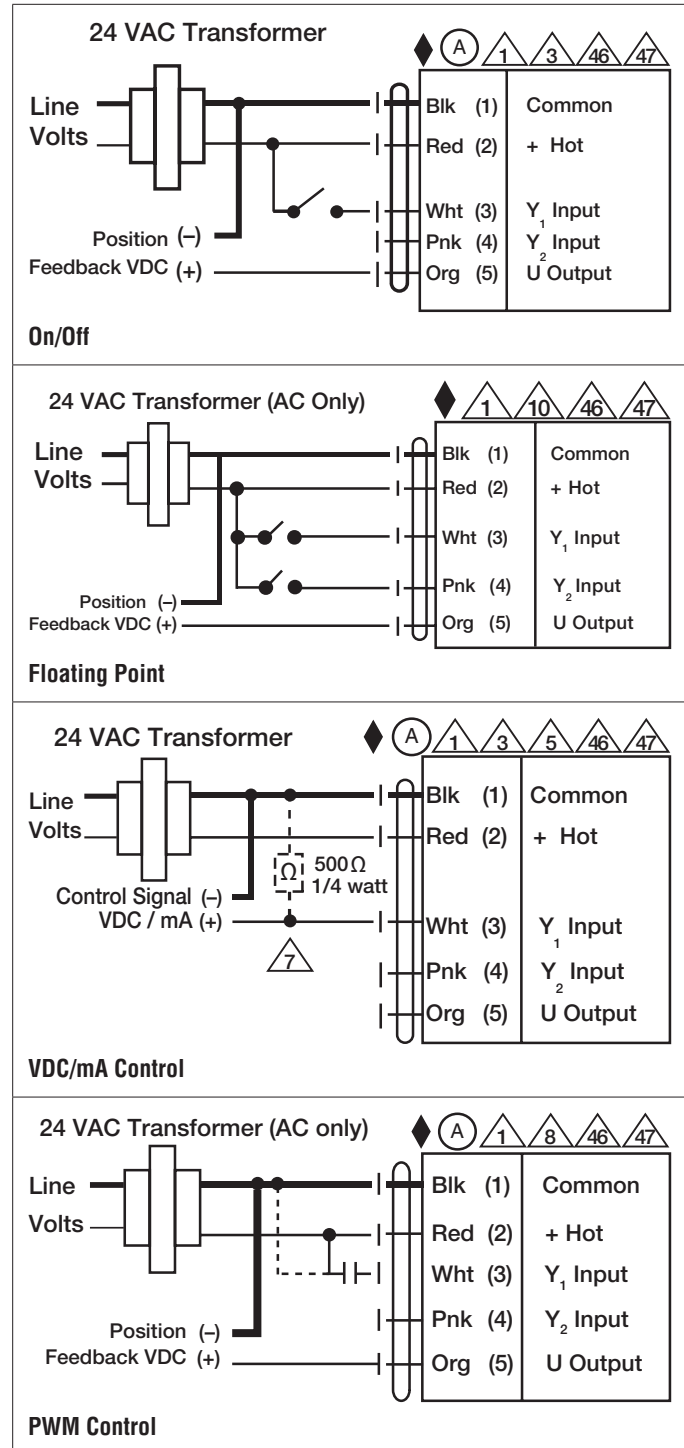

AFX24-MFT-X1

Modulating, Spring Return, 24 V, Multi-Function Technology®

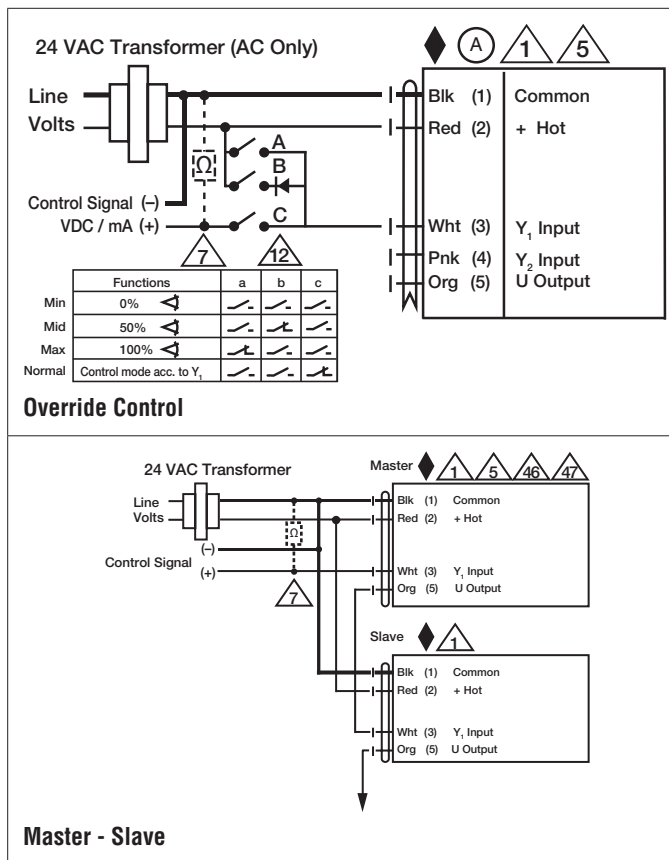

Date created, 09/01/2016 - Subject to change. © Belimo Aircontrols (USA), Inc.