

# G780S-250, 3-Way, Mixing, ANSI 250, Flanged, Stainless Steel Trim

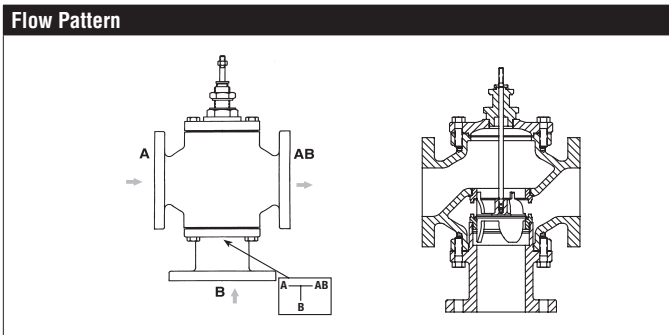

Technical Data	
Service	chilled, hot water, up to 60% glycol
Flow Characteristic	linear
Controllable Flow Range	stem up - open B to AB
Size [mm]	3" [80]
End Fitting	250 lb flanged
Body	cast iron - ASTM A126 Class B (ASME B16.1)
Stem	316 stainless steel
Stem Packing	NLP EPDM (no lip packing)
Seat	316 stainless steel
Plug	stainless steel
Body Pressure Rating [psi]	ANSI 250
ANSI Class	ANSI 250 (up to 280 psi below 350°F)
Number of Bolt Holes	8
Max Inlet Pressure (Water)	250 psi (1724 kPa) @ 350°F
Media Temperature Range (Water)	32°F to 350°F [0°C to 176°C]
Max Differential Pressure (Water)	50 psi (345 kPa)
Rangeability	50:1
Cv	85
Weight	91.9 lb [41.7 kg]
Leakage	ANSI Class III
Servicing	Repack/Rebuild kits available



## Application

This valve is typically used in large air handling units on heating or cooling coils. This valve is suitable for use in a hydronic system with variable flow. Valves are designed for ANSI 250 piping systems

## Suitable Actuators

	Non-Spring	Spring	Electronic Fail-Safe
G780S-250	EVB(X), RVB(X)	AFB(X), 2*AFB(X)	AVKB(X), 2*GKB(X)

## Dimensions (Inches [mm])

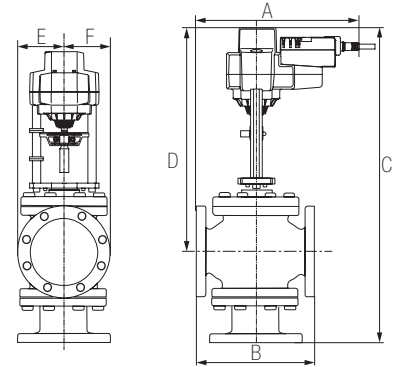

## EVB, EVX, RVB, RVX

A	B	C	D	E	F
12.6" [320]	10.75" [273]	27.27" [693]	19" [483]	4.12" [105]	

## Piping

The valves should be mounted in a weather-protected area in a location that is within the ambient limits of the actuator. Allow sufficient room for valve with actuator and for service. The preferred mounting position of the valve is with the valve stem vertical above the valve body, for maximum life. However, the assemblies can be mounted with valve stem vertical above the valve or up to 45 degrees in relation to the horizontal pipe. The actuators should never be mounted underneath the valve, as condensation can build up and result in a failure of the actuators. Do not reverse flow direction.

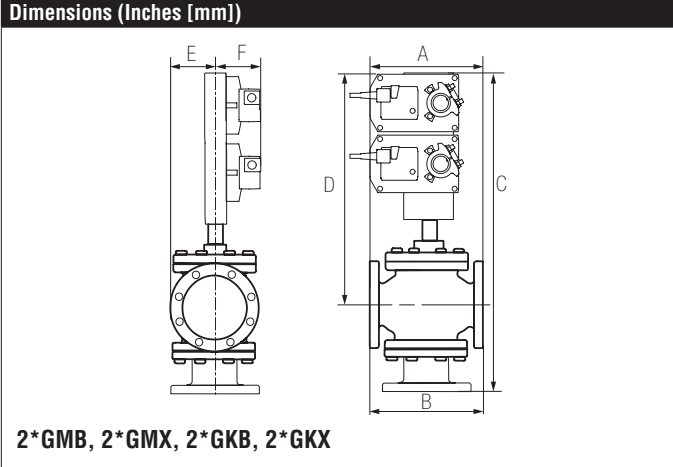

A	B	C	D	E	F
12.75" [323]	10.75" [273]	30.53" [775]	22.5" [572]	4.12" [105]	5.25" [135]

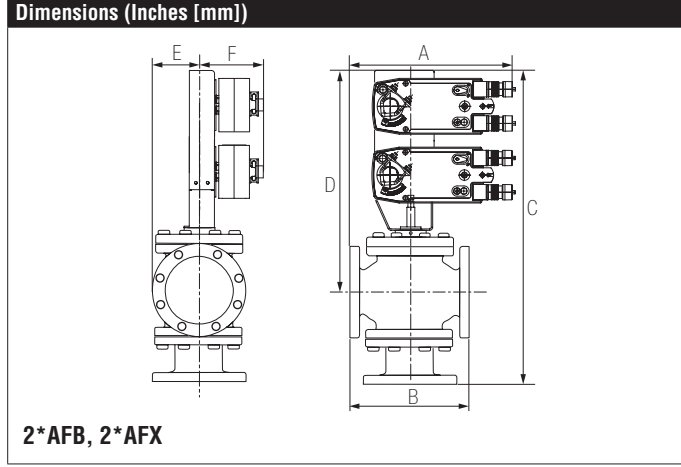

A	B	C	D	E	F
12.75" [323]	10.75" [273]	30.53" [775]	22.5" [572]	4.12" [105]	5.25" [135]

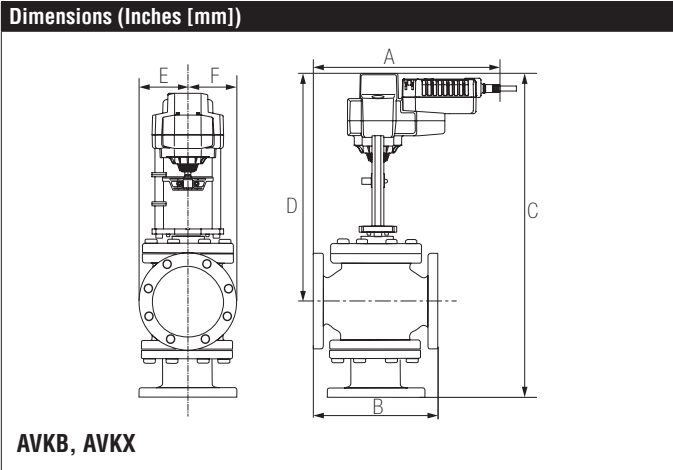

A	B	C	D	E	F
12.6" [320]	10.75" [273]	27.27" [693]	19" [483]	4.12" [105]	

# G780S-250, 3-Way, Mixing, ANSI 250, Flanged, Stainless Steel Trim

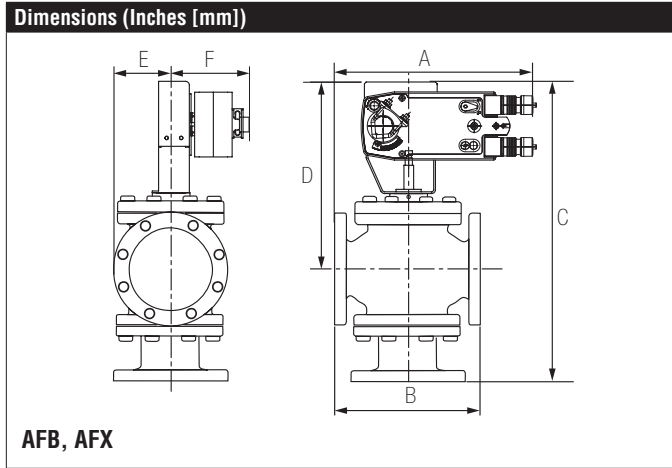

A	B	C	D	E	F
12.75" [323]	10.75" [273]	25.6" [650]	17.5" [445]	4.12" [105]	5.25" [135]

# EVB24-MFT

Modulating, Non-Spring Return, Linear, 24 V, Multi-Function Technology®



Technical Data	
Power Supply	24 VAC, ±20%, 50/60 Hz, 24 VDC, ±10%
Power Consumption Running	5 W
Power Consumption Holding	1.5 W
Transformer Sizing	7.5 VA (class 2 power source)
Electrical Connection	3ft [1m], 18 GA plenum rated cable with 1/2" conduit connector protected NEMA 2 (IP54)
Overload Protection	electronic throughout full stroke
Electrical Protection	actuators are double insulated
Operating Range Y	2 to 10 VDC, 4 to 20 mA w/ ZG-R01 (500 Ω, 1/4 W resistor), variable (VDC, PWM, floating point, on/off)
Input Impedance	100 k Ω for 2 to 10 VDC (0.1 mA), 500 Ω for 4 to 20 mA, 1500 Ω for PWM, floating point and On/Off
Feedback Output U	2 to 10 VDC
Stroke	0.75" [19 mm]
Actuating force motor	562 lbf [2500 N]
Direction of Rotation (Motor)	reversible with built-in switch
Position Indication	stroke indicator on bracket
Manual Override	5 mm hex crank (3/16" Allen), supplied
Running Time (Motor)	default 90 sec, variable 90...150 sec
Ambient Humidity	5 to 95% RH non-condensing
Ambient Temperature Range	-22°F to 122°F [-30°C to 50°C]
Storage Temperature Range	-40°F to 176°F [-40°C to 80°C]
Housing	NEMA 1, IP54, UL Enclosure Type 1
Housing Material	Aluminum die cast and plastic casing
Agency Listings†	cULus acc. to UL60730-1A/-2-14, CAN/CSA E60730-1:02, CE acc. to 2004/108/EC and 2006/95/EC
Noise Level (Motor)	<60 dB (A)
Servicing	maintenance free
Quality Standard	ISO 9001
Weight	5.7 lb [2.6 kg]
Degree of Protection IEC/EN	IP54

† Use flexible metal conduit. Push the listed conduit fitting device over the actuator's cable to butt against the enclosure. Screw in conduit connector. Jacket the actuators input wiring with listed flexible conduit. Properly terminate the conduit in a suitable junction box. Rated impulse Voltage 800V. Type of action 1. Control pollution degree 3.

Date created, 02/23/2018 - Subject to change. © Belimo Aircontrols (USA), Inc.

**Wiring Diagrams**
**INSTALLATION NOTES**

- Actuators may be connected in parallel. Power consumption and input impedance must be observed.
- Actuators may also be powered by 24 VDC.
- A 500 Ω resistor (ZG-R01) converts the 4 to 20 mA control signal to 2 to 10 VDC.
- Control signal may be pulsed from either the Hot (Source) or Common (Sink) 24 VAC line.
- For triac sink the common connection from the actuator must be connected to the hot connection of the controller. Contact closures A & B also can be triacs. A & B should both be closed for the triac source and open for triac sink.
- For triac sink the Common connection from the actuator must be connected to the Hot connection of the controller. Position feedback cannot be used with a triac sink controller; the actuator internal common reference is not compatible.
- IN4004 or IN4007 diode. (IN4007 supplied, Belimo part number 40155).
- Actuators with plenum cable do not have numbers; use color codes instead.
- Meets cULus requirements without the need of an electrical ground connection.

**WARNING! LIVE ELECTRICAL COMPONENTS!**  
 During installation, testing, servicing and troubleshooting of this product, it may be necessary to work with live electrical components. Have a qualified licensed electrician or other individual who has been properly trained in handling live electrical components perform these tasks. Failure to follow all electrical safety precautions when exposed to live electrical components could result in death or serious injury.

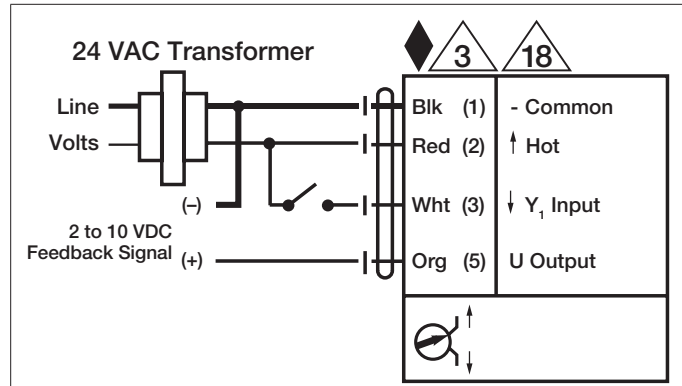
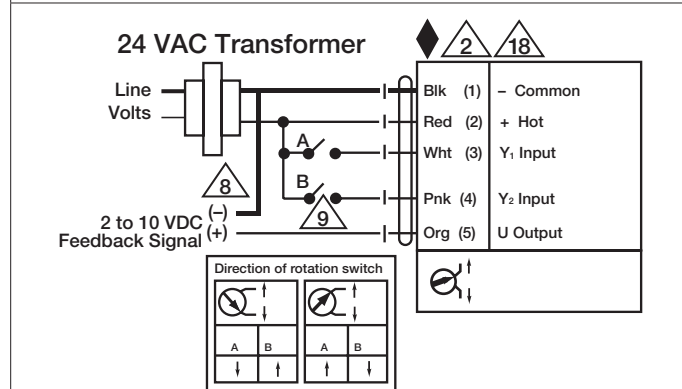
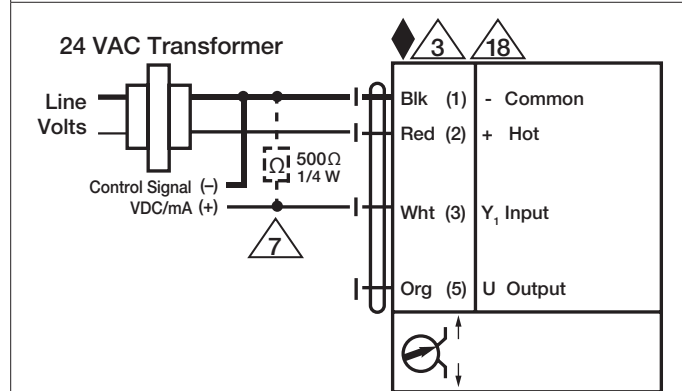
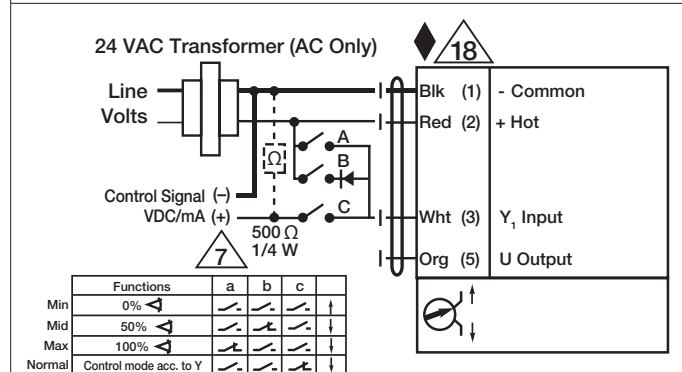
**On/Off**

**Floating Point**

**VDC / 4 to 20 mA**

**Override Control Min, Mid, Max Positions**

Functions	a	b	c
Min	0% ←	↘	↘
Mid	50% ←	↘	↘
Max	100% ←	↘	↘
Normal	Control mode acc. to Y	↘	↘