

# GKX24-MFT - Damper Actuator

Modulating, Electronic Fail-Safe, 24 V, Multi-Function Technology®



Technical Data	
Power Supply	24 VAC, ±20%, 50/60 Hz, 24 VDC, ±10%
Power Consumption Running	11 W
Power Consumption Holding	3 W
Transformer Sizing	21 VA (class 2 power source)
Shaft Diameter	1/2" to 1.05" round, centers on 3/4" with insert, 1.05" without insert
Electrical Connection	3ft [1m], 10ft [3m] or 16ft [5m] 18 GA appliance or plenum cables, with or without 1/2" conduit connector
Overload Protection	electronic throughout 0° to 95° rotation
Electrical Protection	actuators are double insulated
Operating Range Y	2 to 10 VDC, 4 to 20 mA w/ ZG-R01 (500 Ω, 1/4 W resistor), variable (VDC, PWM, floating point, on/off)
Input Impedance	100 k Ω for 2 to 10 VDC (0.1 mA), 500 Ω for 4 to 20 mA, 1500 Ω for PWM, floating point and On/Off
Feedback Output U	2 to 10 VDC, 0.5 mA max, VDC variable
Angle of Rotation	Max. 95°, adjustable with mechanical stop
Nominal Torque	Min. 360 in-lbs [40 Nm]
Direction of Rotation (Motor)	reversible with built-in switch
Direction of Rotation (Fail-Safe)	reversible with switch
Fail-Safe Position	adjustable with dial or tool 0 to 100% in 10% increments
Position Indication	reflective visual indicator (snap on)
Manual Override	external push button
Running Time (Motor)	default 150 sec, variable 90...150 sec
Running Time (Fail-Safe)	<35 sec
Bridge Time	programmable 0 to 10 sec (2 sec default) delay before fail-safe activates
Pre-charging Time	5 to 26 seconds
Angle of Rotation Adaptation	off (default)
Override Control	min. position = 0% , mid. Position = 50% , max. position = 100% (Default)
Ambient Humidity	max. 95% RH non-condensing
Ambient Temperature Range	-22°F to 122°F [-30°C to 50°C]
Storage Temperature Range	-40°F to 176°F [-40°C to 80°C]
Housing	NEMA 2, IP54, UL Enclosure Type 2
Housing Material	UL94-5VA
Agency Listings†	cULus acc. to UL60730-1A/-2-14, CAN/CSA E60730-1-02, CE acc. to 2004/108/EC
Noise Level (Motor)	≤53 dB (A)
Noise Level (Fail-Safe)	≤61 dB (A)
Servicing	maintenance free
Quality Standard	ISO 9001
Weight	4 lb [1.8 kg]
Degree of Protection IEC/EN	IP54

**Torque min. 360 in-lb, for control of damper surfaces up to 90 sq. ft.**

## Application

For fail-safe, modulating control of dampers in HVAC systems. Actuator sizing should be done in accordance with the damper manufacturer's specifications. A feedback signal is provided for position indication or master-slave applications. Maximum of two GK's can be piggybacked for torque loads of up to 720 in-lbs. Minimum 1" diameter shaft and Master-Slave wiring.

## Default/Configuration

Default parameters for 2 to 10 VDC applications of the GK..MFT actuator are assigned during manufacturing. If required, custom versions of the actuator can be ordered. The parameters are variable and can be changed by three means: Factory pre-set or custom configuration, set by the customer using PC-Tool software or the handheld ZTH US.

## Operation

The GK..24-MFT provides 95° of rotation and a visual indicator shows the position of the actuator. When reaching the damper or actuator end position the actuator automatically stops. The gear can be manually disengaged by pressing the button located on the actuator cover. The GK..24-MFT actuator uses a brushless DC motor, which is controlled by an Application Specific Integrated Circuit (ASIC). The ASIC monitors and controls the actuators rotation and provides a digital rotation sensing (DRS) function to prevent damage to the actuator in a stall condition. Power consumption is reduced in a holding mode. The actuator is electronically protected against overload. The anti-rotation strap supplied with the actuator will prevent lateral movement. Add-on auxiliary switches or feedback potentiometers are easily fastened directly onto the actuator body for signaling and switching functions.

## Fail-Safe Indication

LED status indicator lights sequence:

Yellow off / Green on: operation ok, no faults

Yellow off / Green blinking: fail-safe mechanism is active

Yellow on / Green off: fault is detected

Yellow off / Green off: not in operation / capacitors charging

Yellow on / Green on: adaption running

Yellow blinking / Green on: communication with programming tool

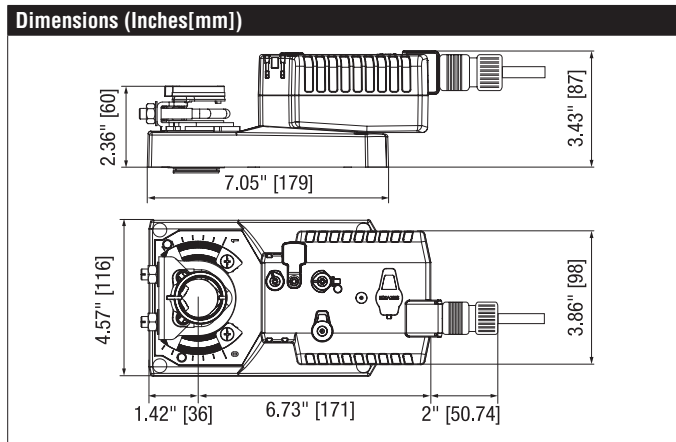

Date created, 02/12/2018 - Subject to change. © Belimo Aircontrols (USA), Inc.

\*Variable when configured with MFT options.

†Rated Impulse Voltage 800V, Type of action 1.AA, Control Pollution Degree 3



# GKX24-MFT - Damper Actuator

Modulating, Electronic Fail-Safe, 24 V, Multi-Function Technology®

Degree of Protection IEC/EN | IP54

---

\*Variable when configured with MFT options.

†Rated Impulse Voltage 800V, Type of action 1.AA, Control Pollution Degree 3

Date created, 02/12/2018 - Subject to change. © Belimo Aircontrols (USA), Inc.

# GKX24-MFT - Damper Actuator

Modulating, Electronic Fail-Safe, 24 V, Multi-Function Technology®

Accessories	
AH-GMA	GKB(X), GMB(X) crankarm.
AV8-25	9.8" shaft extension for 5/16" to 1" diameter shafts.
KG10A	Ball joint for 3/8" diameter rod, zinc plated.
K-GM20	Standard GK/GM clamp (1/2" to 1.05").
KH10	Univ. crankarm, slot 21/64" w, for 9/16" to 1" dia. shafts.
SH10	Push rod for KG10A ball joint (36" L, 3/8" diameter).
TOOL-07	13 mm wrench.
ZG-100	Univ. right angle bracket (17" H x 11-1/8" W x 6" base).
ZG-101	Univ. right angle bracket (13" H x 11" W x 7-7/16" base).
ZG-102	Dual actuator mounting bracket.
ZG-103	Univ. right angle bracket (7-1/2" H x 11" W x 2-3/4" base).
ZG-104	Univ. right angle bracket (13-5/8" H x 7-1/2" W x 4" base).
ZG-109	Right angle bracket for ZS-260.
ZG-110	Stand-off bracket for ZS-260.
ZG-DC1	Damper clip for damper blade, 3.5" width.
ZG-DC2	Damper clip for damper blade, 6" width.
ZG-GMA	GKB(X), GMB(X) crankarm adaptor kit.
ZG-JSA-1	1" diameter jackshaft adaptor (11" L).
ZG-JSA-2	1-5/16" diameter jackshaft adaptor (12" L).
ZG-JSA-3	1.05" diameter jackshaft adaptor (12" L).
Z-GMA	Classic GM to GMB(X) retrofit bracket.
ZS-100	Weather shield - galvaneal (13" L x 8" W x 6" D).
ZS-101	Base plate for ZS-100.
ZS-150	Weather shield - PC w/ foam seal (16" L x 8-3/8" W x 4" D).
ZS-260	Explosion proof housing.
ZS-300	NEMA 4X, 304 stainless steel enclosure.
ZS-300-5	NEMA 4X, 316L stainless steel enclosure.
ZS-300-C1	1/2" shaft adaptor, standard with ZS-300(-5).
ZS-300-C2	3/4" shaft adaptor for ZS-300(-5).
ZS-300-C3	1" shaft adaptor for ZS-300(-5).
EF-P	Anti-rotation bracket EFB(X)/GKB(X)/GMB(X).
ZG-120	Jackshaft mounting bracket.
ADS-100	Analog to digital switch for modulating actuators.
IRM-100	Input rescaling module for modulating actuators.
MFT-P	Belimo MFT configuration software (hardware not included).
P10000A GR	Feedback potentiometer 10000Ω.
P1000A GR	Feedback potentiometer 1000Ω.
P140A GR	Feedback potentiometer 140Ω.
P2800A GR	Feedback potentiometer 2800Ω.
P5000A GR	Feedback potentiometer 5000Ω.
P500A GR	Feedback potentiometer 500Ω.
PS-100	Actuator power supply and control simulator.
PTA-250	Pulse width modulation interface for modulating actuators.
S1A	Auxiliary switch, 1x SPDT, 3A (0.5A inductive) @250 VAC max.
S2A	Auxiliary switch, 2x SPDT, 3A (0.5A inductive) @250 VAC max.
SGA24	Positioner control for modulating actuators (surface mount).
SGF24	Positioner control for modulating actuators (flush mount).
TF-CC US	Cable conduit connector, 1/2".
UK24BAC	BACnet gateway module for up to 8 MFT actuators.
UK24LON	LON gateway module for up to 8 MFT actuators.
UK24MOD	MODbus gateway module for up to 8 MFT actuators.
ZG-R01	4 to 20 mA adaptor, 500Ω, 1/4 W resistor w 6" pigtail wires.
ZG-R02	50% voltage divider kit (resistors with wires).
ZG-SGF	Mounting plate for SGF.
ZG-X40	120 to 24 VAC, 40 VA transformer.
ZK1-GEN	Cable for ZTH US to diagnostic/programming socket.
ZK2-GEN	Cable for ZTH US to actuators w/o diagnostics socket.
ZK4-GEN	Cable for ZTH US to connect to UK24... gateways and VRP-M.
ZTH US	Handheld programming tool w/ ZK1-GEN, ZK2-GEN, ZK6-GEN.

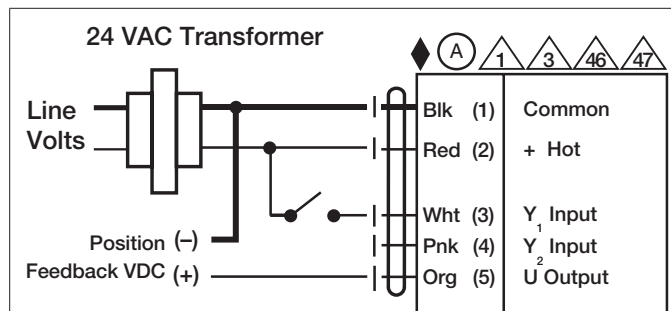

### On/Off

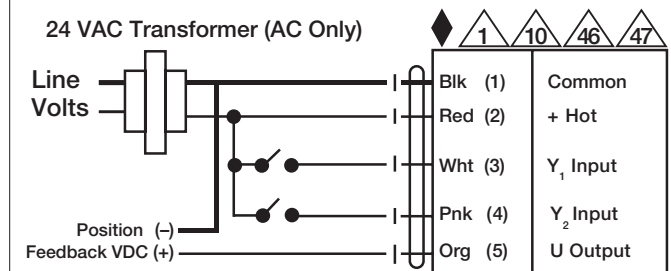

### Floating Point

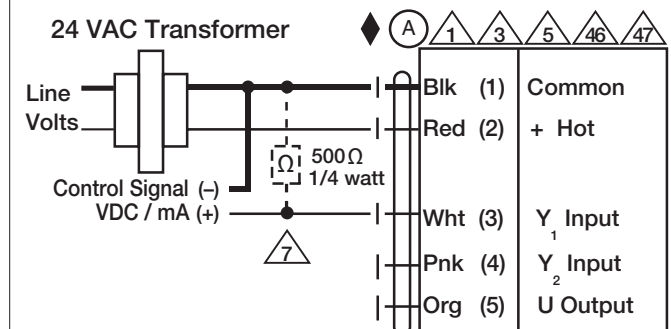

### VDC/mA Control

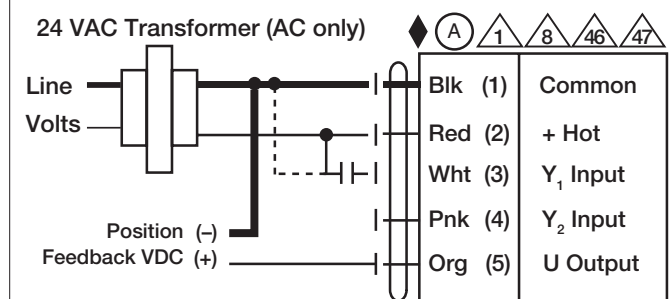

### PWM Control

### Typical Specification

Modulating control, electronic fail-safe damper actuators shall be electronic direct-coupled type, which require no crank arm and linkage and be capable of direct mounting to shaft up to 1.05" diameter. Actuators must provide modulating damper control response to a 2 to 10 VDC or, with the addition of a 500Ω resistor, a 4 to 20 mA control input from an electronic controller or positioner. Actuators shall have brushless DC motor technology and be protected from overload at all angles of rotation. Actuators shall have reversing switch and manual override on the cover. Run time shall be constant and independent of torque. A 2 to 10 VDC feedback signal shall be provided for position feedback or master slave applications. Actuators shall be cULus listed, have a 5-year warranty, and be manufactured under ISO 9001 International Quality Control Standards. Actuators shall be as manufactured by Belimo.

### Wiring Diagrams

**! WARNING! LIVE ELECTRICAL COMPONENTS!**  
 During installation, testing, servicing and troubleshooting of this product, it may be necessary to work with live electrical components. Have a qualified licensed electrician or other individual who has been properly trained in handling live electrical components perform these tasks. Failure to follow all electrical safety precautions when exposed to live electrical components could result in death or serious injury.

- ◆ Meets cULus requirements without the need of an electrical ground connection.
- 1 Provide overload protection and disconnect as required.
- 3 Actuators may also be powered by 24 VDC.
- 5 Only connect common to negative (-) leg of control circuits.
- 7 A 500 Ω resistor (ZG-R01) converts the 4 to 20 mA control signal to 2 to 10 VDC.
- 8 Control signal may be pulsed from either the Hot (Source) or Common (Sink) 24 VAC line.
- 10 For triac sink the Common connection from the actuator must be connected to the Hot connection of the controller. Position feedback cannot be used with a triac sink controller; the actuator internal common reference is not compatible.
- 12 IN4004 or IN4007 diode. (IN4007 supplied, Belimo part number 40155).
- 46 Actuators may be controlled in parallel. Current draw and input impedance must be observed.
- 47 Master-Slave wiring required for piggy-back applications. Feedback from Master to control input(s) of Slave(s).

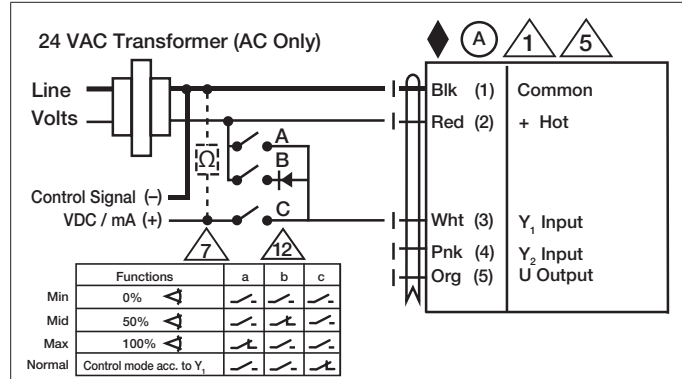

### Override Control

