

LF24-MFT-20 US - Damper Actuator

Modulating, Spring Return, 24 V, for 6 to 9 VDC control and 20 VDC Output Power for Controllers



Technical Data

Power Supply	24 VAC ± 20%, 50/60 Hz, 24 VDC ± 10%
Power Consumption Running	3 W
Power Consumption Holding	1.5 W
Transformer Sizing	6 VA (class 2 power source)
Shaft Diameter	3/8" to 1/2" round, centers on 1/2"
Electrical Connection	3 ft [1 m], 18 GA appliance cable with 1/2" conduit connector
Overload Protection	electronic throughout 0° to 95° rotation
Electrical Protection	actuators are double insulated
Operating Range Y	6 to 9 VDC (Default), P-10005 (A05)
Input Impedance	100 k Ω
Feedback Output U	2 to 10 VDC, 0.5 mA max, VDC variable
Angle of Rotation	max. 95°, adjustable with mechanical stop
Torque	35 in-lbs [4 Nm] minimum
Direction of Rotation (Motor)	reversible with built-in switch
Direction of Rotation (Fail-Safe)	reversible with CW/CCW mounting
Position Indication	visual indicator, 0° to 95° (0° is full spring return position)
Running Time (Motor)	150 sec (default), variable (75 to 300 sec)
Running Time (Fail-Safe)	<25 sec @ -4°F to 122°F [-20°C to 50°C], < 60 sec @ -22°F [-30°C]
Angle of Rotation Adaptation	Off (default)
Override Control	min. position = 0% , mid. Position = 50% , max. position = 100% (Default)
Humidity	max. 95% RH non-condensing
Ambient Temperature Range	-22°F to +122°F [-30°C to +50°C]
Storage Temperature Range	-40°F to +176°F [-40°C to +80°C]
Housing	NEMA 2, IP54
Housing Material	zinc coated steel
Agency Listings†	cULus acc. To UL 873 and CAN/CSA C22.2 No. 24-93
Noise Level (Motor)	<30 dB (A)
Noise Level (Fail-Safe)	<62 dB (A)
Servicing	maintenance free
Quality Standard	ISO 9001
Weight	3.5 lb [1.6 kg]

*Variable when configured with MFT options.

†Rated Impulse Voltage 800V, Type of action 1.AA, Control Pollution Degree 3

Torque min. 35 in-lb, Control 6 to 9 VDC (DEFAULT), Feedback 2 to 10 VDC (DEFAULT)

Application

For fail-safe, modulating control of dampers in HVAC systems. Actuator sizing should be done in accordance with the damper manufacturer's specifications. A feedback signal is provided for position indication.

Default/Configuration

Default parameters for 6 to 9 VDC applications of the LF24-MFT-20 US actuator are assigned during manufacturing. The parameters are variable and can be changed by two means: Set by the customer using PC-Tool software or the handheld ZTH US.

Operation

The LF24-MFT-20 US actuator provides 95° of rotation and is provided with a graduated position indicator showing 0° to 95°. The actuator will synchronize the 0° mechanical stop or the damper or valves mechanical stop and use this point for its zero position during normal control operations. The actuator uses a brushless DC motor which is controlled by an Application Specific Integrated Circuit (ASIC) and a microprocessor. The microprocessor provides the intelligence to the ASIC to provide a constant rotation rate and to know the actuator's exact position. The ASIC monitors and controls the brushless DC motor's rotation and provides a Digital Rotation Sensing (DRS) function to prevent damage to the actuator in a stall condition. The position feedback signal is generated without the need for mechanical feedback potentiometers using DRS. The actuator may be stalled anywhere in its normal rotation without the need of mechanical end switches. The LF24-MFT-20 US is mounted directly to control shafts up to 3/4" diameter (K6-1 clamp) and anti-rotation bracket. A crank arm and several mounting brackets are available for damper applications where the actuator cannot be direct coupled to the damper shaft. The spring return system provides minimum specified torque to the application during a power interruption. The LF24-MFT-20 US actuator is shipped in the zero position, compression against seats or gaskets for tight shut-off is accomplished manually.

Dimensions (Inches[mm])

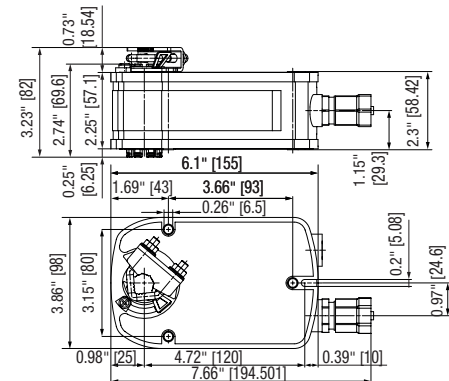

Date created, 09/02/2016 - Subject to change. © Belimo Aircontrols (USA), Inc.

Accessories	
AV6-20	6.7" shaft extension for 1/4" to 3/4" diameter shafts.
IND-LF	LF position indicator.
K6 US	Standard LF clamp (3/8" to 1/2").
K6-1	LF clamp (1/2" to 3/4").
KG10A	Ball joint for 3/8" diameter rod, zinc plated.
KG6	Ball joint for 5/16" diameter rod, zinc plated.
KG8	Ball joint for 5/16" diameter rod, 90°, galvanized steel.
KH12	Univ. crankarm, slot 21/64" w, for 3/4" to 1" dia. shafts.
KH6	Univ. crankarm, slot 1/4" w, for 3/8" to 11/16" dia. shafts.
KH8	Univ. crankarm, slot 21/64" w, for 3/8" to 11/16" dia. shafts.
KH-LF	LF crankarm (with 1/2" diameter shaft pass through).
KH-LFV	V-bolt Kit for KH-LF.
LF-P	Anti-rotation bracket LF.
SH10	Push rod for KG10A ball joint (36" L, 3/8" diameter).
SH8	Push rod for KG6 & KG8 ball joints (36" L, 5/16" diameter).
TOOL-06	8 mm and 10 mm wrench.
ZDB-LF	Angle of rotation Limiter for LF.
ZF8-LF	8x8 mm form fit adaptor for LF.
ZG-109	Right angle bracket for ZS-260.
ZG-110	Stand-off bracket for ZS-260.
ZG-112	LF right angle bracket (4-1/2" H x 5-1/2" W x 2-1/2" D).
ZG-DC1	Damper clip for damper blade, 3.5" width.
ZG-DC2	Damper clip for damper blade, 6" width.
ZG-LF112	LF crankarm adaptor kit (includes ZG-112).
ZG-LF2	LF crankarm adaptor kit (T bracket included).
ZG-LMSA-1	Shaft extension for 3/8" diameter shafts (4" L).
ZG-LMSA-1/2-5	Shaft extension for 1/2" diameter shafts (5" L).
ZS-100	Weather shield - galvanneal (13" L x 8" W x 6" D).
ZS-101	Base plate for ZS-100.
ZS-150	Weather shield - PC w/ foam seal (16" L x 8-3/8" W x 4" D).
ZS-260	Explosion proof housing.
ZS-300	NEMA 4X, 304 stainless steel enclosure.
ZS-300-5	NEMA 4X, 316L stainless steel enclosure.
ZS-300-C1	1/2" shaft adaptor, standard with ZS-300(-5).
ZS-300-C2	3/4" shaft adaptor for ZS-300(-5).
ZS-300-C3	1" shaft adaptor for ZS-300(-5).
ADS-100	Analog to digital switch for modulating actuators.
IRM-100	Input rescaling module for modulating actuators.
MFT-P	Belimo MFT configuration software (hardware not included).
PS-100	Actuator power supply and control simulator.
PTA-250	Pulse width modulation interface for modulating actuators.
SGA24	Positioner control for modulating actuators (surface mount).
SGF24	Positioner control for modulating actuators (flush mount).
UK24BAC	BACnet gateway module for up to 8 MFT actuators.
UK24LON	LON gateway module for up to 8 MFT actuators.
UK24MOD	MODbus gateway module for up to 8 MFT actuators.
ZG-R01	4 to 20 mA adaptor, 500Ω, 1/4 W resistor w 6" pigtail wires.
ZG-R02	50% voltage divider kit (resistors with wires).
ZG-SGF	Mounting plate for SGF.
ZG-X40	120 to 24 VAC, 40 VA transformer.
ZK2-GEN	Cable for ZTH US to actuators w/o diagnostics socket.
ZTH US	Handheld programming tool w/ ZK1-GEN, ZK2-GEN, ZK6-GEN.

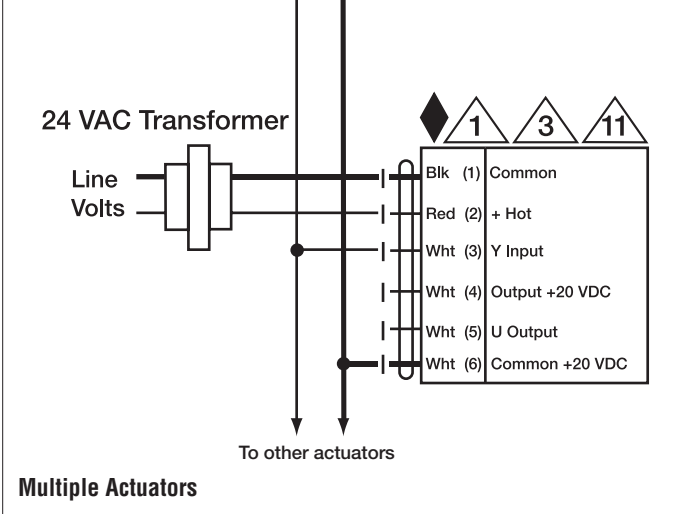
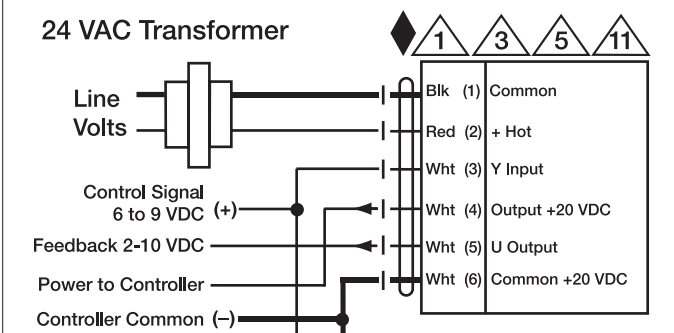
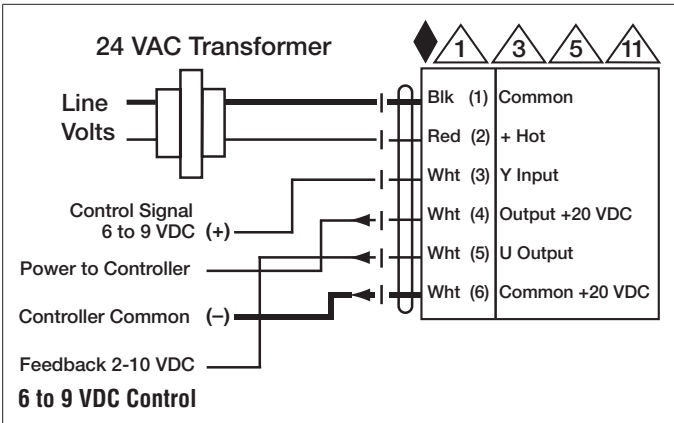

LF24-MFT-20 US - Damper Actuator

Modulating, Spring Return, 24 V, for 6 to 9 VDC control and 20 VDC Output Power for Controllers



Typical Specification

Spring return control damper actuators shall be direct coupled type which require no crank arm and linkage and be capable of direct mounting to a shaft up to a 3/4" diameter and center on a 1/2" shaft (default). Actuator shall deliver a minimum output torque of 35 in-lbs. The actuator must provide modulating damper control in response to a 6 to 9 VDC control input from an electronic controller or positioner. The actuators must be designed so that they may be used for either clockwise or counter clockwise fail-safe operation. Actuators shall use a brushless DC motor controlled by a microprocessor and be protected from overload at all angles of rotation. Run time shall be constant, and independent of torque. A 2 to 10 VDC feedback signal shall be provided for position feedback. Actuators with auxiliary switches must be constructed to meet the requirements for Double Insulation so an electrical ground is not required to meet agency listings. Actuators shall be cULus listed and have a 5 year warranty, and be manufactured under ISO 9001 International Quality Control Standards. Actuators shall be as manufactured by Belimo.

Wiring Diagrams



WARNING! LIVE ELECTRICAL COMPONENTS!

During installation, testing, servicing and troubleshooting of this product, it may be necessary to work with live electrical components. Have a qualified licensed electrician or other individual who has been properly trained in handling live electrical components perform these tasks. Failure to follow all electrical safety precautions when exposed to live electrical components could result in death or serious injury.



Meets cULus requirements without the need of an electrical ground connection.



Provide overload protection and disconnect as required.



Actuators may also be powered by 24 VDC.



Only connect common to negative (-) leg of control circuits.



Actuators may be connected in parallel if not mechanically linked. Power consumption and input impedance must be observed.