

NMX24-SR

Modulating, Non-Spring Return, 24 V, for 2 to 10 VDC or 4 to 20 mA



Technical Data

Power Supply	24 VAC, ±20%, 50/60 Hz, 24 VDC, ±10%
Power Consumption Running	2.5 W
Power Consumption Holding	0.4 W
Transformer Sizing	5 VA (class 2 power source)
Shaft Diameter	1/2" to 1.05" round, centers on 1/2" and 3/4" with insert, 1.05" without insert
Electrical Connection	18 GA plenum rated cable with 1/2" conduit connector protected NEMA 2 (IP54) 3ft [1m] 10ft [3m] and 16ft [5m]
Overload Protection	electronic throughout 0° to 95° rotation
Operating Range Y	2 to 10 VDC, 4 to 20 mA w/ ZG-R01 (500 Ω, 1/4 W resistor)
Input Impedance	100 kΩ (0.1 mA), 500 Ω
Angle of Rotation	Max. 95°, adjustable with mechanical stop
Torque motor	Min. 90 in-lbs [10 Nm]
Direction of Rotation (Motor)	reversible with built-in switch
Position Indication	reflective visual indicator (snap on)
Manual Override	external push button
Running Time (Motor)	95 sec
Ambient Humidity	5 to 95% RH non condensing (EN 60730-1)
Ambient Temperature Range	-22°F to 122°F [-30°C to 50°C]
Storage Temperature Range	-40°F to 176°F [-40°C to 80°C]
Housing	NEMA 2, IP54, UL Enclosure Type 2
Housing Material	UL94-5VA
Agency Listings†	cULus acc. to UL60730-1A/-2-14, CAN/CSA E60730-1:02, CE acc. to 2004/108/EC and 2006/95/EC
Noise Level (Motor)	<45 dB (A)
Servicing	maintenance free
Quality Standard	ISO 9001
Weight	1.8 lb [0.8 kg]

†Rated Impulse Voltage 800V, Type action 1, Control Pollution Degree 3.

Torque min. 90 in-lb, for control of damper surfaces up to 22 sq. ft.

Application

For proportional modulation of dampers in HVAC systems. Actuator sizing should be done in accordance with the damper manufacturer's specifications.

The actuator is mounted directly to a damper shaft up to 1.05" in diameter by means of its universal clamp, 1/2" self centered default. A crank arm and several mounting brackets are available for applications where the actuator cannot be direct coupled to the damper shaft.

The actuator operates in response to a 2 to 10 VDC, or with the addition of a 500 Ω resistor, a 4 to 20 mA control input from an electronic controller or positioner. A 2 to 10 VDC feedback signal is provided for position indication or master-slave applications.

Operation

The actuator is not provided with and does not require any limit switches, but is electronically protected against overload. The anti-rotation strap supplied with the actuator will prevent lateral movement.

The NMB(X) series provides 95° of rotation and a visual indicator indicates position of the actuator. When reaching the damper or actuator end position, the actuator automatically stops. The gears can be manually disengaged with a button on the actuator cover.

The NMB(X)24-SR... actuators use a sensorless brushless DC motor, which is controlled by an Application Specific Integrated Circuit (ASIC). The ASIC monitors and controls the actuator's rotation and provides a digital rotation sensing (DRS) function to prevent damage to the actuator in a stall condition. Power consumption is reduced in holding mode.

Add-on auxiliary switches or feedback potentiometers are easily fastened directly onto the actuator body for signaling and switching functions.

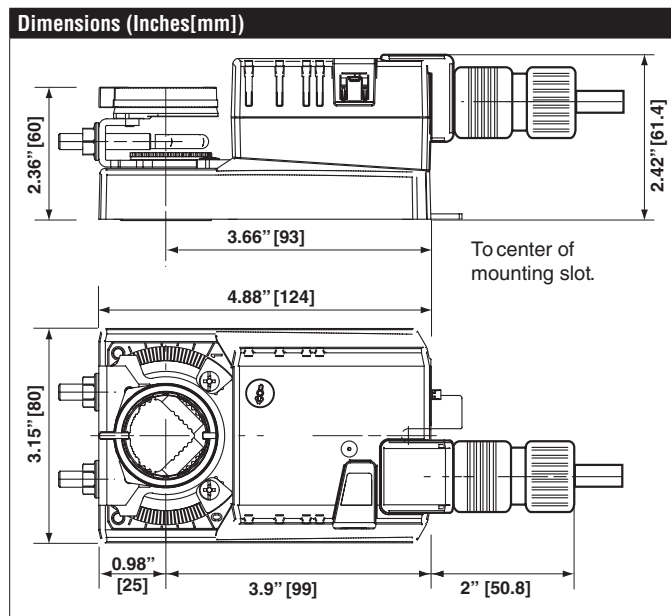

Accessories

K-NA	Reversible NMB(X) Clamp (1/2" to 3/4").
ZG-100	Univ. right angle bracket (17" H x 11-1/8" W x 6" base).
ZG-101	Univ. right angle bracket (13" H x 11" W x 7-7/16" base).
ZG-103	Univ. right angle bracket (7-1/2" H x 11" W x 2-3/4" base).
ZG-104	Univ. right angle bracket (13-5/8" H x 7-1/2" W x 4" base).
ZG-NMA	AMB(X), NMB(X), NKQB(X) crankarm adaptor kit.
AV8-25	9.8" shaft extension for 5/16" to 1" diameter shafts.
ZG-NMSA-1	Shaft extension for 1/2" diameter shafts (3.8" L).
ZS-T	Terminal-strip cover for NEMA 2 rating (-T models).
ZS-100	Weather shield - galvaneal (13" L x 8" W x 6" D).
ZS-150	Weather shield - PC w/ foam seal (16" L x 8-3/8" W x 4" D).
TOOL-06	8 mm and 10 mm wrench.
S1A	Auxiliary switch, 1x SPDT, 3A (0.5A inductive) @250 VAC max.
S2A	Auxiliary switch, 2x SPDT, 3A (0.5A inductive) @250 VAC max.
P370	Shaft mount auxiliary switch, 1/2" shaft.
P10000A GR	Feedback potentiometer 10000Ω.
P1000A GR	Feedback potentiometer 1000Ω.
P140A GR	Feedback potentiometer 140Ω.
P2800A GR	Feedback potentiometer 2800Ω.
P5000A GR	Feedback potentiometer 5000Ω.
P500A GR	Feedback potentiometer 500Ω.
SGA24	Positioner control for modulating actuators (surface mount).
PTA-250	Pulse width modulation interface for modulating actuators.
IRM-100	Input rescaling module for modulating actuators.
ADS-100	Analog to digital switch for modulating actuators.
ZG-R01	4 to 20 mA adaptor, 500Ω, 1/4 W resistor w 6" pigtail wires.
NSV24 US	Battery back-up module for non-spring return actuators.
ZG-X40	120 to 24 VAC, 40 VA transformer.

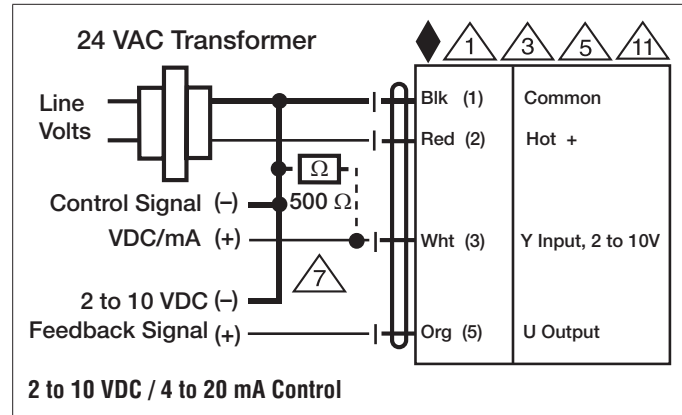
Typical Specification

Proportional control damper actuators shall be electronic direct-coupled type, which require no crank arm and linkage and be capable of direct mounting to a shaft from 1/4" to 1/2" diameter. Actuators must provide proportional damper control response to a 2 to 10 VDC or, with the addition of a 500Ω resistor, a 4 to 20 mA control input from an electronic controller or positioner. Actuators shall have brushless DC motor technology and be protected from overload at all angles of rotation. Actuators shall have manual override on the cover. Run time shall be constant and independent of torque. Actuators shall be cULus listed, have a 5-year warranty, and be manufactured under ISO 9001 International Quality Control Standards. Actuators shall be as manufactured by Belimo.

Wiring Diagrams

- Provide overload protection and disconnect as required.
- Actuators may also be powered by 24 VDC.
- Only connect common to negative (-) leg of control circuits.
- A 500 Ω resistor (ZG-R01) converts the 4 to 20 mA control signal to 2 to 10 VDC.
- Actuators may be connected in parallel if not mechanically linked. Power consumption and input impedance must be observed.