

TFB24-3-S - Damper Actuator

On/Off, Floating Point, Spring Return, 24 V



Technical Data	
Power Supply	24 VAC, ±20%, 50/60 Hz, 24 VDC, ±10%
Power Consumption Running	2.5 W
Power Consumption Holding	1 W
Transformer Sizing	4 VA (class 2 power source)
Shaft Diameter	1/4" to 1/2" round, centers on 1/2"
Electrical Connection	(2) 3ft [1m], 18 GA appliance cables with 1/2" conduit connectors
Overload Protection	electronic throughout 0° to 95° rotation
Electrical Protection	actuators are double insulated
Operating Range Y	on/off, floating point
Input Impedance	1000 Ω (0.6 W)
Angle of Rotation	Max. 95°, adjustable with mechanical stop
Torque motor	Min. 22 in-lbs [2.5 Nm]
Direction of Rotation (Motor)	reversible with built-in switch
Direction of Rotation (Fail-Safe)	reversible with CW/CCW mounting
Position Indication	visual indicator, 0° to 95° (0° is full spring return position)
Running Time (Motor)	95 sec
Running Time (Fail-Safe)	<25 sec @ -4°F to 122°F [-20°C to 50°C], <60 sec @ -22°F [-30°C]
Ambient Humidity	max. 95% RH non-condensing
Ambient Temperature Range	-22°F to 122°F [-30°C to 50°C]
Storage Temperature Range	-40°F to 176°F [-40°C to 80°C]
Housing	NEMA 2, IP42, UL Enclosure Type 2
Housing Material	UL94-5VA
Agency Listings†	cULus acc. to UL60730-1A/-2-14, CAN/CSA E60730-1:02, CE acc. to 2004/108/EC and 2006/95/EC
Noise Level (Motor)	<35 dB (A)
Noise Level (Fail-Safe)	<62 dB (A)
Servicing	maintenance free
Quality Standard	ISO 9001
Weight	1.5 lb [0.7 kg]
Auxiliary switch	1 x SPDT, 3A resistive (0.5A inductive) @ 250 VAC, adjustable 0° to 95°

†Rated Impulse Voltage 800V, Type of Action 1.AA.B, Control Pollution Degree 3.

Torque min. 22 in-lb, for control of air dampers.

Application

For modulation or On/Off, fail-safe control of dampers in HVAC systems. Actuator sizing should be done in accordance with the damper manufacturer's specifications. The actuator is mounted directly to a damper shaft from 1/4" up to 1/2" in diameter by means of its universal clamp, 1/2" shaft centered at delivery. A crank arm and several mounting brackets are available for applications where the actuator cannot be direct coupled to the damper shaft. Control is floating point from a triac or relay, or On/Off from an auxiliary contact on a fan motor contactor, controller or manual switch.

Operation

The TF series actuators provide true spring return operation for reliable fail-safe application and positive close-off on air tight dampers. The spring return system provides consistent torque to the damper with, and without, power applied to the actuator. The TF series provides 95° of rotation and is provided with a graduated position indicator showing 0 to 95°. The TF uses a brushless DC motor which is controlled by an Application Specific Integrated Circuit (ASIC) and a microprocessor. The microprocessor provides the intelligence to the ASIC to provide a constant rotation rate and to know the actuator's exact fail-safe position. The ASIC monitors and controls the brushless DC motor's rotation and provides a digital rotation sensing function to prevent damage to the actuator in a stall condition. The actuator may be stalled anywhere in its normal rotation without the need of mechanical end switches. Power consumption is reduced in holding mode. The TF -S versions are provided with one built-in auxiliary switch. This SPDT switch is provided for safety interfacing or signaling, for example, for fan start-up. The switching function is adjustable between 0° and 95°.

Safety Note: Screw a conduit fitting into the actuator's bushing. Jacket the actuator's input and output wiring with suitable flexible conduit. Properly terminate the conduit in a suitable junction box.

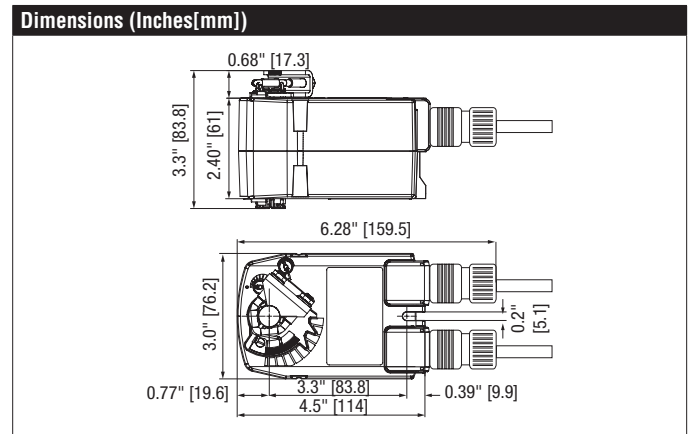

Date created, 11/29/2017 - Subject to change. © Belimo Aircontrols (USA), Inc.

Accessories	
AV6-20	6.7" shaft extension for 1/4" to 3/4" diameter shafts.
IND-TF	TF position indicator.
K8 US	Standard TFB(X) clamp (1/4" to 1/2").
KG10A	Ball joint for 3/8" diameter rod, zinc plated.
KG6	Ball joint for 5/16" diameter rod, zinc plated.
KG8	Ball joint for 5/16" diameter rod, 90°, galvanized steel.
KH12	Univ. crankarm, slot 21/64" w, for 3/4" to 1" dia. shafts.
KH6	Univ. crankarm, slot 1/4" w, for 3/8" to 11/16" dia. shafts.
KH8	Univ. crankarm, slot 21/64" w, for 3/8" to 11/16" dia. shafts.
KH-TF US	TFB(X) crankarm with 5/16" slot.
KH-TF-1 US	TFB(X) crankarm with 1/4" slot.
KH-TF-1.1 US	TFB(X) crankarm for Shafts with 1/4" slot.
SB-TF	TFB(X) mounting kit (T-bracket, bolts).
SH10	Push rod for KG10A ball joint (36" L, 3/8" diameter).
SH8	Push rod for KG6 & KG8 ball joints (36" L, 5/16" diameter).
TF-P	Anti-rotation bracket TF/NKQ/AM/NM/LM.
TOOL-06	8 mm and 10 mm wrench.
ZDB-TF	Angle of rotation limiter for TFB(X).
ZG-113	TFB(X) right angle bracket (4-1/2" H x 5-1/2" W x 2-1/2" D).
ZG-DC1	Damper clip for damper blade, 3.5" width.
ZG-DC2	Damper clip for damper blade, 6" width.
ZG-LMSA-1	Shaft extension for 3/8" diameter shafts (4" L).
ZG-LMSA-1/2-5	Shaft extension for 1/2" diameter shafts (5" L).
ZG-TF112	TFB(X) crankarm adaptor kit (includes ZG-113).
ZG-TF2	TFB(X) crankarm adaptor kit (T bracket included).
ZG-TF3	TFB(X) Mounting Hardware without bracket.
ZS-100	Weather shield - galvanneal (13" L x 8" W x 6" D).
ZS-101	Base plate for ZS-100.
ZS-150	Weather shield - PC w/ foam seal (16" L x 8-3/8" W x 4" D).
PS-100	Actuator power supply and control simulator.
TF-CC US	Cable conduit connector, 1/2".
ZG-X40	120 to 24 VAC, 40 VA transformer.

Typical Specification

Floating point, On/Off spring return damper actuators shall be direct coupled type which require no crank arm and linkage and be capable of direct mounting to a shaft up to a 1/2" diameter and center a 1/2" shaft. The actuators must be designed so that they may be used for either clockwise or counter clockwise fail-safe operation. Actuators shall have an external direction of rotation switch to reverse control logic. Actuators shall use a brushless DC motor and be protected from overload at all angles of rotation. If required, one SPDT auxiliary switch shall be provided having the capability of being adjustable. Actuators with auxiliary switch must be constructed to meet the requirements for Double Insulation so an electrical ground is not required to meet agency listings. Run time shall be constant and independent of torque. Actuators shall be cULus listed, have a 5 year warranty, and be manufactured under ISO 9001 International Quality Control Standards. Actuators shall be as manufactured by Belimo.

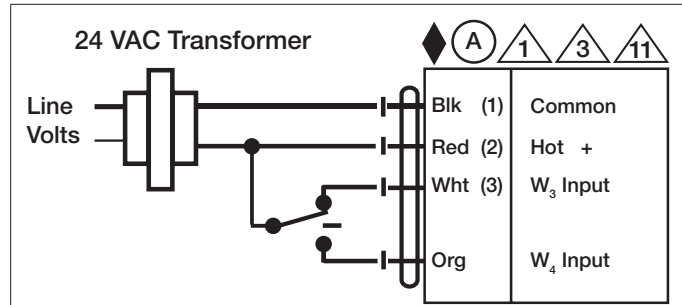

Floating Point

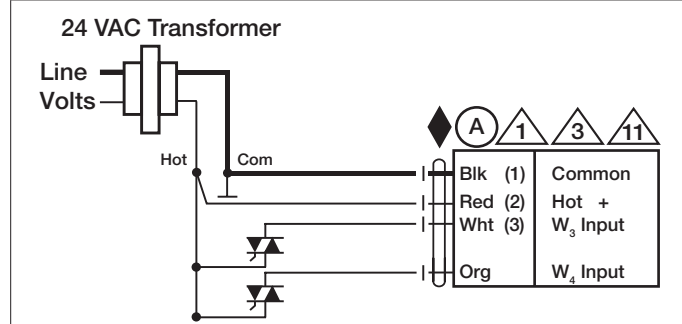

Floating Point - Triac Source

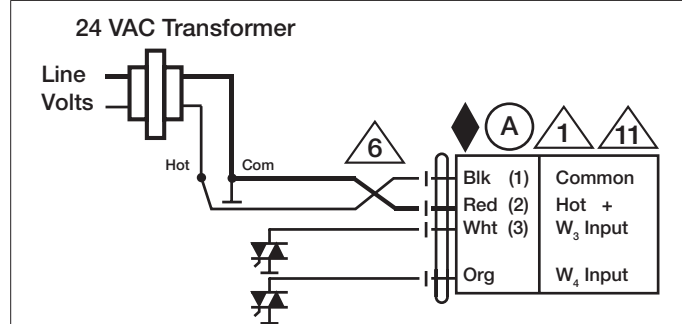

Floating Point - Triac Sink

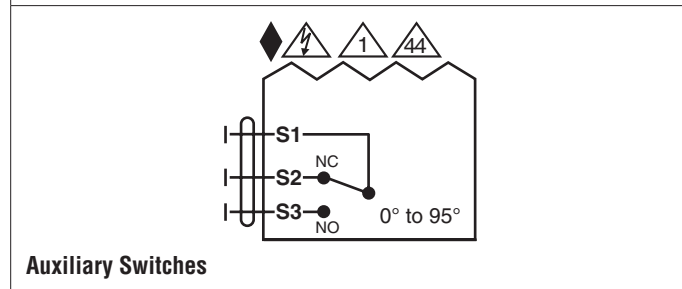

Auxiliary Switches

TFB24-3-S - Damper Actuator

On/Off, Floating Point, Spring Return, 24 V

Wiring Diagrams



WARNING! LIVE ELECTRICAL COMPONENTS!

During installation, testing, servicing and troubleshooting of this product, it may be necessary to work with live electrical components. Have a qualified licensed electrician or other individual who has been properly trained in handling live electrical components perform these tasks. Failure to follow all electrical safety precautions when exposed to live electrical components could result in death or serious injury.



Meets cULus requirements without the need of an electrical ground connection.



Apply only AC line voltage or only UL-Class 2 voltage to the terminals of auxiliary switches. Mixed or combined operation of line voltage/safety extra low voltage is not allowed.



Actuators with appliance cables are numbered.



Provide overload protection and disconnect as required.



Actuators may also be powered by 24 VDC.



Actuators Hot wire must be connected to the control board common. Only connect common to neg. (-) leg of control circuits. Terminal models (-T) have no-feedback.



Actuators may be connected in parallel if not mechanically linked. Power consumption and input impedance must be observed.



One built-in auxiliary switch (1x SPDT), for end position indication, interlock control, fan startup, etc.