

# Z2050Q-F, 1/2", ZoneTight Valve



Technical Data	
Service	chilled, hot water, up to 60% glycol
Flow Characteristic	equal percentage
Controllable Flow Range	75°
Size [mm]	0.5" [15]
End Fitting	NPT female ends
Body	forged brass
Ball	chrome plated brass
Stem	brass
Seat	Teflon® PTFE
Seat O-ring	EPDM (lubricated)
Diaphragm	EPDM
Body Pressure Rating [psi]	360
Media Temperature Range (Water)	36°F to 212°F [2°C to 100°C]
Maximum Allowable Operating Temperature	212°F [100°C] *
Media Temperature Limit	250°F [121°C] *
Max Differential Pressure (Water)	40 psi
Close-Off Pressure	75 psi
Cv	1.4
Weight	0.2 lb [0.1 kg]
Leakage	0%
Servicing	maintenance free

\* If temperature exceeds 212°F operating range due to a boiler control failure the valve will safely contain the hot water but manufacturers product warranty becomes invalid. Valve and actuator replacement is at the expense of others.

## Application

The QCV zone valves are suited for large commercial buildings where higher close-off and the ability to change flow is desired. Common applications include unit ventilators, fan coil units, VAV reheat coils, fin tube casing, radiant panels and duct coils. The valve fits in space restricted areas and can be assembled without the use of tools.

## Suitable Actuators

	Non-Spring	Electronic Fail-Safe
Z2050Q-F	CQ	CQK

## Dimensions (Inches [mm])

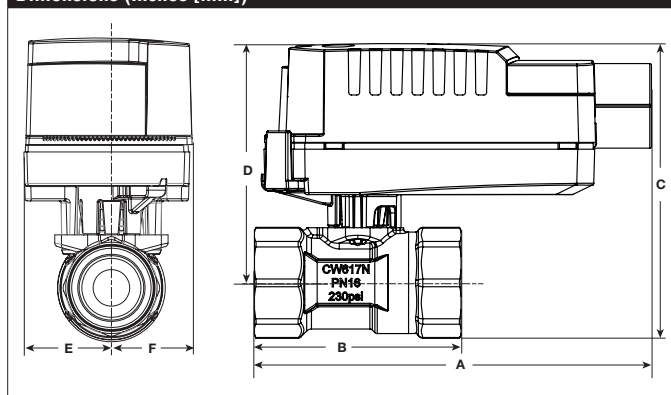

A	B	C	D	E	F
4.5" [114]	2.05" [52]	3.27" [83]	2.71" [69]	0.94" [23.88]	0.94" [24]

**Dimensions (Inches [mm])**

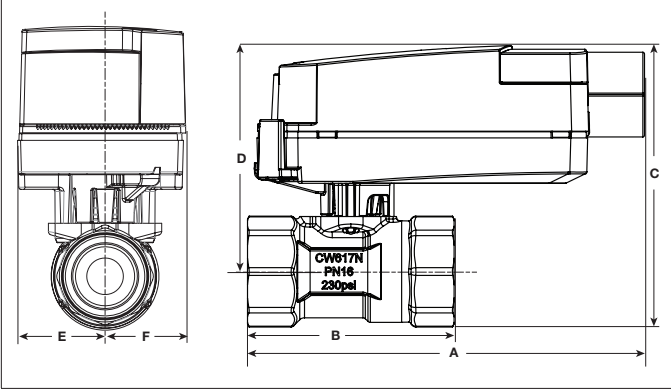

A	B	C	D	E	F
4.5" [114]	2.05" [52]	3.14" [80]	2.56" [65]	1.02" [26]	

# CQKB24-LL

On/Off, Electronic-Fail-safe, 24V



### Technical Data

Power Supply	24 VAC, $\pm 20\%$ , 50/60 Hz, 24 VDC, $\pm 10\%$
Power Consumption Running	2.5 W
Power Consumption Holding	0.5 W
Transformer Sizing	5 VA (class 2 power source)
Electrical Connection	3ft [1m], 18 GA plenum cable with 1/2" conduit connector
Overload Protection	electronic throughout 0° to 90° rotation
Operating Range Y	on/off
Angle of Rotation	90°, adjustable with mechanical stop
Position Indication	pointer
Running Time (Motor)	75 sec
Running Time (Fail-Safe)	<60 sec
Bridge Time	2 sec delay before fail-safe activates
Pre-charging Time	5 to 20 seconds
Ambient Humidity	5 to 95% RH non-condensing
Ambient Temperature Range	35°F to 104°F [1.7°C to 40°C]
Storage Temperature Range	-40°F to 176°F [-40°C to 80°C]
Housing	IP40, NEMA 2
Housing Material	UL94-5VA
Agency Listings†	cULus acc. to UL60730-1A/-2-14, CAN/CSA E60730-1:02, CE acc. to 2004/108/EC and 2006/95/EC
Noise Level (Motor)	max. 35 dB (A)
Servicing	maintenance free
Quality Standard	ISO 9001
Weight	0.4 lb [0.2 kg]
Degree of Protection IEC/EN	IP40

† Use flexible metal conduit. Push the listed conduit fitting device over the actuator's cable to butt against the enclosure. Screw in conduit connector. Jacket the actuators input wiring with listed flexible conduit. Properly terminate the conduit in a suitable junction box. Rated impulse Voltage 800V. Type of action 1. Control pollution degree 3.

**Wiring Diagrams**

**✂ INSTALLATION NOTES**

- Actuators with appliance cables are numbered.
- Actuators may be connected in parallel. Power consumption and input impedance must be observed.
- Actuators may also be powered by 24 VDC.
- Actuators with plenum cable do not have numbers; use color codes instead.
- Meets cULus requirements without the need of an electrical ground connection.

**WARNING! LIVE ELECTRICAL COMPONENTS!**  
During installation, testing, servicing and troubleshooting of this product, it may be necessary to work with live electrical components. Have a qualified licensed electrician or other individual who has been properly trained in handling live electrical components perform these tasks. Failure to follow all electrical safety precautions when exposed to live electrical components could result in death or serious injury.

