

Z2075Q-K, 3/4", ZoneTight Valve



Technical Data	
Service	chilled, hot water, up to 60% glycol
Flow Characteristic	equal percentage
Controllable Flow Range	75°
Size [mm]	0.75" [20]
End Fitting	NPT female ends
Body	forged brass
Ball	chrome plated brass
Stem	brass
Seat	Teflon® PTFE
Seat O-ring	EPDM (lubricated)
Body Pressure Rating [psi]	360
Media Temperature Range (Water)	36°F to 212°F [2°C to 100°C]
Maximum Allowable Operating Temperature	212°F [100°C] *
Media Temperature Limit	250°F [121°C] *
Max Differential Pressure (Water)	40 psi
Close-Off Pressure	75 psi
Cv	9.8
Weight	0.4 lb [0.2 kg]
Leakage	0%
Servicing	maintenance free

* If temperature exceeds 212°F operating range due to a boiler control failure the valve will safely contain the hot water but manufacturers product warranty becomes invalid. Valve and actuator replacement is at the expense of others.

Application

The QCV zone valves are suited for large commercial buildings where higher close-off and the ability to change flow is desired. Common applications include unit ventilators, fan coil units, VAV reheat coils, fin tube casing, radiant panels and duct coils. The valve fits in space restricted areas and can be assembled without the use of tools.

Suitable Actuators

	Non-Spring	Electronic Fail-Safe
Z2075Q-K	CQ	CQK

Dimensions (Inches [mm])

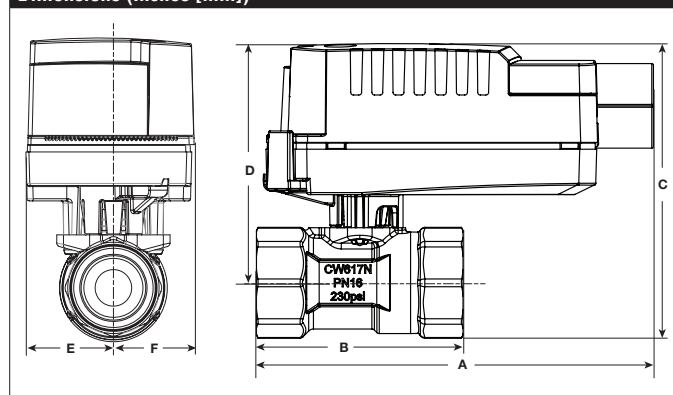

A	B	C	D	E	F
4.5" [114]	2.4" [61]	3.42" [86.9]	2.77" [70]	0.94" [23.88]	0.94" [24]

Dimensions (Inches [mm])



A	B	C	D	E	F
4.5" [114]	2.4" [61]	3.27" [83]	2.63" [67]		1.2" [31]

CQBUP-3

On/Off, Floating Point, Non-Spring Return, 100 to 240 VAC



Technical Data	
Power Supply	100...240 VAC, -15% / +10%, 50/60 Hz
Power Consumption Running	1 W
Power Consumption Holding	0.7 W
Transformer Sizing	2 VA (class 2 power source)
Electrical Connection	3ft [1m], 18 GA plenum cable with 1/2" conduit connector
Overload Protection	electronic throughout 0° to 90° rotation
Angle of Rotation	90°, adjustable with mechanical stop
Position Indication	pointer
Running Time (Motor)	75 sec
Ambient Humidity	5 to 95% RH non condensing (EN 60730-1)
Ambient Temperature Range	35°F to 104°F [1.7°C to 40°C]
Storage Temperature Range	-40°F to 176°F [-40°C to 80°C]
Housing	IP40, NEMA 2
Housing Material	UL94-5VA
Agency Listings†	cULus acc. to UL60730-1A/-2-14, CAN/CSA E60730-1-02, CE acc. to 2004/108/EC and 2006/95/EC
Noise Level (Motor)	max. 35 dB (A)
Servicing	maintenance free
Quality Standard	ISO 9001
Weight	0.4 lb [0.2 kg]
Degree of Protection IEC/EN	IP40

† Use flexible metal conduit. Push the listed conduit fitting device over the actuator's cable to butt against the enclosure. Screw in conduit connector. Jacket the actuators input wiring with listed flexible conduit. Properly terminate the conduit in a suitable junction box. Rated impulse Voltage 800V. Type of action 1. Control pollution degree 3.

Application

Non-Spring Return On/Off/Floating Point ZoneTight actuator.

Valve selection should be done in accordance with the flow parameters and system specifications. The actuator is mounted directly to the valve without the need for tools or additional linkage.

Angle of rotation is adjustable with the integrated mechanical stop.

Wiring Diagrams
INSTALLATION NOTES

- Actuators with appliance cables are numbered.
- Actuators may be connected in parallel. Power consumption and input impedance must be observed.
- Actuators with plenum cable do not have numbers; use color codes instead.
- Meets cULus requirements without the need of an electrical ground connection.
- Apply only AC line voltage or only UL-Class 2 voltage to the terminals of auxiliary switches. Mixed or combined operation of line voltage/safety extra low voltage is not allowed.

WARNING! LIVE ELECTRICAL COMPONENTS!
 During installation, testing, servicing and troubleshooting of this product, it may be necessary to work with live electrical components. Have a qualified licensed electrician or other individual who has been properly trained in handling live electrical components perform these tasks. Failure to follow all electrical safety precautions when exposed to live electrical components could result in death or serious injury.

