

CLEVELAND CONTROLS

Model AFS-460-137

Manual Reset DPDT Air Pressure Sensing Switch for 24 VAC Applications

Application

The Model AFS-460-137 is a general purpose airflow proving switch designed for 24 VAC HVAC and Energy Management applications where a manual reset switch with DPDT contacts is desirable. It may be used to sense positive, negative, or differential air pressure.

General Description & Operation

The plated housing contains a diaphragm, a calibration spring, a snap-acting switch with manual reset button, and a dpdt relay.

The sample connections located on each side of the diaphragm accept .25" OD tubing via the integral compression ferrule and nut.

An enclosure cover guards against accidental contact with the live switch terminal screws and the set point adjusting screw. The enclosure cover will accept a 0.5" conduit connection. The manual reset button is located on the top surface of the enclosure cover.

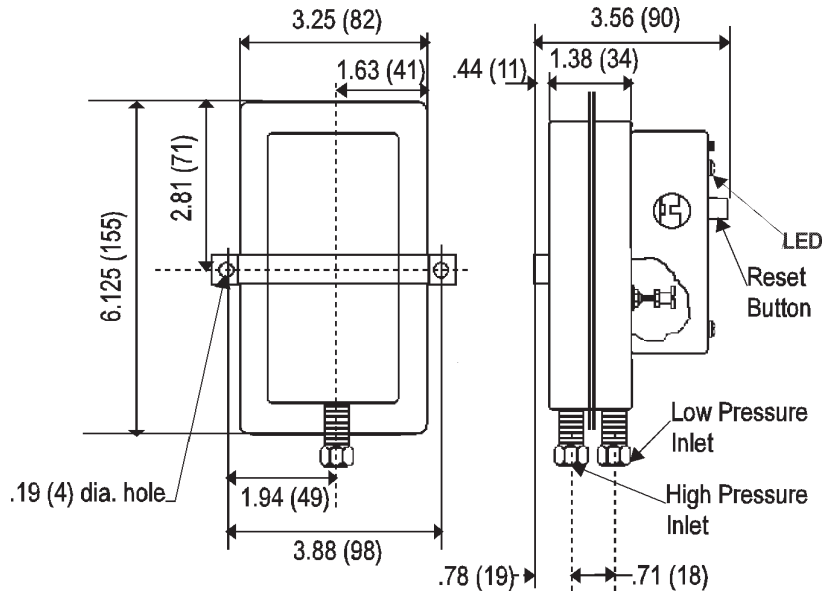
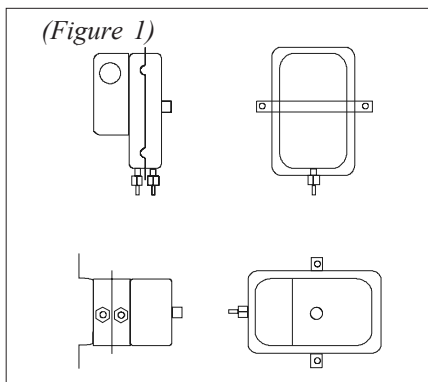

Mounting (see Figure 1)

Select a mounting location which is free from vibration. The AFS-460-137 must be mounted with the diaphragm in any vertical plane in order to obtain the lowest specified operating set point. Avoid mounting with the sample line connections in the "up" position. Surface mount via the two $\frac{3}{16}$ " diameter holes in the integral mounting bracket. The mounting holes are $3\text{-}\frac{7}{8}$ " apart.

Air Sampling Connection (see Figure 2)

The AFS-460-137 is designed to accept firm-wall sample lines of $\frac{1}{4}$ " OD tubing by means of ferrule and nut compression connections. An optional $\frac{1}{4}$ " adapter, suitable for slip-on flexible tubing is available. For sample lines of up

to 10 feet, $\frac{1}{4}$ " OD tubing is acceptable. For lines up to 20 feet, use $\frac{1}{4}$ " ID tubing. For lines up to 60 feet, use $\frac{1}{2}$ " ID tubing. Locate the sampling probe a minimum of 1.5 duct diameters downstream from the air source. Install the sampling probe as close to the center of the airstream as possible. Refer to Figure 2 to identify the high pressure inlet (H), and the low pressure inlet (L). Select one of the five application options listed below, and connect the sample lines as recommended.

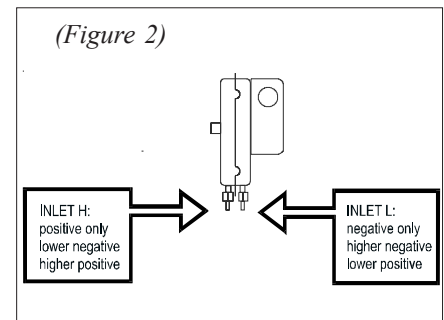

Distributed by:

Cleveland Controls
Division of UniControl Inc.
111 Brookpark Road • Cleveland OH 44109
TEL: (216) 398-0330 • FAX: (216) 398-8558

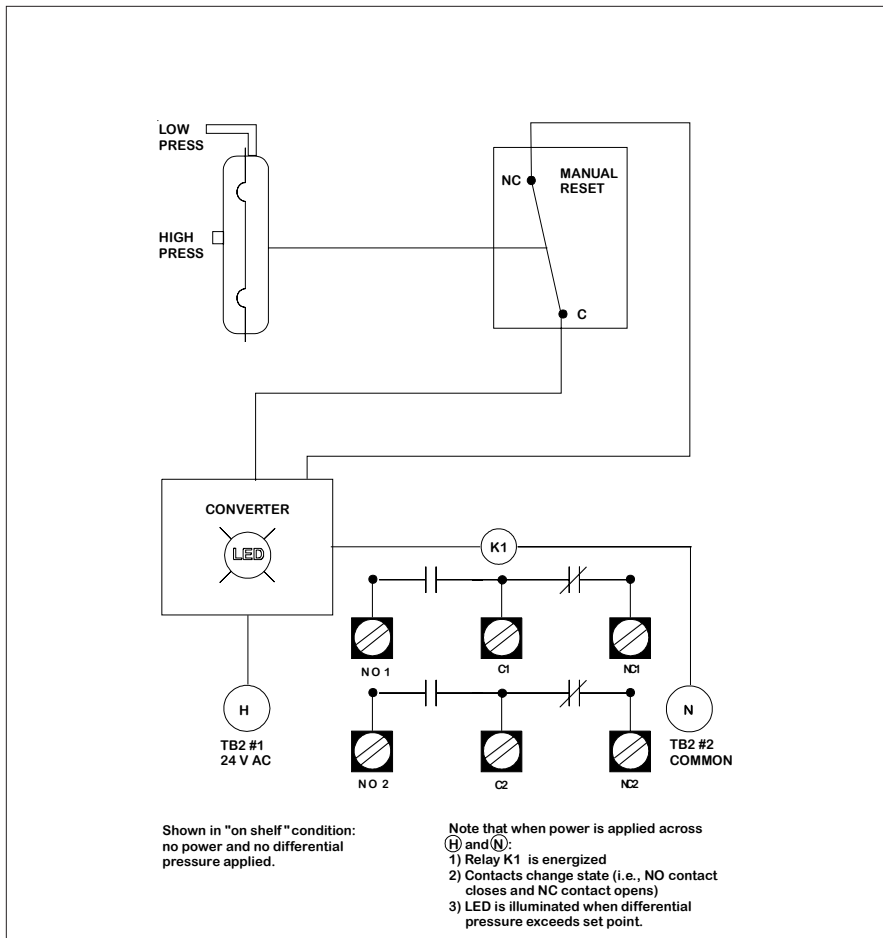

POSITIVE PRESSURE ONLY: Connect the sample line to inlet H; inlet L remains open to the atmosphere.

NEGATIVE PRESSURE ONLY: Connect the sample line to inlet L; inlet H remains open to the atmosphere.

TWO NEGATIVE SAMPLES: Connect the higher negative sample to inlet L. Connect the lower negative sample to inlet H.

TWO POSITIVE SAMPLES: Connect the higher positive sample to inlet H. Connect the lower positive sample to inlet L.

ONE POSITIVE AND ONE NEGATIVE SAMPLE: Connect the positive sample to inlet H. Connect the negative sample to inlet L.

Electrical Connections (see Figure 3)

Before pressure is applied to the diaphragm, the snap switch contacts will be in the normally closed (NC) position. As differential pressure rises above the

field adjustable set point, the snap switch opens, de-energizing the coil on the slave relay, which activates the DPDT contacts. An LED indicates that the snap switch exceeds differential set point. It remains lit until the manual reset push button is depressed.

Field Adjustment

The AFS-460-137 Manual Reset Air Switch has an adjustment range of 0.40 to 12.0" w.c., ± 0.06 " w.c. To adjust the set point:

Turn the adjusting screw counterclockwise until motion has stopped. Next, turn the adjusting screw 4 complete turns in a clockwise direction to engage the spring. From this point, the next ten turns will be used for the actual calibration. Each full turn represents approximately 1.16" w.c.

Please note: To properly calibrate an air switch, a digital manometer or other measuring device should be used to confirm the actual set point.

Specifications

Model AFS-460-137 Air Pressure Sensing Switch with manual reset feature, DPDT contact arrangement, for 24 VAC applications.

Sample Media: Air or combustion products that do not degrade silicone.

Mounting Position (in order to meet lowest operating specifications): Diaphragm in any vertical plane.

Field Adjustable Range: 0.40 \pm .06" w.c. to 12.0" w.c.

Switch Differential: Progressive, increasing from approximately .06 \pm .01" w.c. at minimum set point, to approximately .8" w.c. at maximum set point.

Maximum Pressure: 0.5 psi (0.03 bar)

Operating Temperature Range: -40 to 180F (-40 to 82C)

Electrical Rating: 0.5 VA @ 24 V AC, 50/60 Hz.

Contacts:

DPDT, 2 form-C rated 8 amp @ 250 V AC.

Electrical Connections: Screw terminals.

Sample Line Connections: Ferrule and nut compression type connectors will accept .25" OD rigid tubing.

Shipping Weight: 1.2 lbs.
Agency Approvals: pending

Pressure Conversion Table

1" H₂O = .0361 lbs./sq. in. or .0735 in. mercury
 1" Hg. = .491 lbs./sq. in. or 13.6 in. water
 1 psi = 27.7 in. water or 2.036 in. mercury

Accessories

- P/N 18311 Slip-on 1/4" OD Tubing Adapter, suitable for slipping on flexible plastic tubing.
- Sample line probes.
- Orifice plugs (pulsation dampers).