



# WI-SR65AKF

Wireless Duct Sensors (902MHz)



## Overview

Wireless and solar-cell powered airduct sensor for temperature control. Transmission to receiver by means of radio telegrams according to EnOcean standard. With integrated temperature sensor and solar energy storage for maintenance free operation.

## Applications

- Heating/Combustion systems

## Features & Benefits

- Wireless communication permits the optimization of sensor placement, easy relocation of sensors and switches, removes the need to open walls and extensive installation work
- Available in 902MHz
- Configurable via airConfig

## Model Selection

WI-SR65AKF100-902	Duct temperature sensor, 4" (100mm) length, wireless 902MHz, solar cell powered (optional battery available). Compatible with ECY, ECB, and ECL Open-to-Wireless ready controllers.
WI-SR65AKF150-902	Duct temperature sensor, 6" (150mm) length, wireless 902MHz, solar cell powered (optional battery available). Compatible with ECY, ECB, and ECL Open-to-Wireless ready controllers.
WI-SR65AKF200-902	Duct temperature sensor, 8" (200mm) length, wireless 902MHz, solar cell powered (optional battery available). Compatible with ECY, ECB, and ECL Open-to-Wireless ready controllers.

## Product Specifications

Technology	EnOcean (IEC 14543-3-10)
Transmitting frequency	902 MHz
Transmitting range	approx. 30m in buildings, approx. 300m upon free propagation
Temperature detection	Range: +50 to +194 °F, Configured via airConfig
Resolution	0,31 K
Accuracy	±1% of measuring range (typ. at 70 °F)
Transmission interval	configured via airConfig, Default: Wake-up time =100 sec. Heartbeat cycle = 10x
Energy generator	Solar cell, internal goldcap, maintenance-free
<input type="checkbox"/> Optional battery 3,6V Type LS14250, operation time with battery operation approx. 5 to 10 years (depending on the intentional component aging and the selfdischarging of the battery used).	
Enclosure	Bottom part: material PA6, colour white Top cover: Material PC, colour transparent Quick-lock screws
Protection	IP65 according to EN60529
Ambient conditions	-13 to +149 °F, max. 85% rH, short term condensation
Pocket	Stainless steel 1.4571, Ø=0,28 in.

## Norms and Standards

CE-Conformity	2004/108/EG Electromagnetic compatibility R&TTE 1999/5/EC Radio and Telecommunications Terminal Equipment Directive
Product safety	2001/95/EG Produktsicherheit
Standards	ETSI EN 301 489-1: 2001-09 ETSI EN 301 489-3: 2001-11 ETSI EN 61000-6-2: 2002-08 ETSI EN 300 220-3: 2000-09
Product safety	EN 60730-1:2002

FCC ID: S3N-SRXX This device complies with Part 15 of the FCC Rules.

Operation is subject to the following two conditions:

- (1) this device may not cause harmful interference
- (2) this device must accept any interference received, including interference that may cause undesired operation.

# Information on Wireless Sensors

## Transmission Range

As the radio signals are electromagnetic waves, the signal is damped on its way from the sender to the receiver. That is to say, the electrical as well as the magnetic field strength is removed inversely proportional to the square of the distance between sender and receiver ( $E, H \sim 1/r^2$ ).

Beside these natural transmission range limits, further interferences have to be considered: Metallic parts, e.g. reinforcements in walls, metallized foils of thermal insulations or metallized heat-absorbing glass, are reflecting electromagnetic waves. Thus, a so-called radio shadow is built up behind these parts.

It is true that radio waves can penetrate walls, but thereby the damping attenuation is even more increased than by a propagation in the free field.

Penetration of radio signals:

<u>Material</u>	<u>Penetration</u>
Wood, gypsum, glass uncoated	90 to 100%
Brick, pressboard	65 to 95%
Reinforced concrete	10 to 90%
Metall, aluminium pasting	0 to 10%

For the practice, this means, that the building material used in a building is of paramount importance for the evaluation of the transmitting range. For an evaluation of the environment, some guide values are listed:

Radio path range/-penetration:

- Visual contacts: Typ. 30m range in passages, corridors, up to 100m in halls
- Rigypsum walls/wood: Typ. 30m range through max. 5 walls
- Brick wall/Gas concrete: Typ. 20m range through max. 3 walls
- Reinforced concrete/-ceilings: Typ. 10m range through max. 1 ceiling Supply blocks and lift shafts should be seen as a compartmentalization

In addition, the angle with which the signal sent arrives at the wall is of great importance. Depending on the angle, the effective wall strength and thus the damping attenuation of the signal changes. If possible, the signals should run vertically through the walling. Walling recesses should be avoided.

# Dimensions

In inches (in)

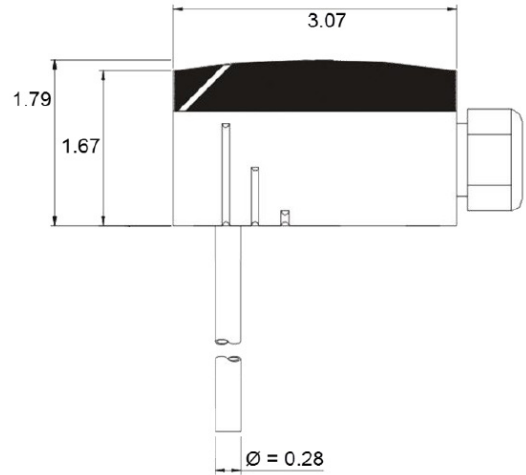
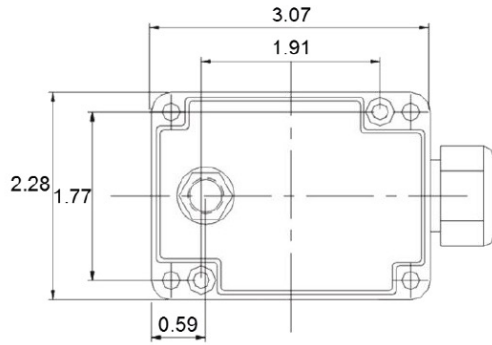

Specifications subject to change without notice.  
ECLYPSE, Distech Controls, and the Distech Controls logo are trademarks of Distech Controls Inc. All other trademarks are property of their respective owner.  
©, Distech Controls Inc., 2014. All rights reserved.