

M9000-300

Weather Shield Enclosure



M9000-300

Shown Mounted on a Control Damper

Description

The M9000-300 Weather Shield Enclosure is a cost effective and rugged weather shield designed to protect M9000 actuators in outdoor damper applications. The weather shield enclosure is designed to NEMA 4 specifications, and does not allow any moisture to penetrate the custom designed seals.

The weather shield cover is constructed of a sturdy ABS material injected with ultraviolet inhibitors, which prevents the cover from

becoming brittle or damaged by the sun or any other outdoor element. In addition, this translucent material allows the actuator to be fully viewable. It includes a gasket, damper bracket, anti-rotation bracket, anti-rotation pin, and a liquid tight conduit connector. The base is constructed of a durable nylon blend that provides flexibility and durability.

For more information on the actuators, refer to the appropriate literature: *M9108, M9116, M9124, and M9132 Series Electric Non-spring Return Actuators Installation Instructions, Part No. 34-636-399*; *M9109 Series Electric Non-spring Return Actuators Installation Instructions, Part No. 34-636-1190*; *M9216 Series Electric Spring Return Actuators Installation Instructions, Part No. 34-636-461*; *M9106-xGx-2 Series Electric Non-spring Return Actuators Installation Instructions, Part No. 34-636-1085*; or the *M9206 Series Electric Spring Return Actuators Installation Instructions, Part No. 34-1280-9*.

Applications

For more information, refer to the *M9000-300 Weather Shield Enclosure Product/Technical Bulletin, LIT-10000055*.

Features

- durable construction provides protection for the actuator and is able to withstand outdoor elements
- cost effective method of enclosure allows a NEMA 2 instead of a NEMA 4 actuator to be used in outdoor applications
- easy installation makes previously installed actuators easy to enclose
- translucent ABS material allows the actuator to be viewable without disassembling the weather shield enclosure

To Order

To order a weather shield enclosure, contact the nearest Johnson Controls representative, and specify product code number **M9000-300**.

Accessories

Code Number	Description
M9000-301	Damper bracket (steel, zinc coated) measuring 14.00 x 0.75 x 0.08 in. (355.6 x 19.05 x 2.03 mm); Shipping weight: 3.1 lb (1.4 kg)
M9000-302	Standard Heater Kit measuring 2.0 x 1.0 x 0.5 in. (50.8 x 25.4 x 12.7 mm); 12 to 36 VAC/VDC, 10 W; Shipping weight: 1.40 lb (0.64 kg)
M9000-303	Tropical Heater Kit measuring 2.4 x 1.0 x 0.5 in. (61.0 x 25.4 x 12.7 mm); 12 to 36 VAC/VDC, 10 W; Shipping weight: 1.40 lb (0.64 kg)

Specifications

M9000-300 Weather Shield Enclosure	
Material	Top: ABS; Bottom: Nylon blend
Enclosure	NEMA 24, IP55
Dimensions (H x W x D)	8.04 x 14.50 x 7.17 in. (204.2 x 368.3 x 182.1 mm)
Shipping Weight	4.0 lb (1.8 kg)

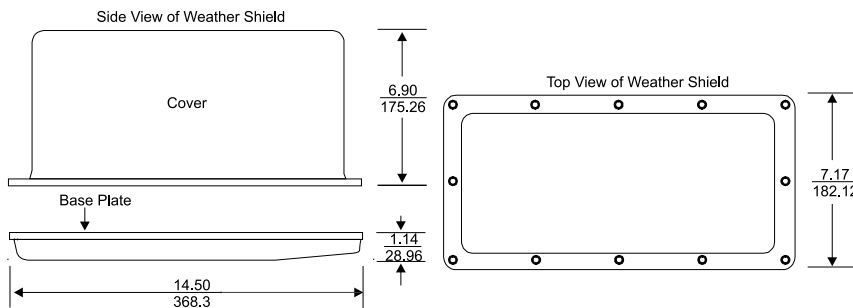

Dimensions, in. (mm)