

A350P Series

Electronic Proportional Plus Integral Temperature Control

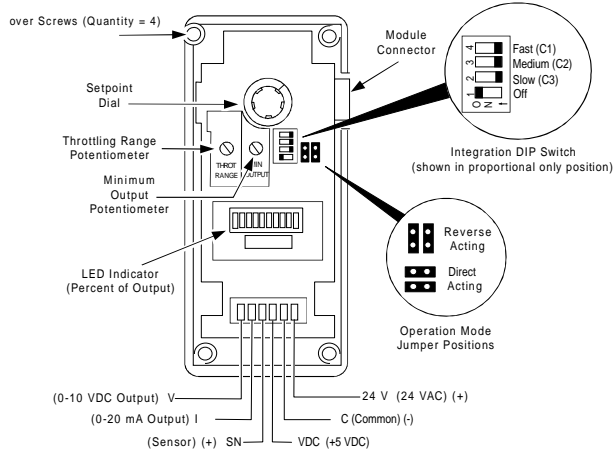

A350P



Features

- field-selectable proportional only or proportional plus integral control
- plug-together connectors and 35 mm DIN rail mounting eliminate wiring between models and reduce installation costs
- ten segment LED displays percent of output signal
- field-selectable reverse or direct-acting mode
- minimum output adjustable from 0 to 60%
- two models cover a wide setpoint range of -30 to 250°F (-35 to 121°C)

Applications

- modulating heating and cooling valves
- maintain mixed air duct temperature via damper modulation

To Order

Specify code number from the selection chart, along with additional staging, power and display modules, and temperature sensing enclosures, if required.

Description

The A350P Electronic Proportional Plus Integral Temperature Control Series has two proportional outputs of 0 to 10 VDC and 0 to 20 mA. This control is used in conjunction with the A99B Series (PTC silicon) Temperature Sensors. Two controls cover a temperature range from -30 to 250°F with an adjustable throttling range (proportional band) of 2 to 30F°.

Proportional plus integral (PI) control is an option to hold setpoint regardless of load shifts on the system. A temperature sensor (A99BC-25C) is included with each A350P control. The S350 Staging Module, D350 Display Module, and Y350R Power Module can be used with the A350P.

Selection Chart

Code Number	Output Signal	Range	Throttling Range	Sensor (Included)
A350PS-1C	Proportional Voltage: 0 to 10 VDC and and	-30 to 130°F	2 to 30F°	A99BC-25C
A350PT-1C		-35 to 55°C		None
A350PS-2C	Proportional Current: 0 to 20 mA	90 to 250°F	1 to 17C°	A99BC-25C
		30 to 121°C		

Specifications

A350P Electronic Temperature Control with Proportional Output	
Supply Voltage (a)	Transformer 20 to 30 VAC, 50/60 Hz, Class 2 Y350R 120/240 VAC, 50/60 Hz
Proportional Output	0 to 10 VDC (550 ohm load minimum) and 0 to 20 mA. (600 ohm load maximum).
Minimum Output	Adjustable from 0 to 60% of the output span
Output Indication	A ten segment LED indicates percentage of output
Control Action	Direct or reverse action is jumper selectable
Power Consumption	3.2 VA
Integration Constant	Three selectable rates fast, medium, slow and an Off position
Ambient Temperature	Operating -30 to 150°F (-34 to 66°C) Shipping -40 to 185°F (-40 to 85°C)
Humidity	0 to 95% RH non-condensing
Case and Cover Material	NEMA 1, high-impact thermoplastic

(a) Only one voltage source may be used.

A350P Dimensions, in. (mm)

