

CLEVELAND CONTROLS

# Sensing Probes

for Air Pressure Sensing Switches

STATIC PRESSURE PROBES				
Dimension A	Smooth OD Dimension B	Part Number	Barbed End Dimension B	Part Number
1.5	1.0	21397	1.75	21397-112
2.0	.5	21116	1.25	21116-112
3.5	1.0	21398	1.75	21398-112
4.0	.5	21117	1.25	21117-112
5.5	1.0	21399	1.75	21399-112
6.0	.5	21118	1.25	21118-112
7.5	1.0	21400	1.75	21400-112
8.0	.5	21119	1.25	21119-112

TOTAL PRESSURE (IMPACT) PROBES				
Dimension A	Smooth OD Dimension B	Part Number	Barbed End Dimension B	Part Number
1.5	1.0	21401	1.75	21401-112
2.0	.5	21120	1.25	21120-112
3.5	1.0	21402	1.75	21402-112
4.0	.5	21121	1.25	21121-112
5.5	1.0	21403	1.75	21403-112
6.0	.5	21122	1.25	21122-112
7.5	1.0	21404	1.75	21404-112
8.0	.5	21123	1.25	21123-112
10.0	.5	28527	1.25	28527-112
12.0	.5	28528	1.25	28528-11

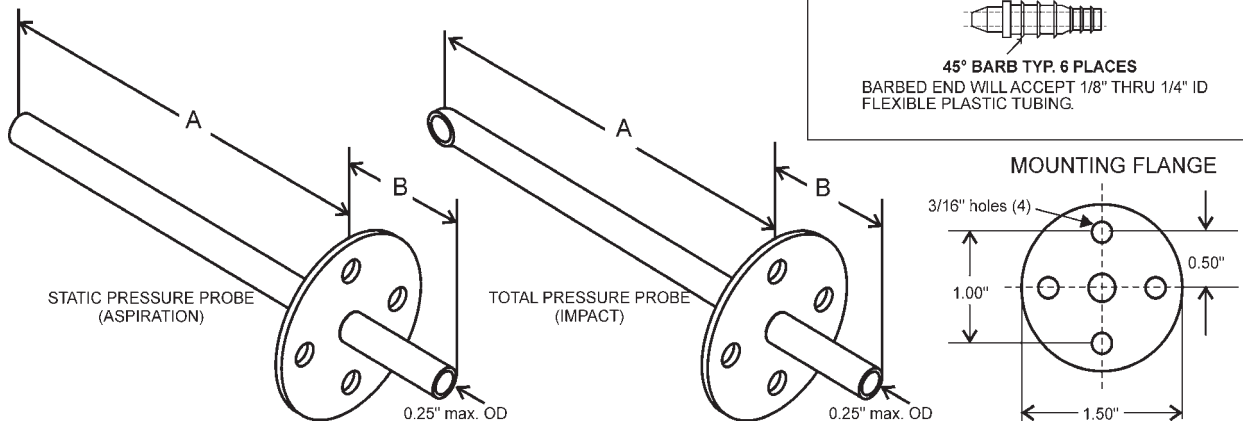

**Recommended probe locations:**

- Position 5 to 8 diameters downstream from elbows, obstructions, or large change in duct area.
- Insert probe into duct perpendicular to airstream so that:
  - **Aspiration** (static) probe tip opens parallel with airstream.
  - **Impact** (total pressure) probe tip opens directly into the airstream.

**Typical applications (see illustration):**

- Positive static pressure increases as the filter gets dirty.
- Differential across filter changes as filter gets dirty.
- Flow is reduced as filter gets dirty.
- Fan operation or true air flow with little or no static pressure.
- Negative pressure increases as the filter gets dirty.
- Fan operation and true air flow: varying amounts of static pressure. Probes must be perpendicular to air flow.

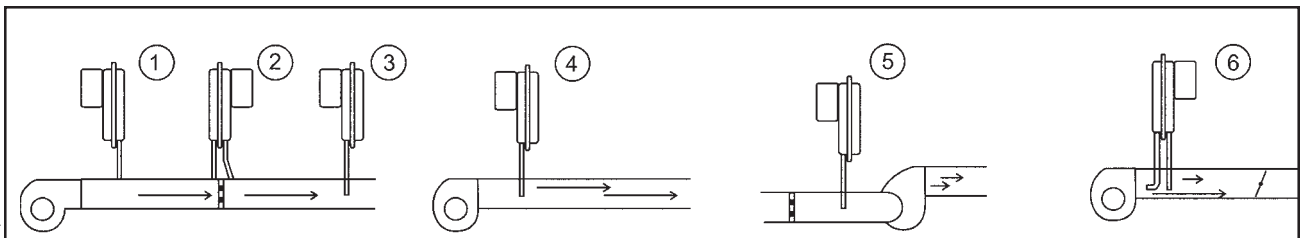

**Cleveland Controls**  
Division of UniControl Inc.

1111 Brookpark Road • Cleveland OH 44109

TEL: (216) 398-0330 • FAX: (216) 398-8558 <http://www.clevelandcontrols.com>

Bulletin AFS05.03