

<http://www.functionaldevices.com>

MH3300 SERIES

Metal Housing, NEMA 1, 12.5" H x 12.5" W x 7" D



Functional Devices, Inc. A600A 2003

GENERAL SPECIFICATIONS

Construction: 18 Gauge Steel
Weight: 9.1 lbs.
Cover Type: Hook Hinge Screw Down Cover
Approvals: UL Listed, C-UL Canada

(Shown with Options)

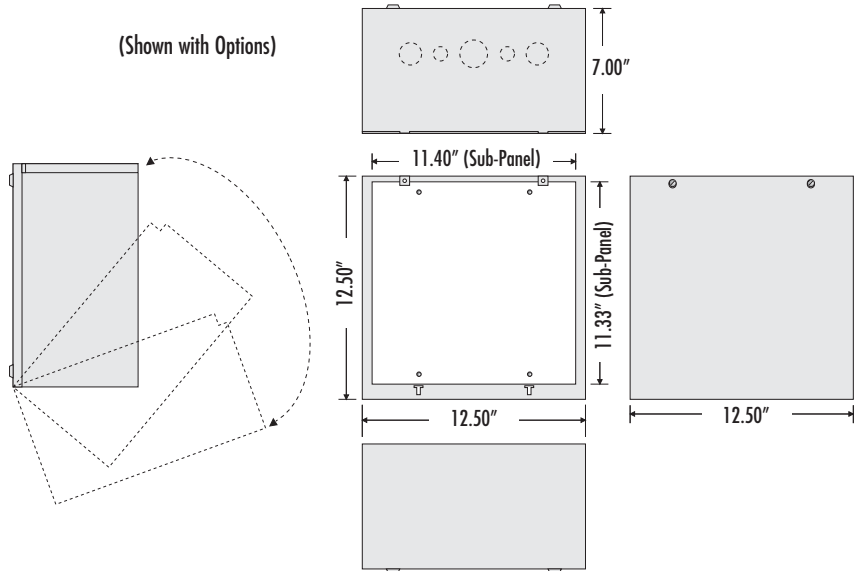

MH3300 SERIES SELECTION GUIDE

Model #	=	Enclosure	+	Sub-Panel
MH3303		MH3300		SP3303

See "Accessories" section for mounting track

NOTES: