

M9000-300 Weather Shield Enclosure

The M9000-300 Weather Shield Enclosure is a cost effective and rugged weather shield designed to protect M9000 actuators in outdoor damper applications. The weather shield enclosure is designed to NEMA 4 specifications, and does not allow any moisture to penetrate the custom-designed seals.

The weather shield cover is constructed of a sturdy ABS material injected with ultraviolet inhibitors, which prevents the cover from becoming brittle or damaged by the sun or any other outdoor element. In addition, this translucent material allows the actuator to be fully viewable. It includes a gasket, anti-rotation bracket, anti-rotation pin, damper bracket, and a liquid-tight conduit connector. The base is constructed of a durable nylon blend that provides flexibility and durability.



Figure 1: M9000-300 Shown Mounted on a Control Damper

| Features and Benefits | |
|--|---|
| <input type="checkbox"/> Durable Construction | Provides protection for the actuator; able to withstand outdoor elements |
| <input type="checkbox"/> Cost Effective Method of Enclosure | Allows NEMA 2 instead of NEMA 4 actuator use in outdoor applications |
| <input type="checkbox"/> Easy Installation | Makes previously installed actuators easy to enclose |
| <input type="checkbox"/> Translucent ABS Material | Allows the actuator to be viewable without disassembling the weather shield enclosure |

Dimensions

See Figure 2 for the M9000-300 dimensions.

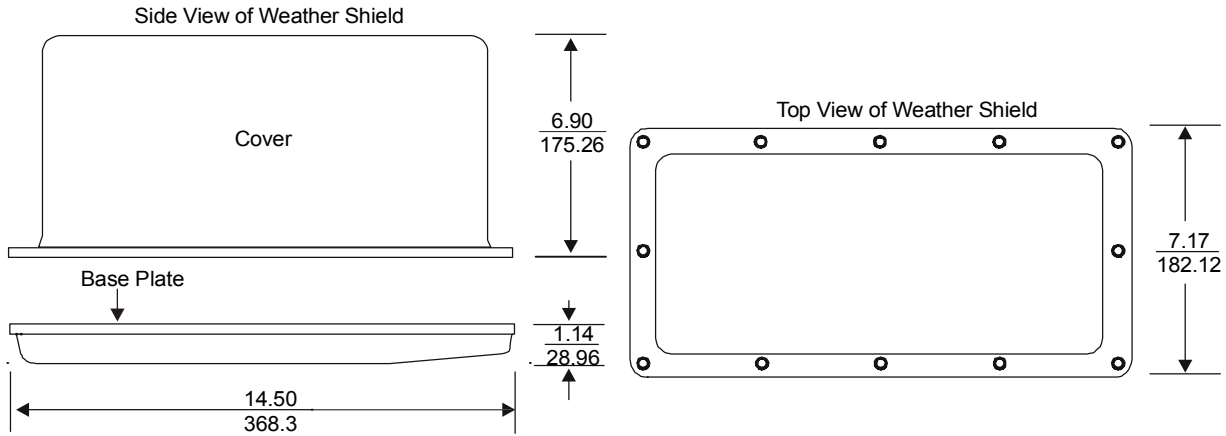

Figure 2: Weather Shield Enclosure Dimensions, in. (mm)

Installation

For more information on the actuators, refer to the appropriate literature: *M9108, M9116, M9124, and M9132 Series Electric Non-spring Return Actuators Installation Instructions (Part No. 34-636-399)*; *M9109 Series Electric Non-spring Return Actuators Installation Instructions (Part No. 34-636-1190)*, *M9216 Series Electric Spring Return Actuators Installation Instructions (Part No. 34-636-461)*; *M9106-xGx-2 Series Electric Non-spring Return Actuators Installation Instructions, (Part No. 34 636-1085)*; or the *M9206 Series Electric Spring Return Actuators Installation Instructions (Part No. 34-1280-9)*.

Parts Included

- M9000-300 with a gasket
- No. 10-32 x 3/8 in. screw (16)
- anti-rotation bracket for M9206 actuator
- anti-rotation pin
- damper bracket
- liquid-tight conduit connector

In humidity prone areas that cause condensation inside of the weather shield enclosure, order the appropriate heater/thermostat from Table 1 and mount inside of the enclosure.

Special Tools Needed

- No. 1 Phillips screwdriver
- 1/2 in. liquid-tight conduit and fittings to terminate wiring (size length for the application)

Mounting

The M9000-300 is fully assembled with the cover held in place with two No. 10-32 x 3/8 in. screws. The remainder of the parts are included inside of the M9000-300 enclosure.

To install the M9000-300, proceed as follows:

1. Remove the screws from the cover, and remove the cover from the base plate and the gasket. (See Figure 3.)

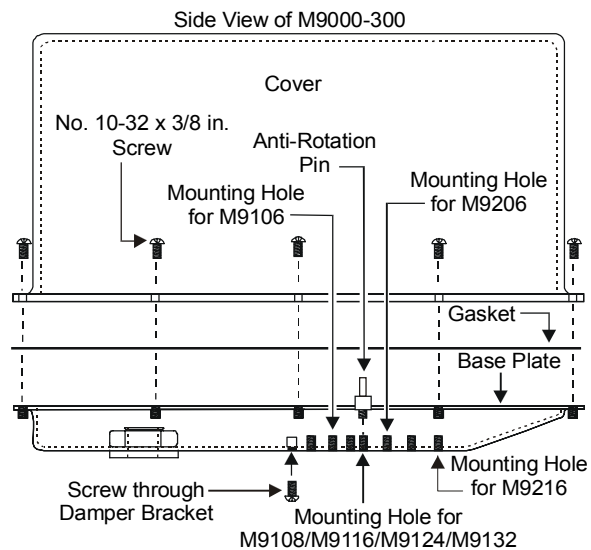

Figure 3: Components of the M9000-300

2. Install the anti-rotation pin or bracket in the appropriate hole to accommodate the M9000 actuator used. (See Figure 4.)

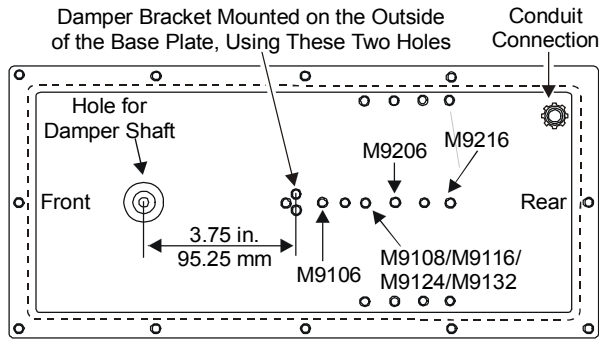

Figure 4: Mounting the Actuator to the Base Plate

3. Position the slot at the bottom of the actuator onto the groove of the anti-rotation pin or bracket.

Note: If the anti-rotation pin or bracket was installed in the correct hole for the actuator (shown in Figure 4), the hole for the damper shaft in the base plate should align with the damper shaft opening in the actuator coupler. If not, repeat Steps 2 and 3.

4. Position the actuator and the base plate of the enclosure over the damper shaft and onto the damper assembly.
5. Make sure the actuator is at 0 volts.
6. Refer to Figure 3, and secure the damper bracket shown in Figure 5 to the base plate of the enclosure, using two No. 10-32 x 3/8 in. screws provided. (See Figure 4 for the location of the holes in the base plate.)



Figure 5: Installing the Damper Bracket

Note: For detailed information on installing an M9000 actuator, refer to the appropriate piece of literature listed previously.

7. Feed the cable from the actuator through the liquid-tight conduit connector.
8. Add field supplied 1/2 in. liquid-tight conduit and fittings as needed to complete the installation.
9. Place the gasket on the cover, and secure to the M9000-300 by inserting the remaining No. 10-32 x 3/8 in. screws through the cover and the gasket.
10. Place the cover assembly onto the enclosure base plate, and tighten the screws to hold the enclosure in place.

Repairs and Replacement

Field repairs must not be made. To order a replacement or an accessory, refer to the *Ordering Information* section.

Ordering Information

Contact the nearest Johnson Controls representative, and specify the desired product code number from Table 1.

Table 1: Products and Accessories

| Product Code Number | Description |
|---------------------|---|
| M9000-300 | Weather Shield Enclosure (includes a gasket, anti-rotation pin, anti-rotation bracket, damper bracket, and conduit connector) |
| M9000-301 | Damper bracket (steel, zinc coated) measuring 14.00 x 0.75 x 0.08 in. (355.6 x 19.05 x 2.03 mm); Shipping weight: 3.1 lb (1.4 kg) |
| M9000-302 | Standard Heater/Thermostat measuring 2.0 x 1.0 x 0.5 in. (50.8 x 25.4 x 12.7 mm); 12 to 36 VAC/VDC, 10 W; operates at 41°F (5°C) and shuts off at 59°F (15°C); shipping weight: 1.40 lb (0.64 kg). Intended for applications in regions with an expected dew point of 39°F (4°C) or lower. |
| M9000-303 | Tropical Heater/Thermostat measuring 2.4 x 1.0 x 0.5 in. (61.0 x 25.4 x 12.7 mm); 12 to 36 VAC/VDC, 10 W; operates at 86°F (30°C) and shuts off at 104°F (40°C); shipping weight: 1.40 lb (0.64 kg). Intended for applications in regions with an expected dew point of 81°F (27°C) or lower. |

Technical Data

| | | | |
|-------------------------------|--|---------|-------------|
| Product | M9000-300 Weather Shield Enclosure | | |
| Material | Top: ABS | Bottom: | Nylon blend |
| Enclosure | NEMA 4, IP55 | | |
| Dimensions (H x W x D) | 8.04 x 14.50 x 7.17 in. (204.2 x 368.3 x 182.1 mm) | | |
| Shipping Weight | 4.0 lb (1.8 kg) | | |

The performance specifications are nominal and conform to acceptable industry standards. For application at conditions beyond these specifications, consult the local Johnson Controls office. Johnson Controls, Inc. shall not be liable for damages resulting from misapplication or misuse of its products.



Controls Group
507 E. Michigan Street
P.O. Box 423
Milwaukee, WI 53201

Printed in U.S.A.
www.johnsoncontrols.com