

## R310A Series Current Sensing Switch

*The R310A Series Current Sensing Switch detects current flow in a circuit without being wired to that circuit. It may be used in any application where current detection is required.*

*The R310A switch replaces the R10A Current Sensing Relay and is typically used with Johnson Controls time delay oil failure cutout controls such as the P28, P45, and P445 lube oil controls. The R310A is used to reduce nuisance lube oil protection lockout caused by compressor motor overloads in applications where lockout due to overload cycling is not desirable.*

*The R310A switch is molded in a high dielectric material, which permits mounting inside a motor starter or contactor enclosure.*



**Figure 1: R310A Series Current Sensing Switch**

### Features and Benefits

<input type="checkbox"/> <b>Small Size</b>	Allows mounting in small enclosure
<input type="checkbox"/> <b>Solid-state Switch</b>	Contains no moving parts to fail
<input type="checkbox"/> <b>Low Amperage Switch Activation</b>	Allows continuous sensing of current for most small equipment circuit loads
<input type="checkbox"/> <b>200 Ampere Maximum Sensing Capacity</b>	Allows continuous sensing of current to heavy duty equipment
<input type="checkbox"/> <b>Large 11/16 in. (18 mm) Diameter Sensor Hole</b>	Accepts large diameter wire sizes and multiple coils of smaller diameter wire sizes

# Application

**IMPORTANT:** The R310A Current Sensing Switch is designed to control equipment under normal operating conditions. Where failure or malfunction of the switch could lead to an abnormal operating condition that could cause personal injury or damage to the equipment or other property, other devices (limit or safety controls) or systems (alarm or supervisory systems) intended to warn of or protect against failure or malfunction of the switch must be incorporated into and maintained as part of the control system.

**IMPORTANT:** The R310A Current Sensing Switch is not intended to detect breakage of belts, shafts, or fan blades.

The R310A switch is designed to sense current in a conductor that passes through its open core and close an electronic switch if the current through the conductor exceeds the switch's minimum amperage rating. See *Specifications*.

Typical applications are:

- switching a pilot circuit
- interlocking compressor operation with lube oil protection devices
- detecting compressor operation on Heating, Ventilating, Air Conditioning, or Refrigeration (HVAC/R) equipment
- detecting the presence of electrical loads
- detecting on/off status of process motors

The R310A Series Current Sensing Switch is available in two models. The R310AD-1 switch is used to switch low-voltage control circuits, such as the P445 Electronic Lube Oil Control delay timer circuit. The R310AE-2 switch is used to switch high-voltage control circuits, such as the P28 and P45 Electromechanical Lube Oil Controls time delay heater circuit.

Johnson Controls/PENN oil failure cutout controls incorporate a time delay heater (P28 and P45 lube oil controls) or an electronic timer (P445 electronic lube oil control), which must be de-energized when the compressor shuts down due to the compressor motor overload protection device. If the timing circuit in the oil failure cutout control is not de-energized, the control locks out and gives false indication of lube oil problems.

In a typical compressor application, the 3-phase motor leads (T<sub>1</sub>, T<sub>2</sub>, T<sub>3</sub>) are connected to the power source through a contactor or motor starter. During normal operation, the contactor is closed on demand for cooling and opened when the cooling demand is met.

If the compressor motor overheats and an internal thermal overload circuit opens, the compressor stops running, but the contactor may remain closed. Compressor shutdown causes the oil pressure to drop, and the heater (P28 or P45 lube oil control) or the timer (P445 electronic lube oil control) is energized, which results in a nuisance lockout and false indication of a lube oil problem.

The R310A switch avoids these nuisance lockouts by sensing the lack of current flow to the motor. Regardless of the reason for motor shutdown, the lube oil control time delay circuit is de-energized when the current flow in the motor supply line drops below the minimum amperage rating. See *Specifications*.

## Operation

One of the motor supply leads is passed through the opening in the R310A switch. A current flow of more than 0.5 ampere (R310AD-1) or 0.75 ampere (R310AE-2) in the motor supply lead closes the electronic switch. If the R310A switch is used with a lube oil control, this action energizes the lube oil control's heater (P28 or P45 lube oil control) or timer (P445 electronic lube oil control).

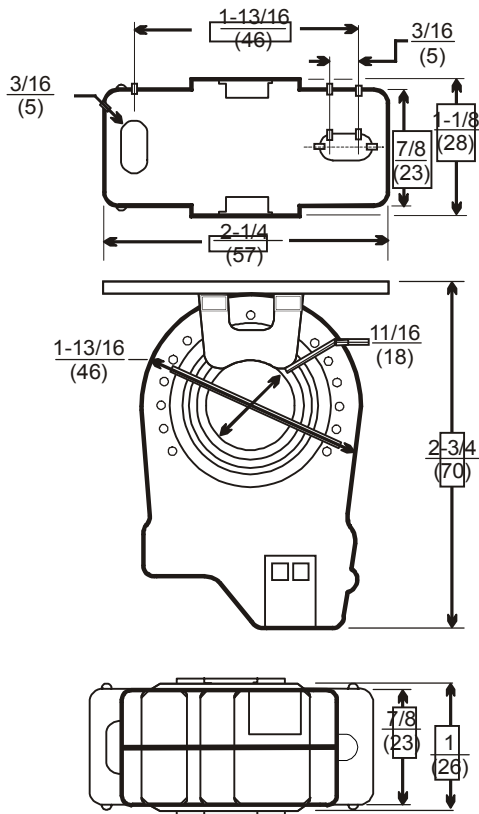

**Figure 2: R310A Series Switch and Mounting Bracket Dimensions, in. (mm)**

## Installation



**WARNING: Risk of Electrical Shock.**  
Disconnect power supply before making electrical connections to avoid possible electrical shock or equipment damage.

**IMPORTANT:** Verify that the power conductor to be monitored is disconnected from the power source before beginning installation. Failure to follow this precaution may result in undesired activation of the switch during the installation process.

Avoid wire strain on motor supply lead when locating and fastening the R310A switch.

The sensor may be located at any point on the conductor between the motor starter and the motor. Use the following procedure to install the R310A switch:

1. Pass the conductor through the center hole in the R310A switch.
2. Connect the conductor to the terminals on the motor starter or motor.
3. Fasten the mounting bracket (included) to a flat surface using the screws provided.
4. Snap the rounded end of the R310A switch into the mounting bracket.
5. If an electromechanical lube oil control is used, connect the R310A switch output to the heater timer circuit. (The R310A switch terminals are not polarity sensitive.) If the P445 control is used, connect the R310A switch output to terminals W1 and W2 on the P445 control.

## Low Amperage Applications

Applications where the sensed current is less than the switch's minimum rating require that the conductor to be wrapped through the center hole and around the sensor body to produce multiple loops. The use of multiple loops creates a magnetic field sufficient to close the electronic switch. In this case, the number of times the wire must pass through the center hole can be determined using a simple formula:

### Formula for R310AD-1 Switch

$$N = 0.5 / \text{Current}$$

### Formula for R310AE-2 Switch

$$N = 0.75 / \text{Current}$$

Round "N" up to the nearest whole number, if needed.

### Example

If the model used is an R310AD-1 switch and the current is 0.2A, then the equation becomes:

$$N = 0.5 / 0.2 = 2.5$$

Rounded up,  $N = 3$  and the wire needs to pass through the center hole three times. (See Figure 3.)

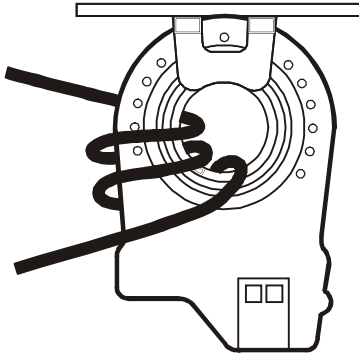

**Figure 3: Multiple Wiring Turns for Low Amperage Applications**

### High Amperage Applications

Applications where the sensed current may exceed 200A require the use of an appropriately sized external current transformer. Install the external current transformer on the conductor per the manufacturer's specifications. Run the current transformer's secondary wire through the R310A switch and connect the current transformer's secondary wires per the manufacturer's specifications and instructions.

### Wiring

Figure 4 shows typical high-voltage field wiring on a 240 VAC system with a P28 or a P45 lube oil control and an R310AE-2 switch. Figure 5 shows typical low-voltage field wiring on a 240 VAC system with a P445 electronic lube oil control and an R310AD-1 switch. In both illustrations, the conductor is passed through the opening in the R310A switch.

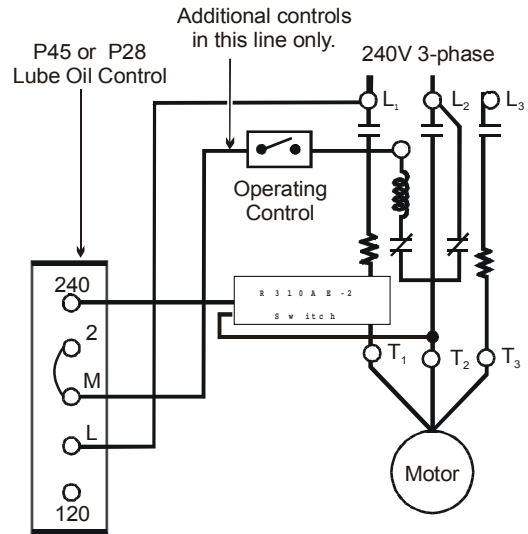

**Figure 4: Typical High-Voltage Field Wiring**

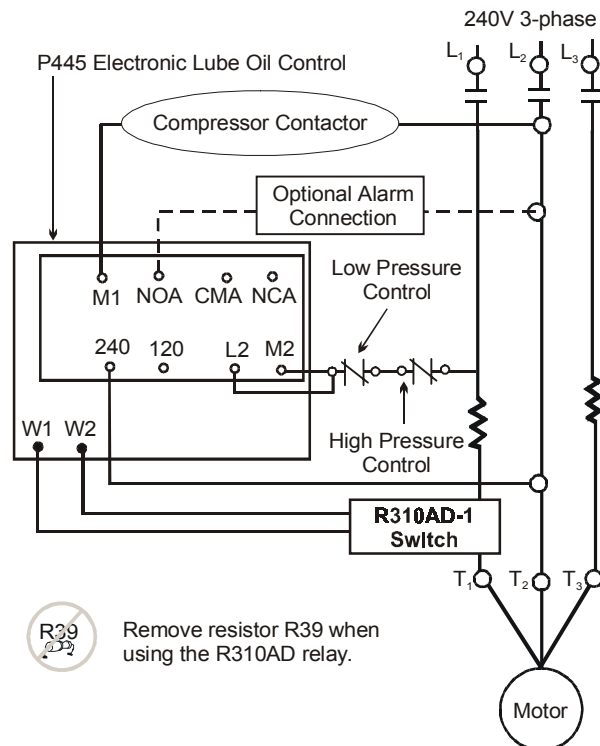

**Figure 5: Typical Low-Voltage Field Wiring**

## Testing

To test an R310A Current Sensing Switch for operation, use the following procedure:

1. Ensure that the R310A switch is connected to a load and power, but that no current is flowing through the conductor that passes through the R310A switch.
2. Use a voltmeter to measure the AC or DC voltage across the terminals of the R310A switch. The meter should read the same as the power.
3. Apply current to the conductor that passes through the center hole of the R310A switch.
4. Use a voltmeter to measure the AC or DC voltage across the terminals of the R310A switch. The meter should read minimal or no voltage.
5. Compare the readings. If the first reading detected a voltage equal to the power and the second reading detected minimal or no voltage, then the R310A switch is operating properly. If any other result was found, the R310A switch is not operating properly and should be replaced.

## Repairs and Replacement

Field repairs must not be made. For a replacement current sensing switch, contact the nearest Johnson Controls/PENN distributor.

## Ordering Information

**Table 1: Ordering Information**

Product Code Number	Description
<b>R310AD-1C</b>	Current Sensing Switch Voltage Switching Rating: 0-30V AC/DC
<b>R310AE-2C</b>	Current Sensing Switch Voltage Switching Rating: 0-250V AC/DC

---

## Notes

---

## Notes

# Specifications

<b>Product</b>	R310A Series Current Sensing Switch
<b>Switch Action</b>	Solid State, Normally Off
<b>Current Sensing Range</b>	R310AD-1 Switch: 0.5-200 Amperes R310AE-2 Switch: 0.75-200 Amperes
<b>Switch Threshold</b>	R310AD-1 Switch: 0.5 Ampere R310AE-2 Switch: 0.75 Ampere
<b>Sensor Supply Voltage</b>	Induced from Monitored Conductor, Isolation 600 VAC RMS
<b>Switching Capacity (General Purpose)</b>	R310AD-1 Switch: 0.1A @ 30 VAC/DC R310AE-2 Switch: 0.5A @ 250 VAC/DC
<b>Output Polarity</b>	Non-polarity Sensitive Output
<b>Enclosure</b>	NEMA 1
<b>Agency Listings</b>	UL File, E190934; CCN's NRNT (US) and NRNT7 (Canada)
<b>Ambient Operating Conditions</b>	R310AD-1 Switch: 5 to 140°F (-15 to 60°C); 0-95% RH, Non-condensing R310AE-2 Switch: 5 to 122°F (-15 to 50°C); 0-95% RH, Non-condensing
<b>Ambient Storage Conditions</b>	-40 to 158°F (-40 to 70°C); 0-95% RH
<b>Dimensions (H x W x D)</b>	2.34 x 1.85 x 0.875 in. (59 x 46 x 22 mm)
<b>Sensor Hole Size</b>	0.70 in. (17 mm) Diameter
<b>Shipping Weight</b>	0.60 lb (0.27 kg)

*The performance specifications are nominal and conform to acceptable industry standards. For application at conditions beyond these specifications, consult Johnson Controls/PENN Application Engineering at (800) 275-5676. Johnson Controls, Inc. shall not be liable for damages resulting from misapplication or misuse of its products.*



**Controls Group**  
507 E. Michigan Street  
P.O. Box 423  
Milwaukee, WI 53201

[www.johnsoncontrols.com](http://www.johnsoncontrols.com)  
Printed in U.S.A.