

## P28 and P128 Series Lube Oil Controls with Built-in Time Delay Relay

The P28 and P128 Series Lube Oil Controls provide dependable and economical oil pressure cut-out for pressure-lubricated refrigeration compressors. The field-adjustable pressure differential of these controls provides compressor operation according to the manufacturer's specifications. The P28 and P128 controls operate by measuring the net lube oil pressure and de-energizing the compressor if the pressure falls below the differential setpoint.

Manual or automatic reset models are available with factory set and sealed time delays of 30, 45, 60, 90, or 120 seconds (all time delays may not be available on all models). The P128 is the same control as the P28 but with 1/4 inch male flare pressure connections.



Figure 1: P128AA

Features and Benefits	
<b>Built-in Time Delay Relay with Ambient Compensation</b>	Minimizes timing fluctuations due to temperature variations
<b>Trip-free Manual Reset</b>	Provides manual reset that cannot be overridden by pressing and holding the reset button
<b>Replaceable Time Delay Relay Assembly</b>	Allows easy field replacement of the time delay relay and terminal board
<b>Available with Runlight and Alarm Terminals</b>	Allows the control to be wired for normal oil pressure runlight signals and shutdown alarm circuits for remote monitoring of oil pressure status

## Introduction



**WARNING: Personal injury hazard.** All P28 and P128 controls are designed as lubrication protection controls. Failure of the P28 or P128 could allow the refrigeration compressor to be damaged in a way that may not be apparent upon visual inspection. Follow proper procedures and the compressor manufacturer's instructions, as well as any warning signs on or around the equipment, when discharging and disassembling the compressor.

**Environmental damage hazard.** If leakage of sensed media (such as refrigerant or oil) can be harmful to the environment, or hazardous in any way, user must provide for proper containment.

The P28 and P128 controls measure the net oil pressure available to circulate oil throughout a pressure-lubricated refrigeration system. The net oil pressure is the difference between the oil pressure at the pump discharge and the refrigerant pressure in the compressor crankcase.

Example: If the oil pressure pump discharge reading is 90 psi (621 kPa) and the crankcase pressure is 70 psi (483 kPa), the net oil pressure is 20 psi (138 kPa).

The P28 and P128 have a built-in time delay relay. This relay allows the oil pressure to build up for the time delay period before the compressor trips. This also prevents nuisance lockouts due to intermittent loss of oil pressure. The time delay relay is a "trip free" device. The manual reset cannot be overridden by pressing and holding the reset button.

Manual reset models are available with time delays of 30, 45, 60, 90, or 120 seconds. Automatic reset models are available with a 90-second time delay. The time delay relay is compensated to minimize the effect of ambient temperature variations. However, the time delay relay will be affected by voltage variations.

## Dimensions

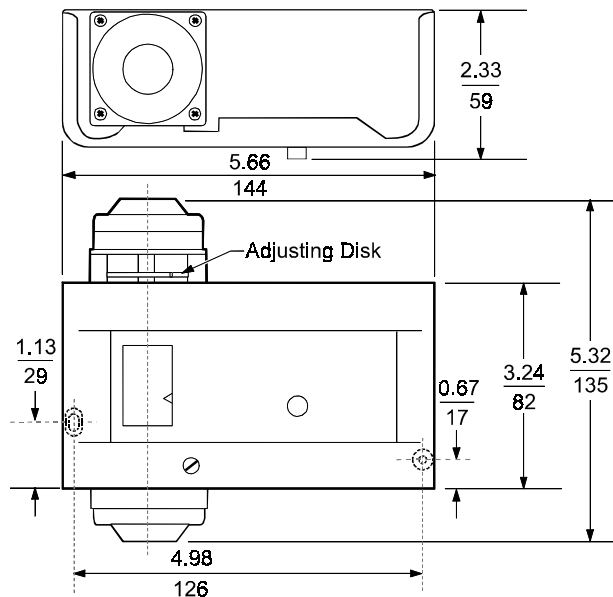

Figure 2: P28 or P128 Dimensions (in./mm)

## Operation

When the compressor starts, the timer is energized because the net oil pressure of the system is zero. During normal operation, the net oil pressure should build up to the pressure switch's cut-out setting (scale setting) plus the switch differential (3 to 5 psi [21 to 34 kPa]) within the required time delay, causing the time delay relay to de-energize.

If the net oil pressure does not rise to the cut-out pressure setting plus the switch differential within the required time delay, the time delay relay trips and stops the compressor.

If the net oil pressure drops below the cut-out pressure setting during the compressor's run cycle, the time delay relay energizes. If the net oil pressure returns within the time delay, the time delay relay de-energizes and the compressor continues to operate normally. If the net oil pressure does not return within the time delay, the control shuts down and locks out the compressor.

Example: Net oil pressure (oil pump pressure minus crankcase pressure) required to the bearings is 9 psi (62 kPa). The control scale setting should be 9 psi (62 kPa). The switch differential is 5 psi (34 kPa). Upon initial start of the compressor, the time delay relay energizes. If the net oil pressure does not build up to 14 psi (97 kPa), or the scale setting (9 psi) plus the switch differential (5 psi), during the time delay, the control breaks the circuit to the compressor. If the pressure of 14 psi (97 kPa) is reached during the time delay, the time delay relay de-energizes and the compressor continues to operate normally.

## Installation

### Mounting



**CAUTION: Equipment damage hazard.**

- A P28AN or P28DN control used for ammonia service must be mounted separately from the electrical cabinet. An ammonia leak could damage the electrical circuitry.
- Do not use Johnson Controls/Penn Ecosafe® hose tubing in applications with ammonia or other corrosive refrigerants. Corrosion could cause tube breakage and refrigerant leakage.
- Use **only** the mounting screws supplied with the control. Damage to internal components may occur if other screws are used.

The P28 and P128 controls are not position sensitive and can be mounted in any position.

Use the two mounting screw holes located on the back of the control case to mount the control directly to a wall or panel board. Mount the control so that the pressure connections on the bellows are above the crankcase liquid level of the equipment being controlled.

**Note:** When mounting the control to a compressor is required, a mounting bracket (Part No. 271-51) is available.

### Pressure Connections



**CAUTION: Equipment damage hazard.**

- Avoid sharp bends or kinks in the capillary or tubing to avoid damage to the capillary.
- Coil and secure excess capillary or tubing. Because harmonic vibration can break the capillary or tubing, some slack must be provided.
- Do not allow the capillary or tubing to rub against metal surfaces where friction can cause damage.
- When using a control with 1/4 in. / 6.4 mm tubing, a pulsation damper must be used. Pulsation can cause excessive wear and damage the control.

1. Purge all tubing and lines before connecting the pressure control.
2. Connect the oil pressure line pump discharge to the pressure connector labeled "OIL."
3. Connect the crankcase pressure line to the pressure connector labeled "LOW."
4. Coil and secure excess capillary or tubing to avoid vibration.

### Wiring



**WARNING: Shock hazard.** Disconnect all power supplies before making wiring connections to avoid electrical shock or damage to the equipment.

- Make all wiring connections using copper conductors only.
- Wire in accordance with National Electric Code and local regulations. For maximum electrical rating of the control, see the label inside the control cover.
- Use the terminal screws furnished (8-32 x 1/4 in. binder head). Substitution of other screws may cause faulty connections.

See Figures 3 through 10 for typical wiring diagrams or refer to the compressor manufacturer's specifications.

When the P28 or P128 control is supplied with a Terminal 3, it may be wired to operate a runlight for indicating when there is sufficient net oil pressure. When the control is supplied with a Terminal A, it can be wired to operate a shutdown alarm or signal for indicating when the compressor has tripped.

For applications using a 208V control circuit, it is suggested that one leg of the 208V circuit and a neutral or ground wire be used as a 120V source to power the time delay relay.

When a P28 or P128 is installed on a 440 or 550 VAC system, use an external step-down transformer to provide either 120 or 240V to the pilot and time delay relay circuits. The transformer must be of sufficient volt ampere capacity to operate the motor starter and the time delay relay. Table 1 presents the power requirements for the P28 or P128 time delay relay. Table 2 presents the electrical ratings.

**Table 1: Electrical Power Required for Time Delay Relay**

Timing in Seconds	Voltage	
	12, 24, or 120V	240V
30, 45, 60, 90, or 120	15 VA	30 VA

**Table 2: Electrical Ratings--Pilot Duty**

Time Delay Relay Circuit	Pilot Circuit	Alarm Circuit*	Crankcase Heater** (Terminal 1)	Runlight** (Terminal 3)
120/240 VAC	750 VA, 120/240 VAC	10W Tungsten, 120/240 VAC	10 Ampere, 120 VAC 5 Ampere, 240 VAC	10W Tungsten
24 VAC/VDC 12 VAC/VDC	125 VA, 24 VAC 57.5 VA, 24 VDC	125 VA, 24 VAC 57.5 VA, 24 VDC	--	10W Tungsten

\* Must be the same voltage as the pilot circuit.

\*\* Must be the same voltage as the time delay relay circuit.

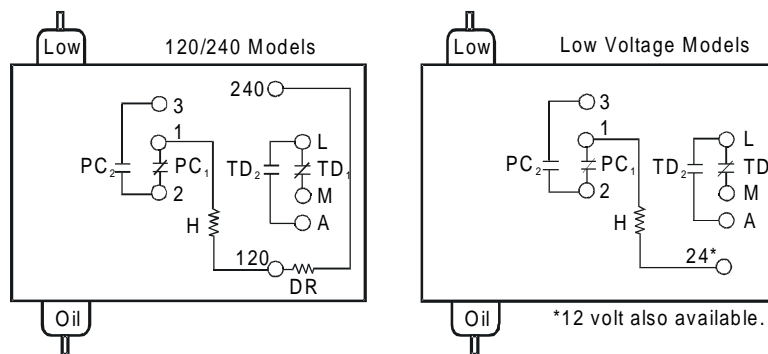

PC<sub>1</sub> - Pressure actuated contacts. Open on increase in pressure difference between oil and low pressure connectors. Makes and breaks time delay heater circuit.

PC<sub>2</sub> - Contacts close simultaneously when PC<sub>1</sub> contacts open (runlight circuit).

TD<sub>1</sub> - Time delay relay. Contacts open after time delay interval if pressure difference between oil and low pressure connectors is not established or maintained.

TD<sub>2</sub> - Contacts close simultaneously when TD<sub>1</sub> contacts open (alarm circuit).

DR - Voltage dropping resistor used in dual voltage models.

H - Heater for time delay relay.

Connect Terminals L and M as a single pole switch.

Connect Terminals 2 and 240 or 120 to energize circuit only when motor starter is closed.

**Figure 3: P28 or P128 Internal Wiring Circuit, Showing Alarm Circuit and Runlight Terminals**

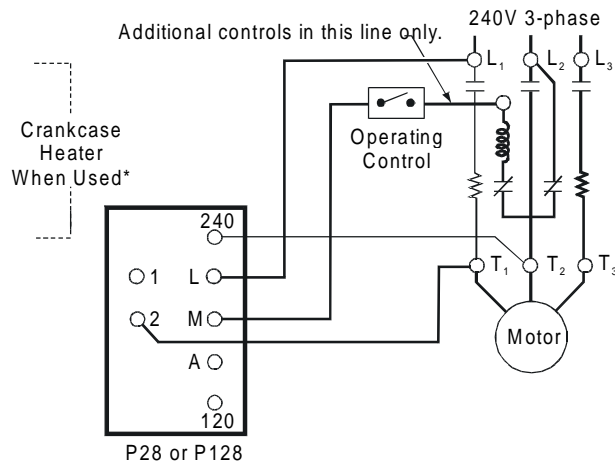

\*Crankcase heater cannot be cycled with this hookup. See Figure 5.

**Figure 4: P28 or P128 Used on a 240V System with 240V Magnetic Starter Coil**

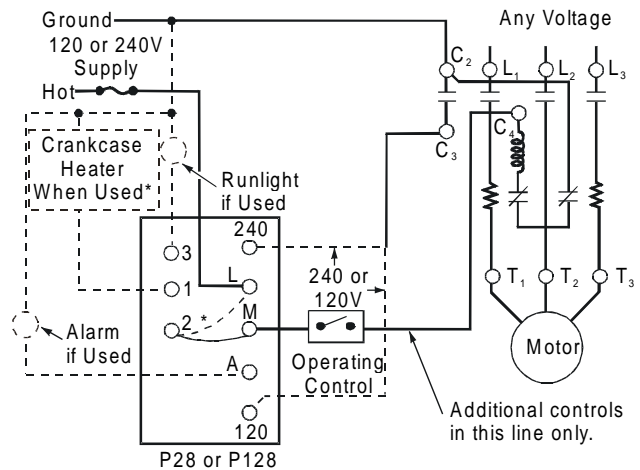

\*When crankcase heater is used, disconnect jumper from 2 to M and reconnect from 2 to L.

**Figure 6: P28 or P128 Where Separate Supply is Provided for Control Circuit (Jumper between 2 and M [or L] must be field installed.)**

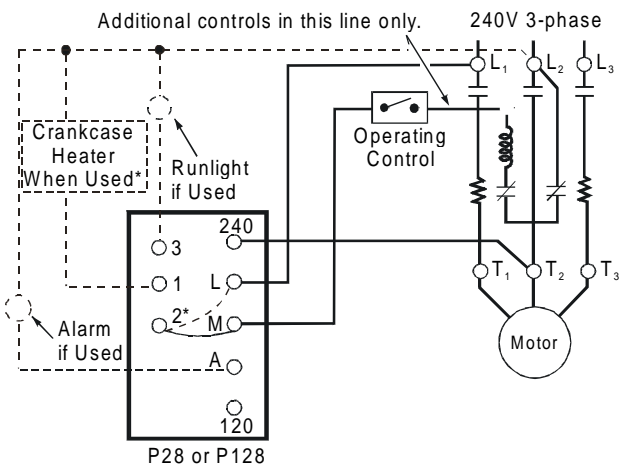

\*When crankcase heater is used, disconnect jumper from 2 to M and reconnect from 2 to L.

**Figure 5: P28 or P128 Wired for 3-wire Control (Jumper between 2 and M [or L] must be field installed.)**

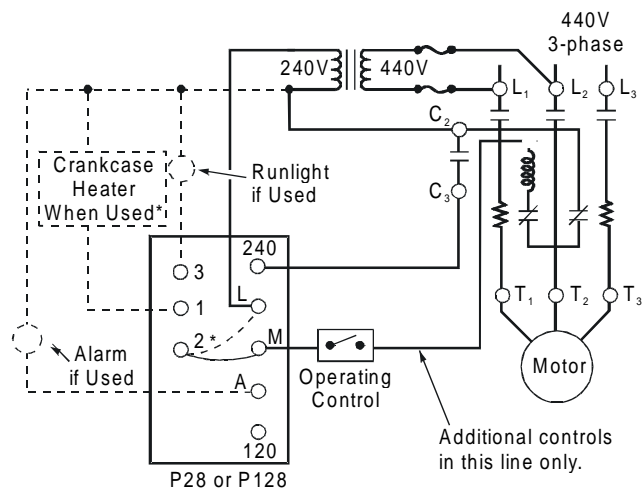

\*When crankcase heater is used, disconnect jumper 2 to M and reconnect 2 to L. Also, make sure that control circuit transformer has sufficient output for additional load.

**Figure 7: P28 or P128 Wired for 440V Supply and 240V Magnetic Start Coil (Also for 550V Using Proper Transformer) (Jumper between 2 and M [or L] must be field installed.)**

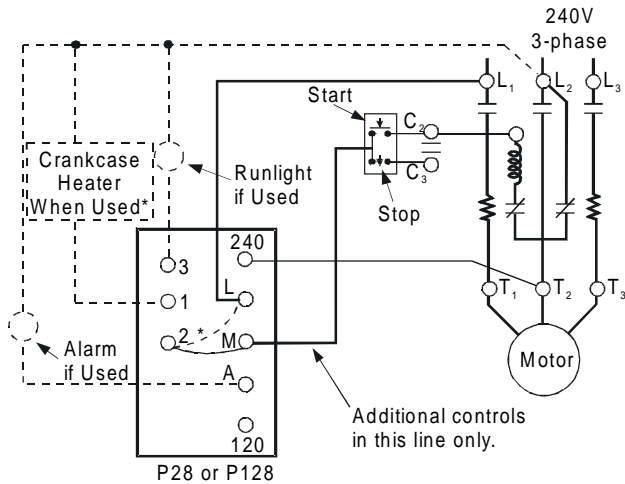

\*When crankcase heater is used, disconnect jumper from 2 to M and reconnect 2 to L.

**Figure 8: P28 or P128 Where Manual “Start-Stop” Pushbutton Station is Used (Jumper between 2 and M [or L] must be field installed.)**

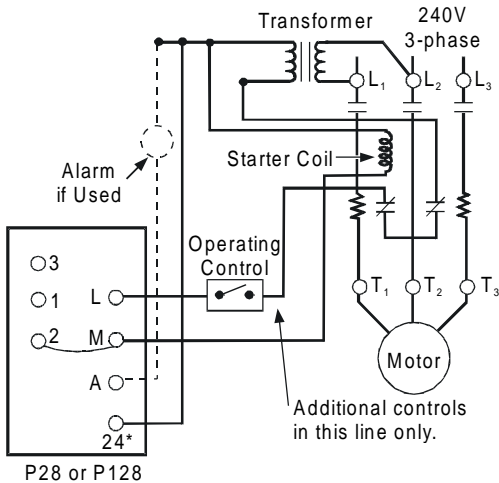

\*12 volt also available.

**Figure 9: P28 or P128 Where 24V Control Circuit Power is from a Step-down Transformer (Jumper between 2 and M must be field installed.)**

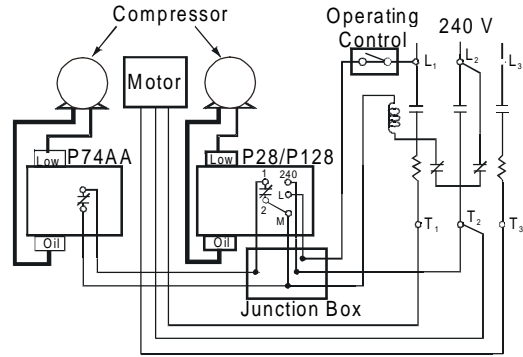

Note: This system would provide shutdown on low lube oil pressure in either of two compressors operated by the common motor.

**Figure 10: P28 or P128 and P74AA Wired for an Oil Pressure Control System Where One Motor Operates Two Compressors**

## Adjustments

The P28 and P128 controls are shipped with a cut-out pressure differential of 9 psi (62 kPa). However, the controls can be adjusted according to the compressor manufacturer’s specifications.

Note: When the controls are shipped as an accessory to the compressor unit, time delay and cut-out pressure are set to manufacturer’s specifications. Replacement controls should duplicate the manufacturer’s specifications.

**CAUTION: Equipment damage hazard.**

To avoid damage to the compressor, obtain the compressor manufacturer’s net oil bearing pressure specifications as soon as possible. If necessary, reset the cut-out pressure difference to the manufacturer’s specifications.

When the manufacturer’s specifications are not known, proceed as follows to set the cut-out pressure differential:

1. With the compressor running, read the oil pressure and the crankcase pressure.
2. Subtract the crankcase pressure reading from the oil pressure pump discharge reading. This is the net oil pressure to the bearings.

- Set the cut-out pointer 6 to 8 psi (41 to 55 kPa) below the established running net oil pressure with the Adjusting Disk using a standard screwdriver.

To increase the cut-out pressure, turn the Adjusting Disk counterclockwise. To decrease, turn clockwise.

To raise the pressure differential, turn the Adjusting Disk (see Figure 2) to the left when viewing the front of the control. Turn the adjusting disk to the right to lower the pressure differential.

## Test for Shutdown

Immediately after installing, and at regular intervals thereafter, the time delay relay should be tested to verify that all circuits are operating correctly.



**WARNING: Shock hazard.** Disconnect power from the control before testing for shutdown to avoid electrical shock or damage to the equipment.

To test for shutdown:

- Remove power from the control and remove the control cover.
- Connect a jumper between Terminals 1 and 2. See Figure 3 for terminal locations.

**Note:** If the control is mounted on a condensing unit where air from auxiliary equipment (blowers or fans) may strike the control, the control cover should be replaced before proceeding to Step 3.

- Apply power to start the compressor. The time delay relay should trip after the time interval and stop the compressor.
- Remove power from the control and remove the jumper between Terminals 1 and 2.
- Replace the cover on the control and apply power.
- Manually reset the time delay relay if required.

## Checkout Procedure

Before leaving the installation, observe at least three complete operating cycles to be sure that all components are functioning correctly.

## Fungus Proofing

Fungus proofing can be supplied at extra cost when specified. Conforms to government specifications MIL-V-173A.

## Repairs and Replacement

Field repairs must not be made, except for replacement of the time delay relay assembly. For a replacement control or time delay relay assembly, contact the nearest Johnson Controls representative or Refrigeration Application Engineering at 414-274-5535.

**Table 3: Replacement Time Delay Relay Assemblies**

Part Number	Voltage	Reset Type	Timing in Seconds	Alarm Circuit
RLY13A-600R	120/240 VAC	Manual	60	No
RLY13A-602R	120/240 VAC	Manual	90	No
RLY13A-603R	120/240 VAC	Manual	90	Yes
RLY13A-608R	120/240 VAC	Automatic	90	No
RLY13A-609R	24 VAC/VDC	Manual	120	No
RLY13A-610R	120/240 VAC	Manual	30	No
RLY13A-616R	120/240 VAC	Manual	120	No
RLY13A-617R	120/240 VAC	Manual	45	No

# Ordering Information

**Table 4: Ordering Information**

Series Part Number	Pressure Connections*	Reset Type	Refrigerant	Time Delay Relay Voltage	Alarm Terminal	Runlight Terminal
P28AA	Style 13, Style 5, or Style 15	Manual	Non-corrosive All-range	120/240 VAC	No	No
P128AA	Style 5	Manual	Non-corrosive All-range	120/240 VAC	No	No
P28AN	Style 15	Manual	Ammonia	120/240 VAC	No	No
P28DA	Style 13	Manual	Non-corrosive All-range	120/240 VAC	Yes	Yes
P28DN	Style 15	Manual	Ammonia	120/240 VAC	Yes	Yes
P28GA	Style 13	Automatic	Non-corrosive All-range	120/240 VAC	No	No
P28NA	Style 13 or Style 5	Manual	Non-corrosive All-range	24 VAC/DC	No	No
P28PA	Style 5	Manual	Non-corrosive All-range	24 VAC/DC	No	No

\* Style 5 connections are 1/4 in. / 6.4 mm SAE male flare connectors (no capillary tubing). Style 13 connections are 3/8 in. / 9.5 mm capillary tubing and 1/4 in. / 6.4 mm flare nut. Style 15 connections are 1/4 in. / 6.4 mm female National Pipe Thread connectors.

## Specifications

<b>Product</b>	P28 and P128 Series Lube Oil Controls with Built-in Time Delay Relay
<b>Power Requirements</b>	See Tables 1 and 2.
<b>Pressure Specifications</b>	Adjustable Cut-out Pressure Difference: 8 to 70 psi (55 to 483 kPa)* Maximum Differential: 70 psi (483 kPa) Maximum Working Pressure: 250 psig (1724 kPa) on the high side Maximum Overpressure: 325 psi (2240 kPa) oil and low side pressure <i>*The time delay relay is de-energized 3 to 5 psi (21 to 34 kPa) above the cut-out scale setting.</i>
<b>Pressure Switch Units</b>	Enclosed Dust-protected Pennswitch
<b>Ambient Operating Conditions</b>	32 to 104°F / 0 to 40°C
<b>Material</b>	Case: 0.062 in. / 1.6 mm Galvanized Steel Cover: 0.028 in. / 0.7 mm Cold Rolled Steel (plated and painted)
<b>Mounting</b>	Flat Surface or with a Universal Mounting Bracket (Part No. 271-51)
<b>Wiring Terminal</b>	Large 8-32 x 1/4 in. Binder Head Screws
<b>Agency Listings</b>	UL Guide No. SDFY; File SA516** CSA Class No. 1222 01; File LR948** <i>**Most models. Contact Johnson Controls for a complete listing.</i>
<b>Dimensions (H x W x D)</b>	5.66 x 5.32 x 2.09 in. / 144 x 135 x 53 mm
<b>Shipping Weight</b>	3.0 lb / 1.36 kg

The performance specifications are nominal and conform to acceptable industry standards. For application at conditions beyond these specifications, consult the local Johnson Controls Refrigeration Application Engineering at (414) 274-5535. Johnson Controls, Inc. shall not be liable for damages resulting from misapplication or misuse of its products.



Controls Group  
507 E. Michigan Street  
P.O. Box 423  
Milwaukee, WI 53201

FAN 125  
Master Catalog  
Printed in U.S.A.