

C-7355 Electromechanical Series 7-Day Time Clocks

The C-7355 Electromechanical Series of 7-Day Time Clocks provides an economical control solution for automatic On/Off switching of equipment. Electromechanical time clocks are available in the following types: C-7355-7 (1 channel with a synchronous drive motor) and C-7355-8 (1 channel with quartz stabilized movement and battery reserve).

The C-7355 Electromechanical Series uses heavy duty single-pole/double-throw (SPDT) contacts (rated 21 amps at 240 VAC resistive) to switch line voltage loads. Up to 12 two-hour On/Off events per day can be programmed.

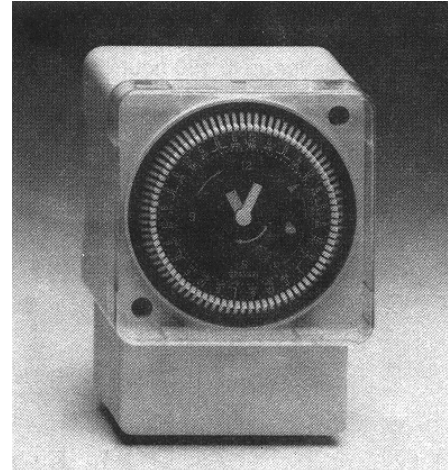

Figure 1: C-7355 Electromechanical Series Time Clock

Features and Benefits	
<input type="checkbox"/> Economical Cost	Makes time-of-day control affordable
<input type="checkbox"/> Front-mount Terminal Block	Reduces wiring and installation time
<input type="checkbox"/> Heavy Duty Switch Rating	Allows larger loads to be switched
<input type="checkbox"/> Manual 3-way Override	Allows for permanent On or Off status
<input type="checkbox"/> Battery Backup	Retains settings upon loss of power (C-7355-8 only)

Introduction

The C-7355 Electromechanical Series 7-Day Time Clocks turn equipment On and Off according to a user-defined, time-of-day schedule, which is set by adjustable On/Off captive trippers.

The C-7355-7 is an electromechanical style time clock with a synchronous drive motor. The C-7355-8 is an electromechanical style time clock with quartz stabilized movement. The C-7355-8 also has a built-in Ni-Cad battery that will maintain clock operation and switching schedules for up to 150 hours in the event of a power failure.

Theory of Operation

The C-7355 Electromechanical Series switches a load On and Off during programmed events. The NO and COM output terminals are open during programmed Off events and are switched closed during programmed On events.

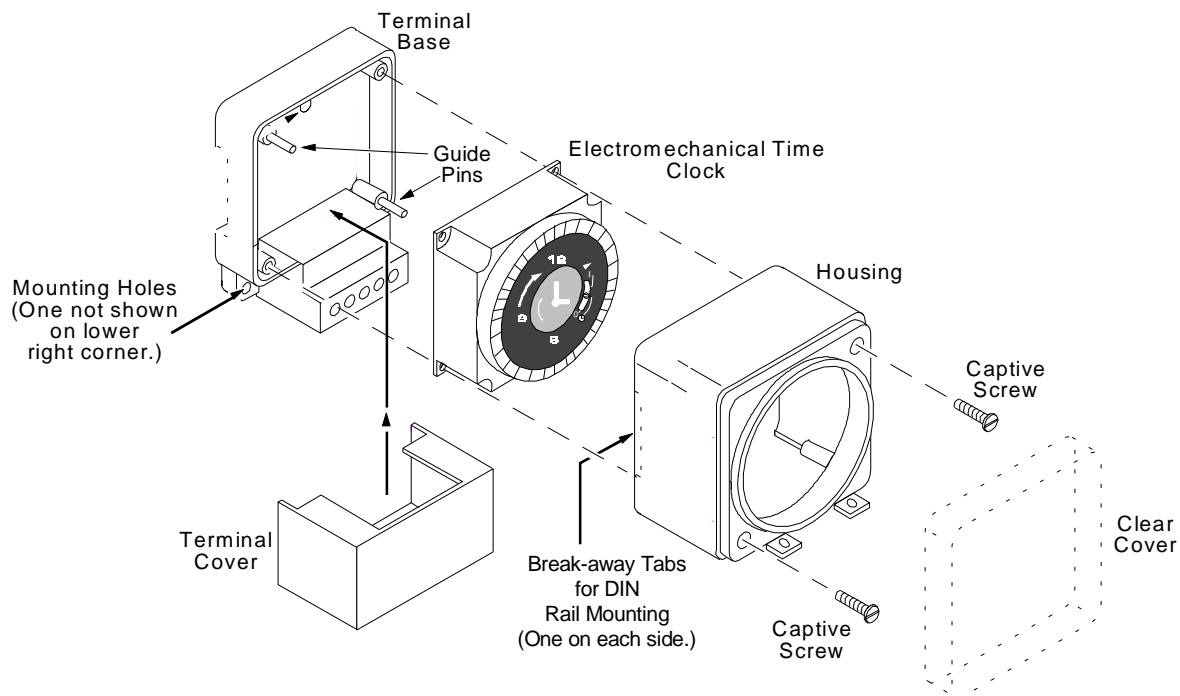

Figure 2: C-7355 Electromechanical Series 7-Day Time Clock

Supplies Needed

- drill
- 3/16 in. (5 mm) drill bit
- screwdriver
- blunt-nose pliers
- marking pencil
- wire stripper

Product Dimensions

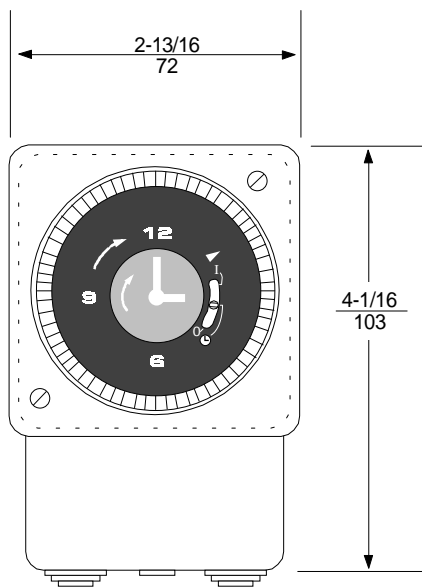

Figure 3: C-7355 Front View (in./mm)

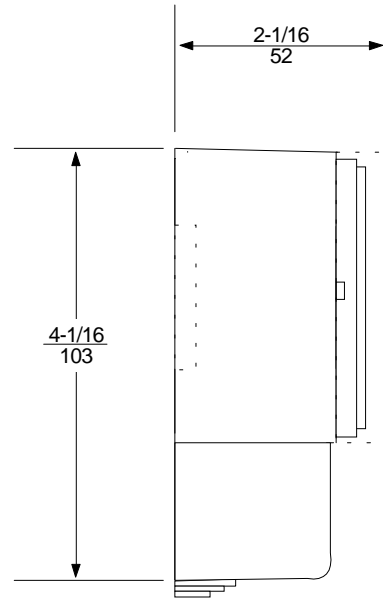

Figure 4: C-7355 Side View (in./mm)

Installation and Wiring

DIN Rail Mounting

Use the following instructions to mount the time clock on a standard 35 mm DIN rail.

1. Remove the clear cover from the front of the time clock.
2. Using a screwdriver, loosen the two captive screws located in the upper right and lower left corners of the housing. See Figure 2.
3. Remove the housing by pulling forward.
4. Using blunt-nose pliers, remove the break-away tabs from the housing. See Figure 5.
5. Remove the terminal cover by pulling forward.
6. Snap the time clock onto the DIN rail.
7. Make wiring connections (refer to *Wiring* section). Remove the appropriate knockouts on the terminal cover for wire entry. See Figure 6.
8. Replace the terminal cover and housing, tighten the captive screws, and replace the clear cover.

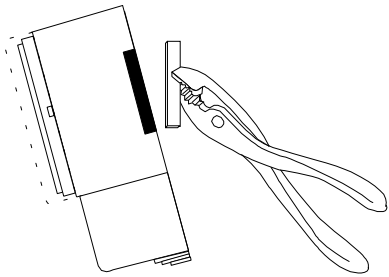

Figure 5: Removing DIN Rail Knockouts

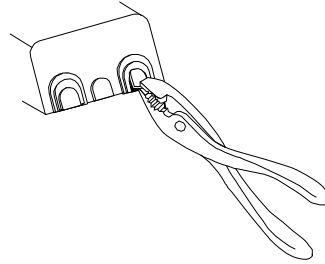

Figure 6: Removing Wire Entry Knockouts

Surface Mounting

Use the following instructions to mount the time clock on a flat surface. The time clock is not position sensitive and can be mounted in any orientation. However, vertical mounting is recommended to aid in programming.

1. Remove the clear cover from the front of the time clock.
2. Using a screwdriver, loosen the two captive screws located in the upper right and lower left corners of the housing.
3. Remove the housing by pulling forward.
4. Remove the terminal cover by pulling forward.
5. Use the mounting template (Figure 10) or place the terminal base against the desired mounting surface and mark the location of the two mounting holes along the bottom of the terminal base. (See Figure 2.)
6. Drill two 3/16 in. (5 mm) holes at the marked locations, tap the provided anchors flush with the wall surface, and fasten the terminal base to the wall with the two #6 screws provided.
7. Make wiring connections (refer to *Wiring* section). Remove the appropriate knockouts on the terminal cover for wire entry. See Figure 6.
8. Replace the terminal cover, and housing; tighten the captive screws; and replace the clear cover.

Enclosure Mounting

If an enclosure is required, see *Table 3: Ordering Information*. Follow the instructions included with the enclosure.

Wiring



WARNING: Shock Hazard. Disconnect all power supplies before wiring connections are made to avoid electrical shock or possible damage to the equipment.

1. Wire the time clock according to national and/or local electrical codes. Terminals will accept 10 to 24 AWG copper wire. See Figures 7 and 8.

2. Insert the wires in the screw-down terminal in accordance with the terminal designations in Table 1.
3. Tighten the screw-down terminals to secure the wires.

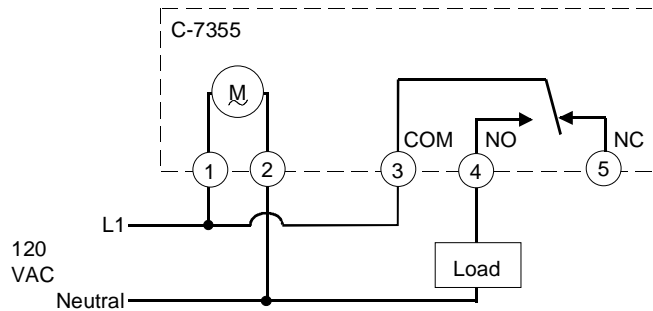

Figure 7: Typical C-7355 Line Voltage Wiring Diagram

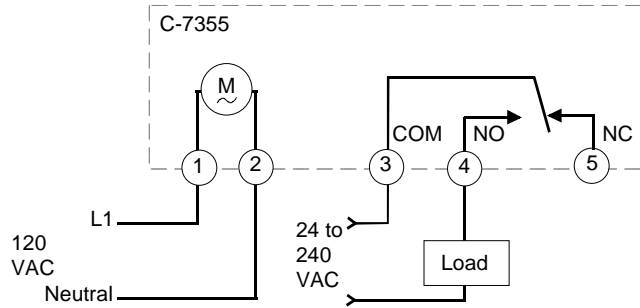

Figure 8: Typical C-7355 Wiring Diagram Switching Voltage Other than 120 VAC

Table 1: C-7355 Terminal Designations

Terminal Number	Description
1	L1 (120 VAC)
2	Neutral
3	COM (output common)
4	NO (switched output)
5	NC (switched output)

Programming

Overview

The C-7355 Electromechanical Series Time Clocks have a clock face with minute and hour hands. The dial face shows the seven days of the week and a.m./p.m. markings for each day.

Setting the Current Time and Day

IMPORTANT: Turn the dial face and minute hand in the clockwise direction only. Turning the wrong way may damage the time clock.

To set the current day and time, turn the outer dial clockwise until the current day of the week is aligned with the triangle marker on the inner dial. Then turn the minute hand clockwise until the current time of day is aligned with the triangle marker on the inner dial. The hour and minute hands will then show the current time of day. See Figure 9.

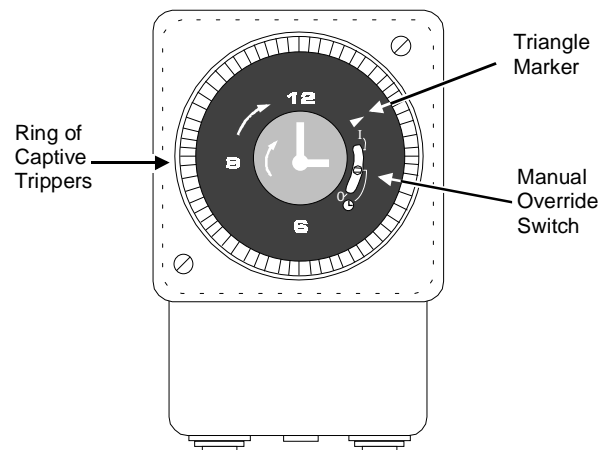

Figure 9: C-7355 Electromechanical Series Dial Face

Setting On/Off Events

The dial face shows the seven days of the week and the a.m./p.m. markings for each day. Each day contains 12 captive trippers. Each tripper represents a 2-hour block of time. Up to 84 On/Off events can be programmed per week. Push the captive trippers to the outer ring position for the entire period of time that the load is to be turned On. Push the captive trippers to the inner ring position for the entire period of time that the load is to be turned Off.

Manual Override

The manual override switch can be positioned to allow automatic, permanent On, or permanent Off control. See Figure 9.

When the manual override switch is in the automatic position “⌚”, the time clock switches the load On and Off according to the programmed events.

When the manual override switch is in the permanent On position “I”, the time clock turns the load On and overrides all programmed events. The clock remains

in the On position until the manual override switch is placed in the automatic or permanent Off position.

When the manual override switch is in the permanent Off position “0”, the time clock turns the load Off and overrides all programmed events. The clock remains in the Off position until the manual override switch is placed in the automatic or permanent On position.

Power Failures

In the event of a power failure, the C-7355-7 does not operate. The time and day of the unit must be reset once power is restored.

The C-7355-8 uses a built-in Ni-Cad battery for backup. In the event of a power failure, the outputs are disabled but the time clock maintains clock operation and programmed events for up to 150 hours.

Repair Information

Field repairs must not be made. For a replacement time clock, contact the nearest Johnson Controls representative.

Troubleshooting

Table 2: Troubleshooting

Symptom	Possible Cause	Corrective Action
Clock does not function...	Supply voltage is incorrect	Use a voltmeter to check the voltage between terminals 1 and 2. Voltage should be between 102 and 132 VAC.
Load does not switch correctly...	Time clock wiring is incorrect	Refer to the <i>Wiring</i> section for correct wiring of the time clock.
	Manual override switch is in the Off (0) position	Place the manual override switch in the automatic position.
	Damaged contacts	Use an ohmmeter to check the resistance difference of the switch terminals. Position the manual override switch to “I”. The resistance between the COM and NO contacts should be less than 1 ohm. The resistance between the COM and NC contacts should be infinity. Place the manual override switch to the “0” position. The resistance between the COM and NO contacts should be infinity. The resistance between the COM and NC contacts should be less than 1 ohm. If the resistance is incorrect, replace the unit.
Clock time is off by more than what is specified...	120 VAC line frequency is not 60 Hz (C-7355-7 only)	Contact the power company to correct the line frequency (C-7355-7 only).
	Quartz unit failure (C-7355-8 only)	Replace the unit (C-7355-8 only).

Ordering Information

Table 3: Ordering Information

Item	Product Code Number
Electromechanical Time Clock, 1 Channel, Synchronous Drive Motor	C-7355-7
Electromechanical Time Clock, 1 Channel, Quartz Stabilized Movement with Battery Backup	C-7355-8
Metal Indoor Enclosure	BOX-7355-1

Mounting Template

The mounting template shown in Figure 10 can be used when surface mounting a C-7355 time clock.

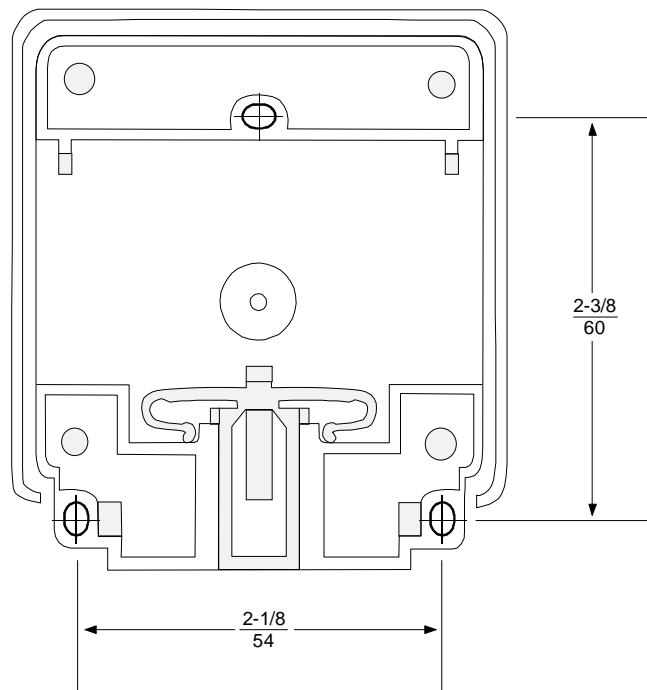

Figure 10: Surface Mounting Template (in./mm)

Specifications

Product	C-7355-7 Electromechanical Time Clock, 1 Channel, Synchronous Drive Motor C-7355-8 Electromechanical Time Clock, 1 Channel, Quartz Stabilized Movement	
Power Requirements	C-7355-7:	120 VAC +10%, -15%, 60 Hz
	C-7355-8:	120 VAC +10%, -15%, 50/60 Hz
Switching Capacity	Maximum:	21 amps resistive @ 240 VAC
	Maximum:	2 hp (12 amps inductive) @ 240 VAC; 1 hp (16 amps inductive) @ 120 VAC
	Minimum:	100 mA @ 20 VAC
Output Type	SPDT	
Power Consumption	1 VA	
Clock Accuracy	C-7355-7:	±24 minutes/year (based on 60 Hz line frequency)
	C-7355-8:	±10 minutes/year
Battery Backup	C-7355-8:	150 hours
Shortest Switching Time	2 hours	
Set Points	84 events per week	
Wire Gauge	10 to 24 AWG	
Mounting	Surface, 35 mm DIN rail, or Enclosure	
Ambient Operating Temperature	C-7355-7:	-4°F to 150°F (-20°C to 66°C)
	C-7355-8:	-4°F to 131°F (-20°C to 55°C)
Ambient Storage Temperature	C-7355-7:	-20°F to 185°F (-29°C to 85°C)
	C-7355-8:	-20°F to 150°F (-29°C to 66°C)
Ambient Humidity	0 to 95% RH, non-condensing; 85°F (20°C) maximum dew point	
UL Recognized	Grasslin File E83486	
Canadian UL Recognized	Grasslin File E83486	
Dimensions (H x W x D)	4-1/16 x 2-13/16 x 2-1/16 in. (103 x 72 x 52 mm)	
Shipping Weight	C-7355-7:	0.37 lb (0.168 kg)
	C-7355-8:	0.39 lb (0.178 kg)

The performance specifications are nominal and conform to acceptable industry standards. For application at conditions beyond these specifications, consult the local Johnson Controls office. Johnson Controls, Inc. shall not be liable for damages resulting from misapplication or misuse of its products.



Controls Group
507 E. Michigan Street
P.O. Box 43
Milwaukee, WI 53201

Printed in U.S.A.