



A421 Series Standard Electronic Temperature Controls with Power Cords Installation Guide

Part No. 24-7664-3027 Rev. D

2019-01-24

Applications

- **Important:** Use this A421 Series Electronic Temperature Control only as an operating control. Where failure or malfunction of the A421 Control could lead to personal injury or property damage to the controlled equipment or other property, additional precautions must be designed into the control system. Incorporate and maintain other devices, such as supervisory or alarm systems or safety or limit controls, intended to warn of or protect against failure or malfunction of the A421 Control.
- **Important:** Utiliser ce A421 Series Electronic Temperature Control uniquement en tant que dispositif de régulation. Lorsqu'une défaillance ou un dysfonctionnement du A421 Control risque de provoquer des blessures ou d'endommager l'équipement contrôlé ou un autre équipement, la conception du système de contrôle doit intégrer des dispositifs de protection supplémentaires. Veiller dans ce cas à intégrer de façon permanente d'autres dispositifs, tels que des systèmes de supervision ou d'alarme, ou des dispositifs de sécurité ou de limitation, ayant une fonction d'avertissement ou de protection en cas de défaillance ou de dysfonctionnement du A421 Control.

The A421 Series Electronic Temperature Controls with Power Cords are single-stage, electronic temperature controls with a single-pole, double-throw (SPDT) output relay and 120 VAC power cords factory wired to the control.

A421 Controls feature a backlit LCD with adjustable brightness and three-button touchpad interface that you can set up to restrict user adjustments. An LED indicates the output relay's on and off status.

A421 Control models have simple on and off temperature settings for heating or cooling, an adjustable anti-short cycle delay, temperature setback, and sensor offset capability. The temperature control range is -40°F to 212°F or -40°C to 100°C.

The A421 Controls are available either in Type 1 (NEMA), IP20 (CE), high-impact plastic enclosures suitable for surface or DIN rail mounting (Figure 1), or in Type 4X (NEMA), IP66 (CE) watertight, corrosion-resistant surface mount enclosures (Figure 2).

A421 Control models with Type 1, IP20 enclosures are available with a single power cord and a combination (piggyback) 120 VAC, grounded plug and outlet; or with dual power cords consisting of a 120 VAC grounded plug on a 6 ft cord and 120 VAC grounded outlet on a 6 ft cord.

A421 Control models with Type 4X, IP66 enclosures are available with a single power cord and a combination (piggyback) 120 VAC, grounded plug and outlet.

See [Ordering information](#) for more model information and accessories.

Dimensions

Figure 1: A421 Control with Type 1 (NEMA), IP20 enclosure dimensions, in. (mm)

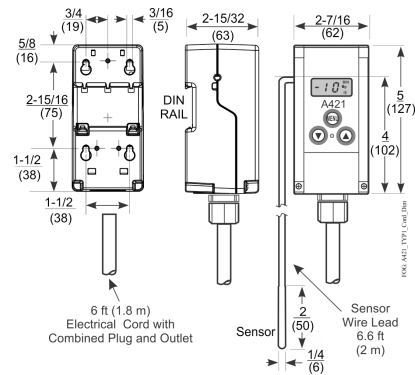
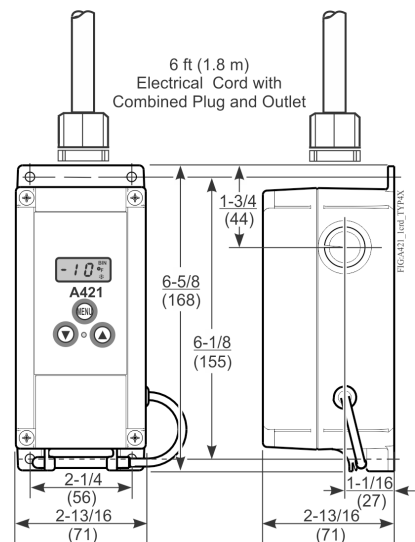

Figure 2: A421 Control with Type 4X (NEMA), IP66 enclosure dimensions, in. (mm)



Parts included

Each A421 Control includes a Johnson Controls® or PENN® A99 Series temperature sensor. See [A99 Series Temperature Sensors, Wiring, and Technical specifications](#) for more information about A99 sensors.

A99 Series Temperature Sensors

The A421 Controls require an A99 sensor, and each A421 Control includes an A99 sensor. Any A99 Series sensor

works with the A421 Series Controls. Do not replace an A99 Series sensor with any other brand, series, or type of temperature sensor. See [Ordering information](#) for available A99 Series sensor models.

You can extend the sensor leads in the field. See Table 1 for wire sizes and lengths. On long sensor cable runs, use shielded cable to reduce electromagnetic interference (EMI). Observe EMI best practices when you route sensor leads.

Do not completely immerse the A99 Series sensors in water or any other liquid. The A99 sensors are moisture tolerant and splash resistant but if you immerse the sensor, liquid can enter the sensor probe where the steel tube meets the wire cable and result in sensor failure, which voids any warranty.

In applications where the sensor may be exposed to a lot of moisture, splashing, or rain, it is best practice to mount the sensor in a vertical position with the cable at the bottom routed downward so that moisture can drain away from the stainless steel probe. Use a suitable bulb well for complete fluid immersion applications. See [Ordering information](#) for information about bulb wells.

The A99 Series sensors are positive temperature coefficient (PTC) sensors. To test an A99 sensor, disconnect the sensor from the control and measure the resistance between the sensor leads in the following situations:

- When the temperature at the sensor is 77°F (25°C), the resistance should be 1,035 ohms.
- When the temperature at the sensor is 32°F (0°C), the resistance should be 855 ohms.

See [Troubleshooting](#) for more information.

When you connect an A99 sensor to a standard A421 Control, the control restricts the range of usable values from -40°F to 212°F or -40°C to 100°C.

See [Wiring](#), [Technical specifications](#), and refer to the *A99B Series Temperature Sensors Product/Technical Bulletin (LIT-125186)* for more information about A99 Series sensors.

Mounting

Observe the following guidelines when you locate and mount an A421 Control:

- Make sure that the mounting surface can support the control, DIN rail, mounting hardware, and any user-supplied panel or enclosure.
- Mount the control in a vertical, upright orientation wherever possible. It is best practice to use DIN rail mounting for type 1 controls.
- In direct-mount applications, mount the control on a flat and even surface.

Mount the control in a location free of corrosive vapors and observe the ambient operating conditions listed in [Technical specifications](#) for the A421 Control and the A99 sensor.

- Allow sufficient space to connect and route wires, view the LCD, and use the touchpad.

- Do not mount the control on surfaces that are prone to vibration or in a location where high-voltage relays, motor starters, other sources of electromagnetic emissions, or strong radio frequency may cause interference.
- Do not install the control in an airtight enclosure.
- Do not install heat generating devices with the control in an enclosure that may cause the ambient temperature to exceed 150°F (66°C).

Mounting a Type 1/IP20 control on DIN rail

1. Provide a section of 35 mm DIN rail that is longer than the control width. Mount the DIN rail in a suitable location and use appropriate mounting hardware.
2. Clip the control module on the rail, position the module's upper DIN rail clips on the top rail, and gently snap the lower clips on to the bottom of the rail.

Direct-mounting a Type 1/IP20 control to a wall or other flat surface using the four keyhole slots

1. Disconnect the power and remove the enclosure cover. Place the control horizontally against the wall surface in a suitable location, and mark the keyhole slot locations on the mounting surface.
 2. Install appropriate screws or fasteners and leave the screw heads approximately one or two turns away from flush to the mounting surface.
 3. Position the control mounting slots over the screw heads, and then tighten the mounting screws to secure the control to the surface.
- ⓘ **Note:** When you mount the control on an uneven surface, use shims to mount the control evenly.

Additional guidelines for mounting Type 4X/IP66 controls

You can mount the Type 4X models to flat vertical surfaces using the four holes at the enclosure corners. Place the control against a flat wall surface in a suitable location, and mark the mounting screw hole locations on the mounting surface. Use appropriate screws and shims to mount the control evenly on the surface.

On Type 4X models, select the knockout for removal. Place a screwdriver blade on the knockout near the edge. Apply a sharp blow to the screwdriver handle to loosen the knockout. Be careful not to damage the control's interior components.

The A421 Control's temperature setback (BI) function requires an additional low-voltage, two-wire cable for operation. On Type 4X/IP66 enclosures, you must install a suitable watertight fitting in an available knockout to pass the two-wire cable through the enclosure wall.

You can rotate the control enclosure base on the Type 4X/IP66 models 180° relative to the control enclosure cover

and LCD, to bring the electrical connection to either the top or bottom of the mounted control.

- ⓘ **Note:** Do not twist the wiring harness between the enclosure base and cover more than 180°.

Wiring

WARNING

Risk of Electric Shock

Disconnect or isolate all power supplies before making electrical connections. More than one disconnection or isolation may be required to completely de-energize equipment. Contact with components carrying hazardous voltage can cause electric shock and may result in severe personal injury or death.

AVERTISSEMENT

Risque de décharge électrique

Débrancher ou isoler toute alimentation avant de réaliser un raccordement électrique. Plusieurs isolations et débranchements sont peut-être nécessaires pour couper entièrement l'alimentation de l'équipement. Tout contact avec des composants porteurs de tensions dangereuses risque d'entraîner une décharge électrique et de provoquer des blessures graves, voire mortelles.

- **Important:** Do not exceed the A421 Control's electrical ratings. Exceeding control electrical ratings can result in permanent damage to the control and void any warranty.
- **Important:** Make all wiring connections in accordance with the National Electrical Code and local regulations. Use proper Electrostatic Discharge (ESD) precautions during installation and servicing to avoid damaging the electronic circuits of the A421 Controls.
- **Important:** When you connect an A99 sensor with a shielded cable to an A421 Control, connect the cable shield drain lead to the common (COM) terminal on the sensor and binary input terminal block (TB3). Do not connect the shield at any other point along the cable, and isolate and insulate the shield along the entire length of the sensor cable. If you connect a cable shield at more than one point, transient currents can flow through the sensor cable shield and cause erratic control operation.

The A421 Electronic Temperature Controls with Integral Power Cords are prewired for 120 VAC plug-in applications only. Observe the electrical ratings listed in [Technical specifications](#).

Observe the following guidelines, procedures, and illustrations when you wire an A421 Series Control and A99 Series sensor.

- Select the appropriate A99 sensors for the ambient operating range that the A421 Control monitors and controls, as shown in Table 6. See [Technical specifications](#).
- Keep the sensor leads as short as possible in your application. The additional resistance in long sensor cables creates an offset between the actual temperature and the displayed temperature. See Table 1 when you extend sensor leads.
- A99 sensors are not polarity specific. You can connect either lead to the SEN or COM terminals.
- It is best practice to use 22 AWG, stranded, twisted-pair cable with a shield to extend sensor cable runs.

Table 1: Maximum sensor cable lengths and wire sizes

Wire gauge	Maximum sensor cable length ¹
16 AWG	500 ft (150 m)
18 AWG	300 ft (100 m)
20 AWG	200 ft (60 m)
22 AWG	125 ft (40 m)

¹ At the listed maximum cable lengths, there is less than 1F° (0.6C°) error between the temperature sensed at the A99 sensor and the temperature displayed on the LCD.

Table 2: A421 Control Sensor and Binary Input wiring terminals and wire size information

Terminal block	Label	Description, function, and requirements	Wire sizes
TB3	BIN	Detects a switch closure between the BIN and COM terminals and implements the selected temperature setback (tSb) value.	22 AWG (0.34 mm ²) stranded, shielded cable
	COM	Connects low-voltage common from the sensor and binary input.	
	SEN	Connects low-voltage input signal wire from control sensors.	

Setup and adjustments

The front panel of the A421 Series Electronic Temperature Control has an LCD and a three-button UI as shown in the following figure.

Figure 3: A421 Control front panel with LCD and three-button UI

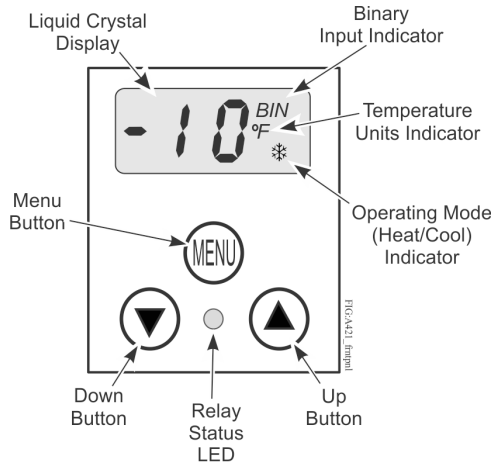

LCD

The A421 Series Control has a backlit LCD screen (Figure 3). You can adjust the LCD brightness. During normal operation, the LCD displays the Main screen, which provides the following information:

- Temperature sensed at the A99 sensor
- Selected temperature units (°F or °C)
- Mode of operation (Flame = Heating mode, Snowflake = Cooling mode)
- Binary Input status (BIN) when a user-supplied binary input (switch) is connected and closed to use the temperature setback feature.

During setup and adjustment, the LCD displays the parameter code screens and the parameter value screens. See the [A421 Control parameter setup menus](#) for more information.

Three-button touchpad

The touchpad has three buttons for set up and adjustment of the A421 Control (Figure 3). See [Navigating the Basic and Advanced menus](#) for more information about the three-button touchpad.

Relay status LED

The green LED on the front panel illuminates when the SPDT output relay is energized. See Figure 3.

- **LED On** = Output Relay energized and the LC contact is closed to the LNO contact
- **LED Off** = Output Relay de-energized and the LC contact is open to the LNO contact

Table 3: Standard parameter setup codes, descriptions, range of values, and default values

Parameter code	Parameter description (menu)	Range of usable values	Factory default value ¹
Un	Temperature Units (Advanced only)	°F or °C	°F

Table 3: Standard parameter setup codes, descriptions, range of values, and default values

Parameter code	Parameter description (menu)	Range of usable values	Factory default value ¹
OFF	Relay Off Temperature (Basic, Advanced, and Restricted)	-40°F to 212°F (-40°C to 100°C)	25°F
On	Relay On Temperature (Basic and Advanced)	-40°F to 212°F (-40°C to 100°C)	30°F
ASd	Anti-Short Cycle Delay (Basic and Advanced)	0 minutes to 12 minutes	1 minute
tSb	Temperature Setback (Advanced only)	-50°F to 50°F (-30°C to 30°C)	0°F
So	Sensor Offset Adjustment (Advanced only)	-5°F to 5°F (-3°C to 3°C)	0°F
HtS	High Temperature Stop (Advanced only)	-40°F to 212°F (-40°C to 100°C)	212°F
LtS	Low Temperature Stop (Advanced only)	-40°F to 212°F (-40°C to 100°C)	-40°F
SF	Sensor Failure Action (Basic and Advanced)	0 = output relay de-energized 1 = output relay energized	1 output relay energized
bLL	LCD Backlight Brightness Level Adjustment (Advanced only)	0 to 10; 0 = backlight off, 10 = brightest backlight setting	10 (brightest backlight)

¹ The default values for general application A421 models are shown. OEM A421 models may have different default values.

Parameter codes and modes of operation

Relay Off temperature (OFF)

Select the temperature at which the output relay de-energizes, the LC to LNO relay contacts open (cutout), and the green LED goes off. The range of usable temperature values is -40°F to 212°F or -40°C to 100°C in 1° increments.

Relay On temperature (On)

Select the temperature at which the output relay energizes, the LC to LNO relay contacts close (cut in), and the green LED lights. The range of usable temperature values is -40°F to 212°F or -40°C to 100°C in 1° increments.

Heating or Cooling mode of operation

When you select your required On and OFF values, the control automatically determines the mode of operation and displays the proper mode icon on the Main screen.

- ⓘ **Note:** The A421 Series Controls do not have jumpers for setting up the heating or cooling mode.

The heating or cooling mode is determined by the On and OFF value relationship as follows:

- **OFF > On** = Heating mode = Flame icon
- **OFF < On** = Cooling mode = Snowflake icon
- **Important:** During normal operation, adjusting just the On value or just the OFF value on the A421 Control changes the differential between On and OFF, and can potentially change the mode of operation from heating to cooling or cooling to heating. To maintain a constant differential between on and off, you must adjust both the on and off values by an equal number of degrees, or set up the control in the Restricted adjustment Mode. See [Restricting user adjustment](#).

Anti-Short Cycle Delay (ASd)

Select the minimum time that the output relay remains off (de-energized) before the next on-cycle can start. The ASd interval overrides any load demand (On) and does not allow the output relay to go on until the selected ASd interval has elapsed. See the following figure.

Figure 4: Anti-short cycle delay

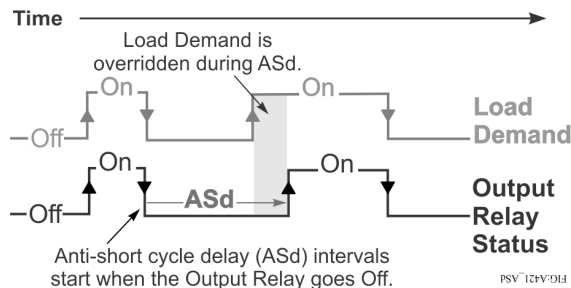

Anti-short cycle delay is typically used for refrigeration applications so that the system pressure can equalize before restarting the compressor.

- ⓘ **Note:** When the ASd value is greater than 0, the delay interval initiates every time that the A421 Control powers on and every time that an off-cycle begins. When the ASd interval is activated, the temperature sensed at the A99 sensor and the parameter code ASd flash alternately on the LCD. You can set the ASd interval from 0 minutes to 12 minutes, in 1 minute increments.

Sensor Failure mode (SF)

Select whether the control's output relay operates as energized or de-energized in the event of a sensor or sensor wiring failure. When the control detects a sensor circuit failure, the output relay operates in the selected sensor failure mode. The LCD flashes SF and OP if the sensor circuit is open or SF and SH if the sensor circuit is shorted.

Temperature Units (Un)

Select the preferred temperature scale for your application. Select either the Fahrenheit (°F) or Celsius (°C) temperature scale.

- ⓘ **Note:** After you change the temperature units value (Un), confirm that the temperature values for the other parameter codes are still correct for your application.

Low Temperature Stop (Lts)

Select the lowest temperature value that the On/OFF control band can be adjusted to when control adjustment is restricted.

High Temperature Stop (HtS)

Select the highest temperature value that the On/OFF control band can be adjusted to when control adjustment is restricted.

Restricted Adjustment mode

The HtS and LtS values define the restricted adjustment temperature range and are enforced only when the A421 Control is set to the restricted adjustment mode (Figure 7). See [Restricting user adjustment](#).

- ⓘ **Note:** It is best practice to leave the HtS and LtS at their default values, unless you intend to use the restricted adjustment mode.
- ⓘ **Note:** If you use the Temperature Setback feature in the Restricted Adjustment mode, the effective On and OFF setback values (On + tBs and OFF + tBs) can be greater than the selected HtS value or less than the selected LtS value.

Temperature Setback (tSb)

Select a temperature value for setting back the On and OFF temperature values. When a user-supplied switch between the BIN and COM terminals closes, note the following changes:

- The Main screen displays BIN in the upper-right corner of the LCD.
 - The temperature setback feature is enabled and the control uses the effective On and OFF setback values (On + tSb and OFF + tSb) to control the relay.
- ⓘ **Note:** The control displays only the original On and OFF values in both the normal and setback modes. The effective setback On and OFF values (On + tSb and OFF + tSb) never display on the control LCD.

The temperature setback adjustment range is from -50°F to 50°F or -30°C to 30°C. Typically, heating applications require a negative temperature setback (tSb) value, and cooling applications require a positive value.

Sensor Offset Adjustment (So)

Sensor offset allows you to compensate for any difference between the displayed temperature value and the temperature sensed at the A99 sensor. Select a temperature value to offset the temperature displayed on the LCD from the temperature sensed at the sensor. The sensor offset adjustment range is from -5°F to 5°F (-3°C to 3°C) in 1° increments.

Backlight Brightness Level (bLL)

The backlight brightness level feature allows you to adjust the LCD backlight intensity. At level 0 the backlight is off. Level 10 is the brightest backlight setting and the system default. The selected backlight brightness level is applied to the LCD during normal operation. When you enter the programming menus to set up the control or press any key, the LCD automatically goes to the brightest level. If you do not press a key for 30 seconds, the main screen displays and the backlight setting reverts to the selected brightness level.

A421 Control parameter setup menus

The A421 Temperature Controls have a Basic and an Advanced setup menu. You can use these menus to scroll through the parameter setup codes, view and edit parameter values, and set up your control for your application requirement. The control also has a Restricted adjustment menu. See [Restricting user adjustment](#) for more information.

- ① **Note:** The A421 Control retains a copy of the saved parameter values in memory. When you change and save a new value, the new value immediately overwrites the previous value and saves to memory. In the event of a power failure, brown out, or when you disconnect power from the control, all of the current parameter values in memory are retained. Reconnecting power to the control restores all of the saved values.

Navigating the Basic and Advanced menus

The A421 Control buttons and display operate the same way in Basic and Advanced menus. The parameter code flashes on and off in any parameter code screen.

1. To navigate through all of the parameter code screens, press **Down** or **Up**.
2. To exit either menu and return to the Main screen, press **Down** and **Up** simultaneously.
3. While in any parameter value screen, the parameter value flashes on and off.

4. To scroll through all of the available parameter values for the associated parameter code, press **Down** or **Up**.
5. With the preferred parameter value displayed, press **MENU** to save the value and go to the next parameter code screen.

- ① **Note:** If you do not press **MENU** to save a new value, the control reverts to the last saved value. After 30 seconds of inactivity, while in any screen, the control reverts to the Main screen.

Basic menu

Use the Basic menu to quickly edit the On and OFF temperature values, as well as the Sensor Failure Mode (SF) and the Anti-Short Cycle Delay (ASd) value.

See [Parameter codes and modes of operation](#) and Table 3 for more information about parameter codes, usable parameter values, and default values.

Figure 5: Navigating the Basic menu

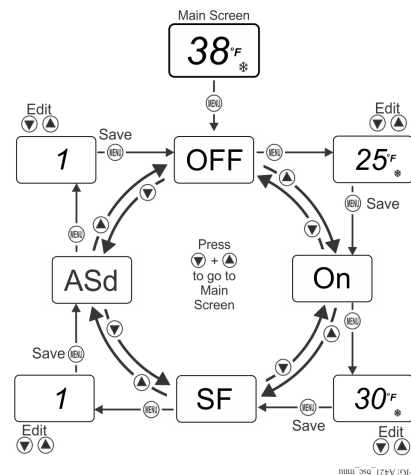

Viewing and changing values in the Basic menu

In this task you access the Basic menu and view and change the Basic parameter values.

1. On the Main screen, press **MENU**. The LCD displays **OFF**, which is the first parameter code screen displayed in the Basic menu.
2. To scroll through all of the basic parameter codes and display the preferred code, press **Down** or **Up**.
3. With the preferred parameter code displayed, press **MENU** to display the current parameter value for the code.
4. With the current parameter value displayed, press **Down** or **Up** to scroll through all of the parameter's usable values and display the preferred value.
5. With the preferred parameter value displayed, press **MENU** to save the displayed value and go to the next parameter code.

- To exit the Basic menu and go to the Advanced menu, simultaneously press and hold **Down** and **Up** for 5 seconds.

Advanced menu

You can use the Advanced menu to change the parameter values in the Basic menu and the parameter values for the following advanced parameter codes:

- Temperature Units (**Un**)
- Temperature Setback (**tSb**)
- Sensor Offset (**So**)
- High Temperature Setpoint Stop (**HtS**)
- Low Temperature Setpoint Stop (**LtS**)
- Backlight Level (**bLL**)

See [Parameter codes and modes of operation](#) and Table 3 for more information about parameter codes, usable parameter values, and default values.

Figure 6: Navigating the Advanced menu

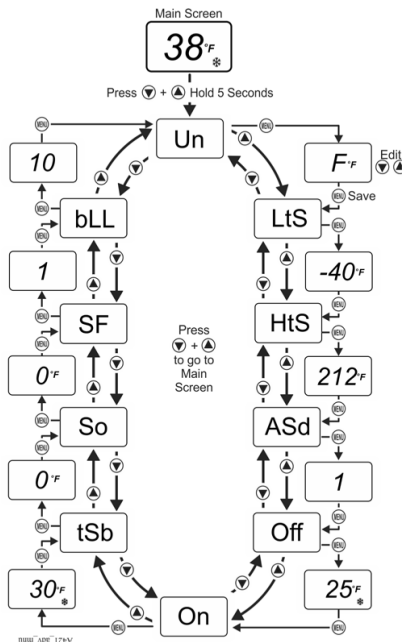

Viewing and changing values in the Advanced menu

In this task you access the Advanced menu and view and change the parameter values.

- On the Main screen, press and hold **Down** and **Up** simultaneously for 5 seconds. **Un** displays on the LCD, which is the first parameter code screen displayed in the Advanced menu.
- To scroll through all of the advanced parameter codes and display the preferred code, press **Down** or **Up**.
- With the preferred parameter code displayed, press **MENU** to display the current parameter value for the code.

- With the current parameter value displayed, press **Down** or **Up** to scroll through all of the parameter code's usable values and display the preferred value.
- With the preferred parameter value displayed, press **MENU** to save the displayed value and go to the next parameter code.

Restricting user adjustment

You can restrict user adjustment of the A421 Control to the OFF value control band only and limit the range of this value (Figure 7).

To set the A421 Control to the restricted adjustment mode, position the jumper located on the circuit board next to the TB3 terminal block. See [Setting the control to Restricted Adjustment mode](#).

- ⓘ **Note:** Setting the A421 Control up in the Restricted mode prevents casual users from over-adjusting the control in your application, or from inadvertently changing the mode of operation from cooling to heating or heating to cooling by over-adjusting the On value or OFF value.

When the A421 Control is set up in the restricted adjustment mode, the controller enforces the following behavior:

- The selected HtS and LtS values define the restricted temperature adjustment range.
- The On and OFF values define the control band differential, and the control band between On and OFF remains fixed and not adjustable.
- Only the OFF value can be adjusted, the control band remains fixed, and the On value automatically shifts equal to the OFF value adjustment.
- The OFF value can only be adjusted to values that maintain the entire control band within the restricted temperature adjustment range defined by HtS and LtS. See Figure 7.
- The basic and advanced menus are not available. Only the Restricted Adjustment mode menu is available and only the OFF value can be adjusted. See Figure 9.

Figure 7: Adjustment behavior in Restricted Adjustment mode

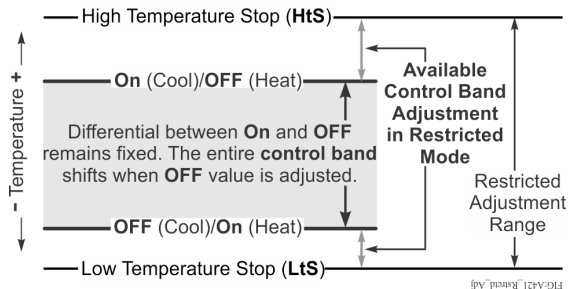

Setting the control to Restricted Adjustment mode

In this task you set up the restricted adjustment feature.

- To make sure that the A421 is not in restricted mode, position the jumper on both pins. See Figure 8.

2. Select the OFF and On values that define the application's required control band (Figure 7).
3. Change the HtS and LtS temperature values to define the restricted adjustment range (Figure 7).
4. Disconnect power to the control, remove the control cover, and reposition the jumper to one pin (Figure 8). Reconnect power.

Figure 8: Repositioning the jumper to restrict control adjustment

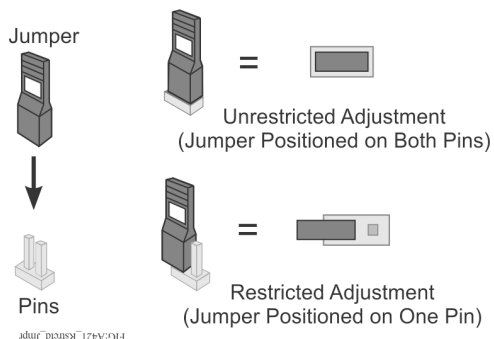

Control adjustment is now restricted to changing only the OFF value, which shifts the On and OFF control band within the restricted adjustment range defined by HtS and LtS (Figure 7).

- ⓘ **Note:** To completely restrict (and lockout) all user adjustment on the control, set the HtS value equal to the On or OFF value and the LtS value equal to the OFF or On value. Then the (On to OFF) control band is equal to the restricted adjustment range, LtS to HtS, and the OFF value cannot be adjusted in the restricted mode.

Adjusting the control in Restricted mode

In this task you adjust the OFF value and shift the On and OFF control band within the restricted adjustment range, when the control is in the restricted adjustment mode.

1. On the Main screen, press **MENU** to go to the Restricted Adjustment mode menu and display the OFF parameter code screen (Figure 9).
2. To go to the OFF value screen press **MENU**.
3. On the OFF value screen, press **Down** or **Up** to change the OFF value within the restricted adjustment range.
4. To save the selected OFF value and return to the OFF code screen, press **MENU**.
5. To return to the Main screen, press **Down** and **Up** simultaneously.

Figure 9: Adjusting temperature in the Restricted Menu

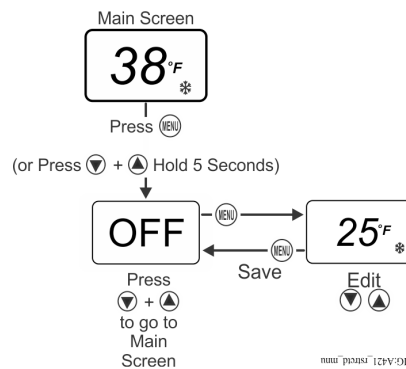

Troubleshooting

A421 Series Controls display fault codes on the LCD as described in the following table.

Table 4: Fault codes

Fault code	Definition	System status	Solution
SF flashing alternately with OP	Open temperature sensor or sensor wiring	Output functions according to the selected SF mode	See Troubleshooting procedure . Cycle power to reset the control.
SF flashing alternately with SH	Shorted temperature sensor or sensor wiring	Output functions according to the selected SF mode	See Troubleshooting procedure . Cycle power to reset the control.
EE	Program failure	Output is off	To reset the control, press MENU . If problems persist, replace the control.

Troubleshooting procedure

1. Check for proper voltage to the A421 Control.
 - a. To remove the cover, loosen the two captive cover screws.
 - b. Use an AC voltmeter to check the voltage between the COM and 120 V.
 - ⓘ **Note:** The voltage must be between 102 VAC and 132 VAC for 120 VAC applications.
 - c. If the voltage reading is not within the required range, check the power source and input power wires for problems.
2. Check for proper sensor operation.
 - a. Disconnect all power sources to the control.
 - b. Use an accurate thermometer to take a temperature reading at the sensor location.
 - c. Disconnect the sensor from the control.
 - d. Use an ohmmeter to measure the resistance across the two sensor leads while the sensor is at

- the temperature taken in Step 2b.
- e. See Figure 10 to verify that the measured temperature and resistance conform to established temperature and resistance values.
- f. If the measured values conform to the values in Figure 10, proceed to Step 3.
- g. If the sensor's measured resistance value is substantially different from the expected value for that temperature, check the sensor wiring. If sensor wiring is correct, replace the sensor.

Figure 10: Temperature versus sensor resistance

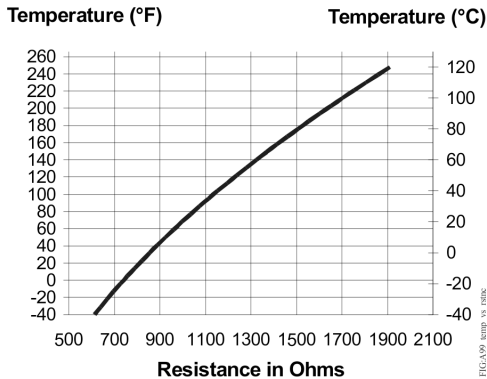

3. Check the A421 for proper operation.
 - ① **Note:** Perform troubleshooting Steps 1 and 2 before you perform this step.
 - a. Disconnect the load from the output relay terminals.
 - b. Make sure that you install the Parameter Adjustments jumper so that you have unrestricted access to adjust parameters.
 - c. Reconnect the sensor leads and supply power to the control.
 - d. Replace the cover.
 - e. Check the control settings for proper values.
 - f. Press **MENU** until **On** appears. Press **MENU** again to display the On value.
 - g. Press **Down** or **Up** to change the On temperature above and below the sensor temperature until the relay energizes and de-energizes.
 - ① **Note:** If the anti-short cycle delay is set to a value other than 0 minutes, when the control is powered On, on the relay does not energize until the time delay elapses.
 - h. If the output relay does not perform as expected, replace the A421 Control.
 - i. If you verify proper operation of the A421 Control, reconnect the load and consult the equipment manufacturer's instructions troubleshoot the controlled equipment.

Repair information

Do not attempt to repair or recalibrate the A421 Temperature Control. In case of a defective or improperly functioning control, contact your nearest

authorized Johnson Controls/PENN distributor or sales representative.

When you contact your Johnson Controls/PENN distributor, have the model number of the control available. You can find this number on the label inside the cover of the control.

Ordering information

See Table 5 to order a standard A421 Series Electronic Temperature Control. See Table 6 and Table 7 for information about sensors, mounting hardware, and other accessories you use to install A421 Controls. Contact your nearest Johnson Controls or PENN distributor or sales representative to order these products.

Table 5: A421 Series Standard Electronic Temperature Controls with power cords selection chart

Product code	Description
A421ABG-02C	120 VAC Type 1 Electronic Temperature Control with Dual Power Cords: Type 1 (NEMA), IP20 enclosure for DIN rail and surface-mount applications, with 6 ft (1.8 m) cord with 120 VAC grounded male plug and 1 ft (0.3 m) cord with 120 VAC grounded female outlet. Rated for 120 VAC. Includes an A99BB-200C temperature sensor with 6.6 ft (2.0 m) cable.
A421ABJ-02C	120 VAC Type 1 Electronic Temperature Control with Piggyback Power Cord: Type 1 (NEMA), IP20 enclosure for DIN rail and surface-mount applications, with 6 ft (1.8 m) single power cord with 120 VAC combination male/female grounded piggyback plug. Rated for 120 VAC. Includes an A99BB-200C temperature sensor with 6.6 ft (2.0 m) cable.
A421AEJ-01C	120 VAC Type 4X Electronic Temperature Control with Piggyback Power Cord: Type 4X (NEMA), IP66 watertight enclosure for surface-mount applications, with 6 ft (1.8 m) single power cord with 120 VAC combination male/female grounded piggyback plug. Rated for 120 VAC. Includes an A99BB-25C temperature sensor with 9 7/8 in. (0.25 m) cable.
A421AEJ-02C	120 VAC Type 4X Electronic Temperature Control with Piggyback Power Cord: Type 4X (NEMA), IP66 watertight enclosure for surface-mount applications, with 6 ft (1.8 m) single power cord with 120 VAC combination male/female grounded piggyback plug. Rated for 120 VAC. Includes an A99BB-200C temperature sensor with 6.6 ft (2.0 m) cable.

Table 6: A99 Temperature Sensors selection chart

Product code ¹	Description
A99BA-200C	Positive temperature coefficient (PTC) Temperature Sensor: Standard probe 2 in. (5.1 cm) with 6.6 ft (2.0 m) shielded polyvinyl chloride (PVC) cable; ambient operating temperature range: -40°F to 212°F (-40°C to 100°C)

Table 6: A99 Temperature Sensors selection chart

Product code ¹	Description
A99BB-25C	PTC Temperature Sensor: Standard probe 2 in. (5.1 cm) with 9 7/8 in. (0.25 m) PVC cable; ambient operating temperature range: -40°F to 212°F (-40°C to 100°C)
A99BB-200C	PTC Temperature Sensor: Standard probe 2 in. (5.1 cm) with 6.6 ft (2.0 m) PVC cable; ambient operating temperature range: -40°F to 212°F (-40°C to 100°C)
A99BB-300C	PTC Temperature Sensor: Standard probe 2 in. (5.1 cm) with 9.8 ft (3.0 m) PVC cable; ambient operating temperature range: -40°F to 212°F (-40°C to 100°C)
A99BB-400C	PTC Temperature Sensor: Standard probe 2 in. (5.1 cm) with 13.1 ft (4.0 m) PVC cable; ambient operating temperature range: -40°F to 212°F (-40°C to 100°C)
A99BB-600C	PTC Temperature Sensor: Standard probe 2 in. (5.1 cm) with 19.7 ft (6.0 m) PVC cable; ambient operating temperature range: -40°F to 212°F (-40°C to 100°C)
A99BC-25C ¹	PTC Temperature Sensor: Standard probe 2 in. (5.1 cm) with 9 7/8 in. (0.25 m) high-temperature silicon cable; ambient operating temperature range: -40°F to 248°F (-40°C to 120°C)
A99BC-100C ¹	PTC Temperature Sensor: Standard probe 2 in. (5.1 cm) with 3.3 ft (1.0 m) high-temperature silicon cable; ambient operating temperature range: -40°F to 248°F (-40°C to 120°C)
A99BC-300C ¹	PTC Temperature Sensor: Standard probe 2 in. (5.1 cm) with 9.8 ft (3.0 m) high-temperature silicon cable; ambient operating temperature range: -40°F to 248°F (-40°C to 120°C)
A99BC-500C ¹	PTC Temperature Sensor: Standard probe 2 in. (5.1 cm) with 16.4 ft (5.0 m) high-temperature silicon cable; ambient operating temperature range: -40°F to 248°F (-40°C to 120°C)
A99BC-1500C ¹	PTC Temperature Sensor: Standard probe 2 in. (5.1 cm) with 49.2 ft (15.0 m) high-temperature silicon cable; ambient operating temperature range: -40°F to 248°F (-40°C to 120°C)
A99CB-200C	PTC Temperature Sensor: Extended probe 6 in. (15.2 cm) with 6.6 ft (2.0 m) PVC cable; ambient operating temperature range: -40°F to 212°F (-40°C to 100°C)
A99CB-600C	PTC Temperature Sensor: Extended probe 6 in. (15.2 cm) with 19.7 ft (6.0 m) PVC cable; ambient operating temperature range: -40°F to 212°F (-40°C to 100°C)

¹ When any A99 Series Temperature Sensor is connected to a standard A421 Control model, the range of displayed temperature values is restricted to -40°F to 212°F or -40°C to 100°C.

Table 7: Accessories

Product code	Description
BKT287-1R	12 in. (305 mm) long DIN rail section
BKT287-2R	36 in. (914 mm) long DIN rail section
PLT344-1R	Two end clamps for DIN rail sections
A99-CLP-1	Surface mounting clip for A99B and A99C Series Temperature Sensors
SHL10-603R	Sun shield for A99B and A99C Series Temperature Sensors
BOX10A-603R	PVC enclosure for A99B and A99C Series Temperature Sensors
WEL11A-601R	Copper and brass immersion well for applying sensor in fluid applications
TE-6300W-102	Stainless steel immersion well for applying A99 sensors in fluid applications. A99CB Type sensors with extended probe with this immersion well.

Technical specifications

Table 8: A421 Series Electronic Temperature Controls with power cords Technical Specifications

Specification	Description
Power consumption	1.8 VA maximum
Supply power	110/120 VAC, 50/60 Hz
Ambient conditions	Operating: Type 1 models: -40°F to 150°F (-40°C to 66°C), 0% to 95% RH noncondensing Type 4X models: -40°F to 140°F (-40°C to 60°C), 0% to 95% RH noncondensing Shipping and storage: All models: -40°F to 185°F (-40°C to 85°C), 0% to 95% RH noncondensing
Temperature control range	-40°F to 212°F or -40°C to 100°C
Input signal	1,035 ohm at 77°F (25°C) for A99 PTC temperature sensors
Sensor offset range	±5°F or ±3°C
Enclosure material	Type 1, IP20 high-impact thermoplastic or Type 4X, IP66 watertight, corrosion-resistant, high-impact thermoplastic Note that on the type 4x enclosures, the cover screws must be torqued to 10 to 12 in-lb (1.1 N·m to 1.4 N·m) to achieve type 4X rating.
Compliance	North America: cULus Listed; UL 60730, File E27734, Vol. 1; FCC Compliant to CFR47, Part 15, Subpart B, Class B Industry Canada (IC) Compliant to Canadian ICES-003, Class B limits

Table 9: A421 Temperature Control with power cords output relay contacts electrical ratings

A421	
Agency and file	UL 60730
Applied AC voltage at 50/60 Hz	120 VAC
Full load amperes LC/LNO	12 A

Table 9: A421 Temperature Control with power cords output relay contacts electrical ratings

A421	
Locked rotor amperes LC/LNO	72 A
Resistive amperes LC/LNO	10 A
Pilot duty VA LC/LNO	125 VA

Table 10: UL conformity declaration information

Information	Description
Purpose of control	Sensing control / operating control
Construction of control	Electronic free-standing control, in-line cord control
Number of cycles	30,000 cycles
Method of mounting control	Mounting screws or DIN rail
Method of providing earthing	Attachment plug
Type of cord connection	Type Y
Type 1 or type 2 action	Type 1.B (Micro-disconnection)
External pollution situation	All models: A421 [] B: Pollution degree 3 All models: A421 [] E: Pollution degree 4
Internal pollution situation	Pollution degree 2
Heat and fire resistance category	D
Rated impulse voltage	4,000 V
Ball pressure temperature	128°C
Cover screw torque requirements instruction	All models: A421 [] E: To maintain type 4X / IP66 rating, tighten enclosure screws to: 10-12 in·lb

Table 11: A99B Series Positive Temperature Coefficient Sensors Technical Specifications

Specification	Description
Sensing range ¹	Type A99BA and A99BB: -40°F to 212°F (-40°C to 100°C) Type A99BC: -40°F to 248°F (-40°C to 120°C)

Table 11: A99B Series Positive Temperature Coefficient Sensors Technical Specifications

Specification	Description
Reference resistance	1,035 ohms at 77°F (25°C) and 855 ohms at 32°F (0°C)
Accuracy	0.9°F (0.5°C) between 5°F and 167°F (-15°C and 57°C). Refer to the <i>A99B Series Temperature Sensors Product/Technical Bulletin (LIT-125186)</i> for accuracy outside of this temperature range.
Sensor construction	Probe: Stainless steel
Sensor cable sheath	Type A99BA: Shielded PVC cable Type A99BB: PVC cable Type A99BC: High temperature silicon cable
Wire gauge	22 AWG
Ambient operating conditions	Type A99BA and A99BB: -40°F to 212°F (-40°C to 100°C); 0% to 100% RH, condensing Type A99BC: -40°F to 248°F (-40°C to 120°C); 0% to 100% RH, condensing
Ambient storage conditions	Type A99BA and A99BB: -40°F to 221°F (-40°C to 105°C); 0% to 100% RH, condensing Type A99BC: -40°F to 266°F (-40°C to 130°C); 0% to 100% RH, condensing
Shipping weight	1.4 oz (41 g) for 6 1/2 ft (2 m) sensor
Accessories	See Table 7

¹ When any A99 Series Temperature Sensor is connected to a standard A421 Control model, the range of displayed temperature values is restricted to -40°F to 212°F or -40°C to 100°C.

The performance specifications are nominal and conform to acceptable industry standards. For application at conditions beyond these specifications Johnson Controls shall not be liable for damages resulting from misapplication or misuse of its products.

North American emissions compliance

United States

This equipment has been tested and found to comply with the limits for a Class B digital device, pursuant to Part 15 of the FCC Rules. These limits are designed to provide reasonable protection against harmful interference in a residential installation. This equipment generates, uses and can radiate radio frequency energy and, if not installed and used in accordance with the instructions, may cause harmful interference to radio communications. However, there is no guarantee that interference will not occur in a particular installation. If this equipment does cause harmful interference to radio or television reception, which can be determined by turning the equipment off and on, the user is encouraged to try to correct the interference by one or more of the following measures:

- Reorient or relocate the receiving antenna.
- Increase the separation between the equipment and receiver.
- Connect the equipment into an outlet on a circuit different from that to which the receiver is connected.
- Consult the dealer or an experienced radio/TV technician for help.

Canada

This Class (B) digital apparatus meets all the requirements of the Canadian Interference-Causing Equipment Regulations. Cet appareil numérique de la Classe (B) respecte toutes les exigences du Règlement sur le matériel brouilleur du Canada.

Single point of contact

APAC	Europe	NA/SA
JOHNSON CONTROLS C/O CONTROLS PRODUCT MANAGEMENT NO. 32 CHANGJIJANG RD NEW DISTRICT WUXI JIANGSU PROVINCE 214028 CHINA	JOHNSON CONTROLS WESTENDHOF 3 45143 ESSEN GERMANY	JOHNSON CONTROLS 507 E MICHIGAN ST MILWAUKEE WI 53202 USA

For more contact information, refer to www.johnsoncontrols.com/locations.