



3825 Ohio Avenue, St. Charles, Illinois 60174  
1-800-SENSOR2, FAX: 630-377-6495

## **B402B Plug-in Detector Base**

For use with the following smoke detectors:  
1451, 2451, and 2451TH

---

### **Specifications**

Base Diameter:	6.2 inches (15.7 cm)
Base Height:	1.1 inches (2.8 cm)
Weight:	0.3 lb. (130 g)
Mounting:	4 inch square box with or without plaster ring. Min. Depth: 1.5 inches 4 inch octagon box. Min. Depth: 1.5 inches 3-1/2 inch octagon box. Min. Depth: 1.5 inches
Operating Temperature Range:	0° to +49°C (32° to 120°F)
Operating Humidity Range:	10% to 93 % Relative Humidity, Non-condensing

### **Electrical Ratings — includes base and detector**

System Voltage:	24 VDC
Maximum Ripple Voltage:	4 Volts peak to peak
Start-up Capacitance:	0.02 $\mu$ F Maximum
Standby Ratings:	20 VDC Minimum 29 VDC Maximum 120 $\mu$ A Maximum
Alarm Ratings:	17 mA Minimum 36 mA Maximum
Reset Voltage:	1.4 VDC Minimum
Reset Time:	0.3 Seconds Maximum (If used, the RA400 remote lamp operates within the specified detector alarm currents.)
Start-up Time:	34.0 Seconds Maximum
Relay Contact Ratings	
Resistive or Inductive (60% Power Factor):	
Form A:	2.0A @ 30 VAC/DC
Form C:	2.0A @ 30 VAC/DC 0.6A @ 110 VDC 1.0A @ 125 VAC

---

### **Before Installing**

Please read the System Sensor manual I56-407, *Guide for Proper Use of System Smoke Detectors*, which provides detailed information on detector spacing, placement, zoning, wiring, and special applications. Copies of this manual are available at no charge from System Sensor. (For installations in Canada, refer to CAN4-S524, *Standard for the Installation of Fire Alarm Systems*, and CEC Part 1, Sec. 32.)

**NOTICE:** This manual should be left with the owner/user of this equipment.

**IMPORTANT:** The detector used with this base must be tested and maintained regularly following NFPA 72 requirements. The detector used with this base should be cleaned at least once a year.

### **General Description**

The plug-in detector base B402B is used with System Sensor model 2451 and 2451TH photoelectronic detector heads, and model 1451 ionization detector head. The capability of plugging these detectors into a variety of special bases makes them more versatile than equivalent direct-wired models. Refer to the System Sensor catalog for other available plug-in detector bases.

This B402B base is intended for use in 4-wire systems, with screw terminals provided for power, remote annunciator, and relay contact connections. These bases also contain a resistor to provide current limiting in the alarm state.

## Mounting

This detector base mounts directly to 3½-inch and 4-inch octagon boxes, and 4-inch square boxes (with or without plaster). To mount the base, remove the decorative ring by rotating it in either direction to unhook the snaps before separating the ring from the base. Use the screws supplied with the junction box to attach the base to the box through the appropriate slots in the base (see Figure 1). Position the decorative ring around the base and rotate it in either direction until the ring snaps into place.

## Installation Guidelines

All wiring must be installed in compliance with the National Electrical Code, all applicable local codes, and any special requirements of the authority having jurisdiction, using the proper wire size. The conductors used to connect smoke detectors to control panels and accessory devices should be color-coded to reduce the likelihood of wiring errors. Improper connections can prevent a system from responding properly in the event of a fire.

For signal wiring (the wiring between interconnected detectors), it is recommended that the wire be no smaller than 18 gauge (1.0 square mm). The screws and clamping plate in the base can accommodate wire sizes up to 12 gauge (2.5 square mm). For best system performance, the power (+ and -) loop wire should be twisted pair and installed in separate grounded conduit to minimize the effects of electrical interference.

Smoke detectors and alarm system control panels have specifications for allowable loop resistance. Read the manual for the control to determine the total loop resistance allowed before wiring the detector loops.

Locate installations where normal ambient temperature does not exceed 100°F.

## Wiring Instructions

Wire connections are made by stripping approximately 3/8" (1 cm) insulation from the end of each wire, sliding the bare end of the wire under the clamp plate, and tightening the clamping plate screw. Use the strip gauges molded into the inside and underside of the base for ease of wiring to terminals 1 through 5 and to terminals 12 through 14, respectively.

The zone wiring of the detector base should be checked before installing the smoke detector head. To make this possible, this base contains a special-type shorting jumper. After the detector base is wired and attached to the electrical box, make sure that the shorting spring is in contact with the base of terminal 3. This temporary connection

**Figure 1. Mounting base to box:**

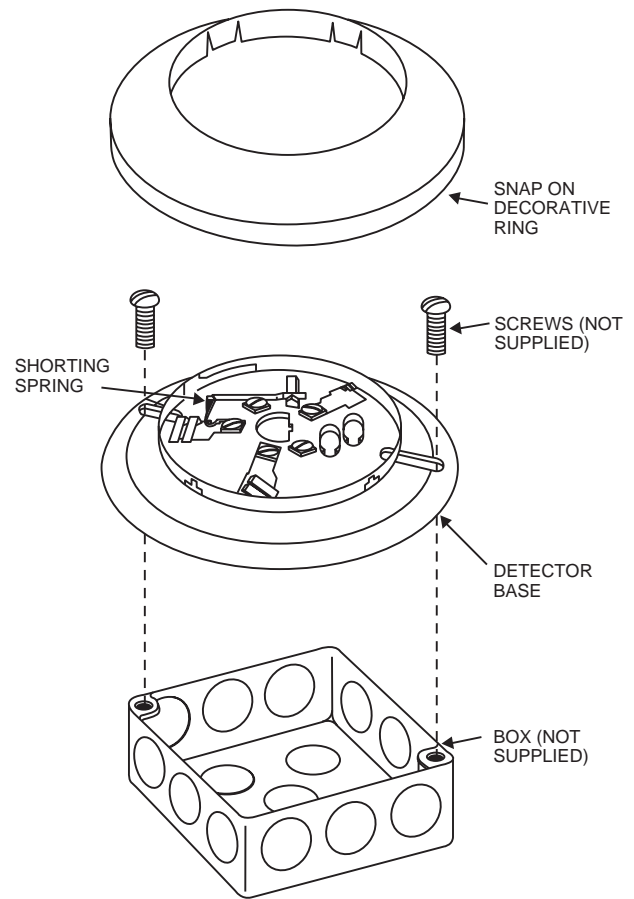

A78-1175-01

shorts the positive-in and positive-out leads and permits the wiring of the loop to be checked for continuity.

Once all the detector bases have been wired and mounted, and the loop wiring has been checked, the detector heads may be installed in the bases. The shorting spring in the base will disengage automatically when the detector head is removed from the base. DO NOT remove the shorting spring since it reengages as the detector head is turned into the base, completing the circuit.

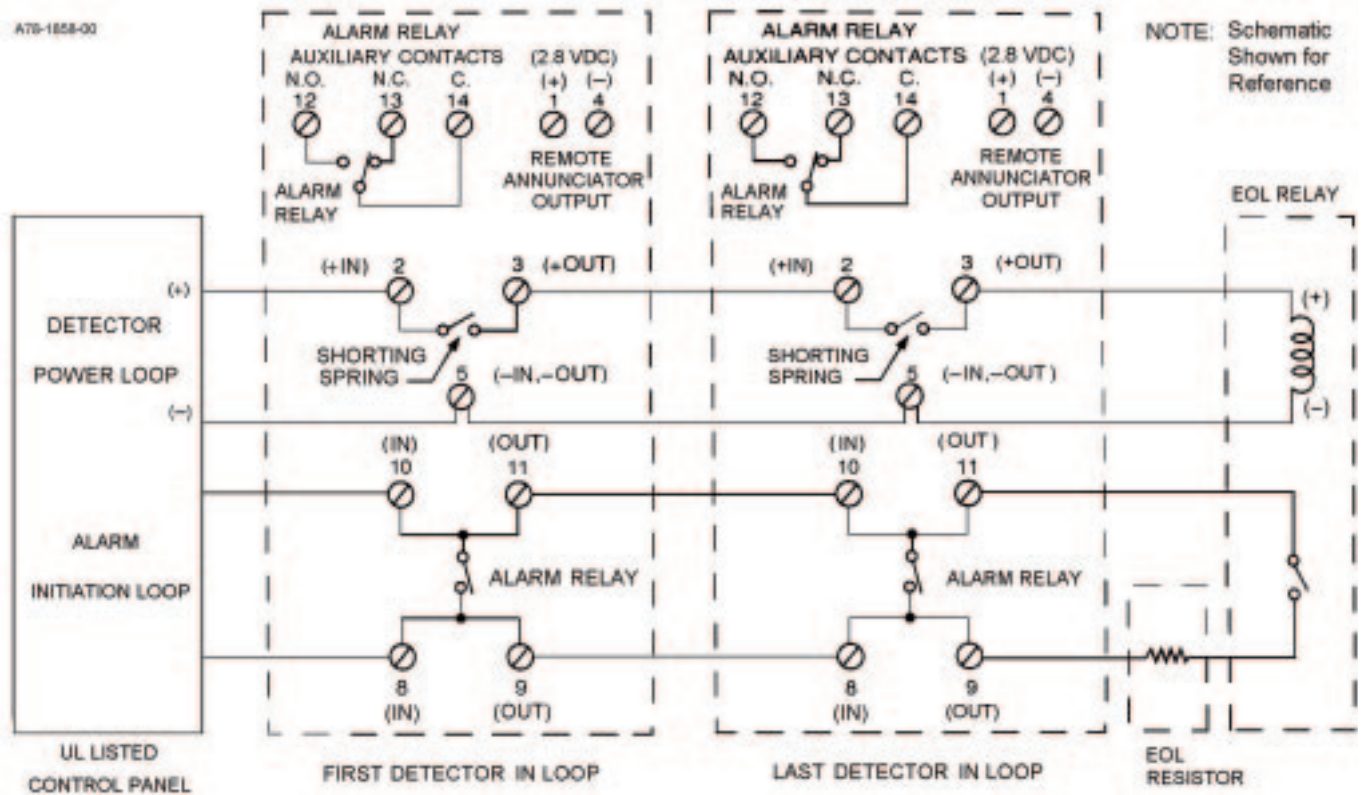

**NOTE:** For wiring or releasing device, refer to manufacturer's installation instructions.

**CAUTION**

For system supervision—DO NOT use looped wire under terminals 2, 3, and 5. Break wire run to provide supervision of system.

**Figure 2. Typical wiring diagram:**

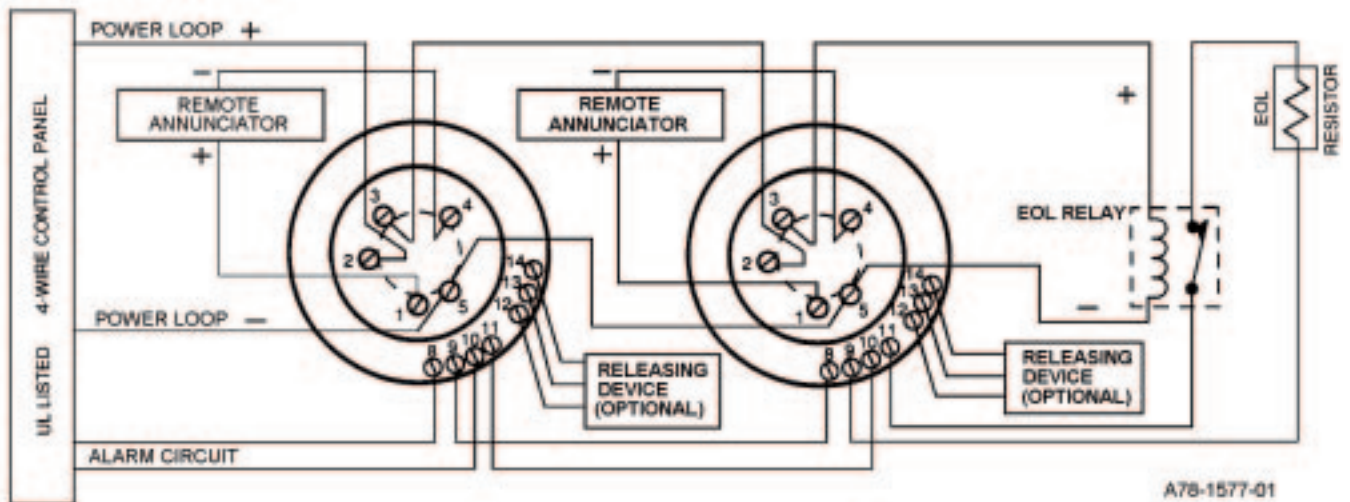

## Tamperproof Feature

**CAUTION**

Do not use the tamperproof feature if the XR5 removal tool is to be used.

This detector base can be made tamperproof to prevent the removal of the detector head without the use of a tool. To activate this feature, break off the tab on the detector base as shown in Figure 3A, then install the detector. To remove the detector from the base once the tamperproof feature has been activated, place a small-bladed screwdriver into

the small hole on the side of the base and push the plastic lever away from the detector head (see Figure 3B). This will allow the detector to be rotated counterclockwise for removal.

**NOTE:** Head removal after the tamperproof feature has been activated first requires removal of the decorative ring.

The tamperproof feature may be defeated by breaking and removing the plastic lever from the base; however, this prevents ever using the feature again.

**Figure 3A. Activating tamperproof feature:**

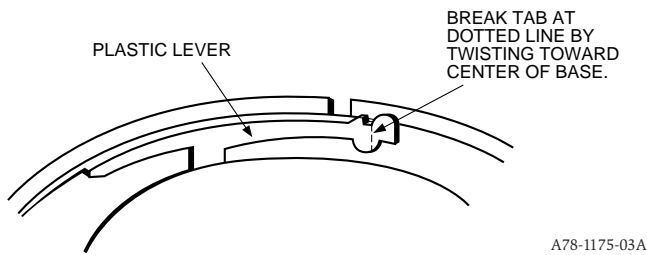

**Figure 3B. Removing detector head from base:**

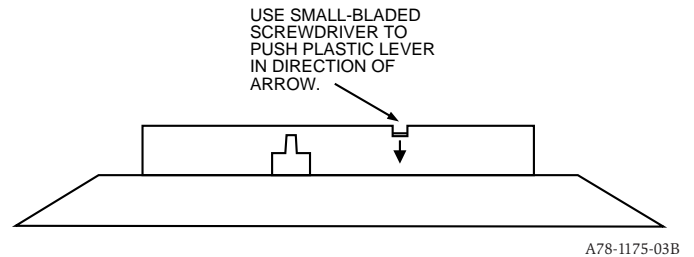

## Please refer to insert for the Limitations of Fire Alarm Systems

### Three-Year Limited Warranty

System Sensor warrants its enclosed smoke detector base to be free from defects in materials and workmanship under normal use and service for a period of three years from date of manufacture. System Sensor makes no other express warranty for this smoke detector base. No agent, representative, dealer, or employee of the Company has the authority to increase or alter the obligations or limitations of this Warranty. The Company's obligation of this Warranty shall be limited to the repair or replacement of any part of the smoke detector base which is found to be defective in materials or workmanship under normal use and service during the three year period commencing with the date of manufacture. After phoning System Sensor's toll free number 800-SENSOR2 (736-7672) for a Return Authorization number, send defective units postage prepaid to: System

Sensor, Repair Department, RA # \_\_\_\_\_, 3825 Ohio Avenue, St. Charles, IL 60174. Please include a note describing the malfunction and suspected cause of failure. The Company shall not be obligated to repair or replace units which are found to be defective because of damage, unreasonable use, modifications, or alterations occurring after the date of manufacture. In no case shall the Company be liable for any consequential or incidental damages for breach of this or any other Warranty, expressed or implied whatsoever, even if the loss or damage is caused by the Company's negligence or fault. Some states do not allow the exclusion or limitation of incidental or consequential damages, so the above limitation or exclusion may not apply to you. This Warranty gives you specific legal rights, and you may also have other rights which vary from state to state.