

## A-4000 Oil Indicator

The A-4000 Oil indicator is a calibrated measuring instrument used to detect aerosol-mist levels of oil entrainment that may be present in compressed air systems. Sensitivity of the indicator is limited only by the total number of hours it is allowed to remain on the air supply system. The indicator is sensitive enough to measure a concentration of oil entrainment as low as .01 PPM (.012 mg/m<sup>3</sup>) in a compressed air system. It can be used in systems with line pressures between 10 and 125 PSIG (70 and 875 kPa).

### Application

Oil entrainment in the control air supply to the pressure reducing valve may eventually have an adverse effect on the control system performance. Since some oil entrainment is inherent to lubricated compressors, all oil lubricated compressor installations must include factory approved oil filters to be reliably acceptable. The indicator can be used in two ways. Either it can be used to check for oil carryover from the compressor or it can be used to check out any filtered air supply source before connecting it to the system and also every few months after the system becomes operative. Once the needle valve of the oil indicator has been opened, one continuous uninterrupted exposure is recommended for greatest accuracy.

### Operation

When the needle valve of the oil indicator is open, less than 2 SCIM/PSIG (.08 mL/s/kPa) will flow through the calibrated plastic tube. Any oil present in the air will then carry a red oil soluble dye up the tube, coloring a white material in the tube. The rate of color travel will be proportional to the amount of oil present. The parts per million (PPM) value of oil entrained in the air can be determined using the conversion chart included with the instrument. After use, the needle valve should be closed and left in the line and the cartridge removed. At the time of the next test, a replacement cartridge will need to be installed on the needle valve fitting.



Fig. 1: A-4000 Oil Indicator Installed in Air Line

### Specifications

<b>Product</b>	A-4000-120 Oil Indicator and Needle Valve Assembly
<b>Air Consumption</b>	1.9 SCIM/PSIG (.07 mL/s/kPa)
<b>Maximum Temp. Rating</b>	120F (49°C) Internal and Ambient
<b>Pressure Range</b>	10 to 125 PSIG (70 to 875 kPa)
<b>Oil Concentration Range (W/W*)</b>	0 to 25 PPM By Weight @ 68F (20°C) 0 to 3 oz/100,000 SCF 0 to 30 mg/m <sup>3</sup>
<b>Accessory (Order Separately)</b>	A-4000-121 Oil Indicator Replacement Cartridge
<b>Shipping Weight</b>	0.2 lbs

\*W/W = Weight of oil per weight of air

*The performance specifications are nominal and conform to acceptable industry standards. For application at conditions beyond these specifications, consult the local Johnson Controls office. Johnson Controls, Inc. shall not be liable for damages resulting from misapplication or misuse of its products.*

## Installation

In order for the oil indicator to properly measure a given oil entrainment, sufficient exposure time is required. The length of exposure time is inversely proportional to the pressure at the point of installation. When using the indicator to check for oil carryover from the compressor, it should be installed at the discharge of the tank. When using the indicator to measure oil entrainment in the air supply system, it should be installed between the oil filter and the pressure reducing valve (PRV). At this point, dry high pressure air will be present, resulting in the best accuracy and fastest indication.

**Note: In humid air, moisture may wash traces of dye up the tube, creating a light pink area above the dark red area. When calculating oil entrainment, measure only to the top of the dark red column. Locations involving excessive moisture, temperature, or velocity should be avoided. The indicator valve should remain closed except during the measuring period. For pressures above 125 PSIG (875 kPa) or below 10 PSIG (70 kPa), consult the factory.**

**▲ WARNING:** If the pressure exceeds 125 PSIG or the retaining nut is loosened, the oil indicator tube could blow out of the compression fitting, creating a hazardous condition.

The indicator must be mounted within 45° of an upright position for best possible performance. Fittings (1/8 in. N.P.T.) are provided on both high and low pressure sides of all A-4000 series filter and reducing station assemblies. Any other mounting location will require a 1/8 in. N.P.T. mounting tee as shown in Fig. 1.

Before installing a replacement cartridge, first check that the needle valve on the existing installation is closed all the way by making sure that the needle valve handle (see Fig. 2) is fully rotated in a clockwise direction. Install the replacement cartridge (see Fig. 3) by tightening the lower 1/8 in. nut in place.

**Note: Do not disturb the factory adjusted torque on the upper 3/16 in. retaining nut that holds the plastic tube in place. Also make sure that the indicator scale can be conveniently viewed before tightening the cartridge in place.**

## Readings and Measurements

1. Before taking a measurement, fill out the record tag furnished with the oil indicator. Record the line pressure or the average pressure (if it varies at the point of installation).
2. Fully rotate the needle valve handle (see Fig. 2) counterclockwise to open it and record the time that the needle valve was opened on the record tag. Slide the record tag over the oil indicator to avoid misplacing it.
3. At the following times and locations, visual inspections of the oil indicators should be made:
  - A. When checking for compressor oil carryover, inspection should be made after 4 hours at the compressor discharge.
  - B. When checking for oil entrainment in the air supply, inspection should be made after 40 hours between the oil filter and the PRV.

4. Judging from the rate of color travel established at the time of the first inspection, schedule the final reading of the indicator (and needle valve shut-off) at approximately 1 unit (marked "1.0" on the scale), and preferably not more than 1-1/2 units (marked "1.5" on the scale).
5. Close the needle valve, remove the oil indicator cartridge, and record the time. Leave the needle valve in the air line for future testing purposes.
6. Record the units of color travel (as read from the indicator scale) and the total time in hours.

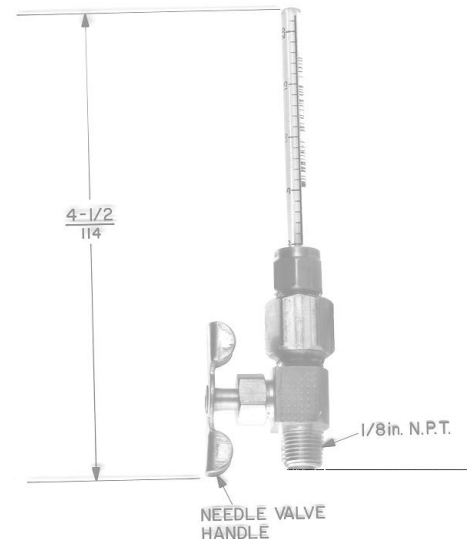

**Fig. 2: Dimensions in./mm**

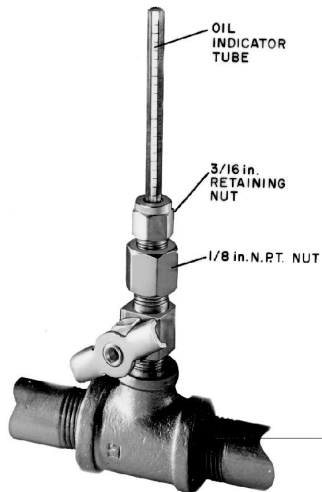
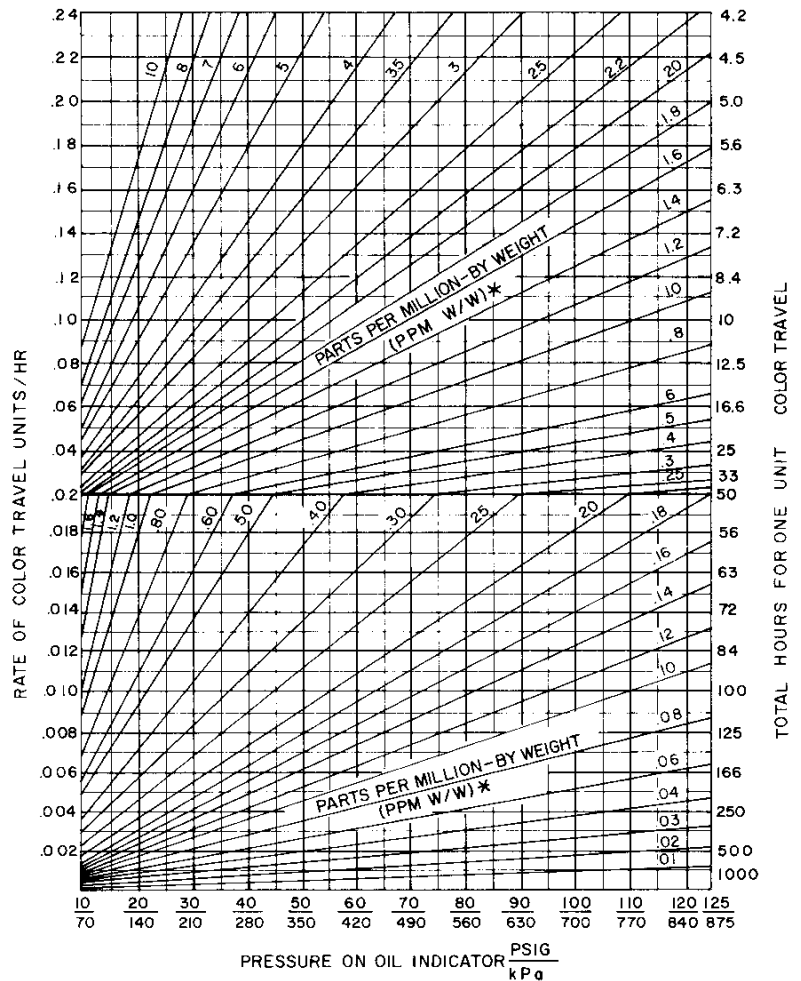

**Fig. 3: A-4000-121 Replacement Cartridge**

### Oil Concentration Determination (See Fig. 4)

1. If color travel is 1 unit at the final reading time, find the Total Hours on the right side of the conversion chart and the Pressure on the bottom of the chart. The point where Hours and Pressure intersect is the parts per million of oil concentration.
2. If the final reading occurs at other than 1 unit of color travel, divide the units traveled by the total hours to find the Rate of Color Travel.
3. Find the Rate of Color Travel on the left side of the conversion chart and the Pressure on the bottom of the chart. The point where Rate and Pressure intersect is the parts per million of oil concentration.

For any Rate of Color Travel beyond 0.24 units/hr., the measured rate should be divided by any factor which will bring it into the range of the chart. This number should then be used to determine the oil concentration (PPM). This concentration must then be multiplied by the same factor used previously to



\*W/W = Weight of oil per weight of air  
 Note: Multiply PPM by 0.12 to obtain oz/100,000 SCF  
 Multiply PPM by 1.2 to obtain mg/m<sup>3</sup>

**Fig. 4: Conversion Chart for Oil Indicator**

determine the actual oil concentration.

**Example:** The Rate of Travel on the high pressure side of a PRV (80 PSIG [560 kPa]) is found to be 0.5 units/hr. Divide this rate by five (0.5 ÷ 5 = 0.1 units/hr) to bring it into the range of the conversion chart. Locate this new rate on the chart, showing a concentration of 1.4 PPM. Multiply this concentration by the previous factor (1.4 × 5 = 7.0 PPM) to obtain the actual oil concentration in the air being tested.

---

# Notes

JOHNSON  
CONTROLS

**Controls Group**  
507 E. Michigan Street  
P.O. Box 423  
Milwaukee, WI 53202

Printed in U.S.A.