

V-4000 Small Pneumatic Actuator for Small Control Brass Valves

The V-4000-1 Small Pneumatic Actuator is designed to position modulating plugs of chilled or hot water (up to 200° F) control valves accurately in response to a pneumatic signal from a controller. It is tailored for small terminal unit valve applications, and can be used on Johnson Controls brass valves as a direct replacement for oval top actuators (VT Series and oval top series).

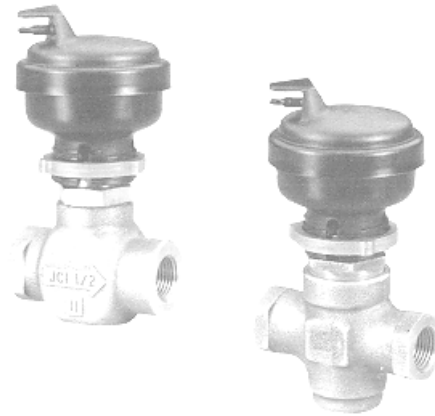

Figure 1: V-4000-1

Features and Benefits	
<input type="checkbox"/> Directly replaces field installed V-3854 and V-3800 models	Simple, low-cost upgrade
<input type="checkbox"/> Glass-reinforced nylon housing	Long lasting and corrosion resistant
<input type="checkbox"/> Compact design	Fits in tight mounting spaces
<input type="checkbox"/> Easy-mount design	Requires no tools for mounting, even in "blind" installations
<input type="checkbox"/> Low cost	Repairs by unit replacement
<input type="checkbox"/> Snap-on mounting with retaining nut	Assures correct alignment
<input type="checkbox"/> Pneumatic connection readily positioned for easy access	Simplifies tubing routing

Application Overview

The V-4000-1 is designed for use with Johnson Controls small brass valves—normally open, normally closed, and three-way mixing valve styles.

The Small Pneumatic Actuator (V-4000-1) is designed with a snap-on, hand tightened mounting that uses no set screws **and requires no tools**. It is designed to field replace oval-top and other actuators installed on V-3854, V-3800, and other valves.

Operating Principles

Air pressure from a pneumatic controller is applied to the diaphragm of the actuator, which moves a piston against the valve stem. The piston will move the valve stem and plug until the diaphragm pressure balances the valve return spring force and the fluid forces. These fluid forces will cause the operating range to shift from the nominal spring range. Reducing the air pressure to the diaphragm of the actuator allows the spring to return the valve plug to its normal position.

This actuator is based on a rolling diaphragm design. The rolling diaphragm provides a constant effective area throughout the valve stem stroke. The actuator housing is constructed of sturdy, glass-reinforced nylon. Due to the simplicity of the design, it is more economical to replace the actuator than to repair it. Therefore, no repair parts are needed or provided.

Installation Instructions

Assembling the actuator. No tools are required for this operation.

1. Before mounting the actuator to the valve, locate the retaining nut in the full up position, completely disengaged from the yoke threads (Figure 5).

Note: The actuator cannot be mounted or removed if the retaining nut is located on the yoke threads.

2. The actuator can be mounted on cage trim or VT valves:

- If the actuator is to be assembled to a VT valve, insure that the plastic spring seat retainer is in place (Figure 5). Use the retainer furnished with the actuator if there is no retainer in the valve. Insert the retainer so that the projection at the bottom of the retainer snaps into the keyway at the bottom of the spring seat. When properly inserted, the top of the retainer will be below the top of the spring seat.
- If the actuator is being mounted on a cage trim valve, check the spring gauge height before mounting the actuator. This measurement cannot exceed 1-13/16 inches (46 mm) as shown in Figure 5. If the gauge height is greater than 1-13/16 inches (46 mm), adjust it to this value.

3. Tilt the actuator and slide it over the valve spring as shown in Figure 2.
4. Tilt the actuator slightly, and snap the yoke over the valve bonnet as shown in Figures 3 and 4.
5. Rotate top of actuator so that the air fitting is in the desired position.
6. Secure the actuator to the valve by turning the retaining nut onto the yoke threads. While holding the actuator in position, turn down the nut until it no longer turns freely. Then tighten by hand one additional turn.



CAUTION: Hand tighten nut only — do not use tools.

Removing the actuator

1. Remove the polytubing from the barb. The tube may have to be cut.
2. While holding the actuator, turn the retaining nut counterclockwise (as seen from above) until it is in the area above the threads and below the yoke.
3. Tilt the actuator and snap it off the bonnet.
4. Lift the actuator off the valve. On cage trim valves, tilt the actuator to clear the valve upper spring seat.



Figure 2: Tilt the actuator over the spring and slide into place.



Figure 3: Tilt the actuator over the bonnet.

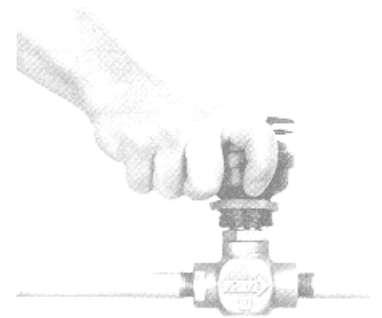

Figure 4: Snap the actuator into position.

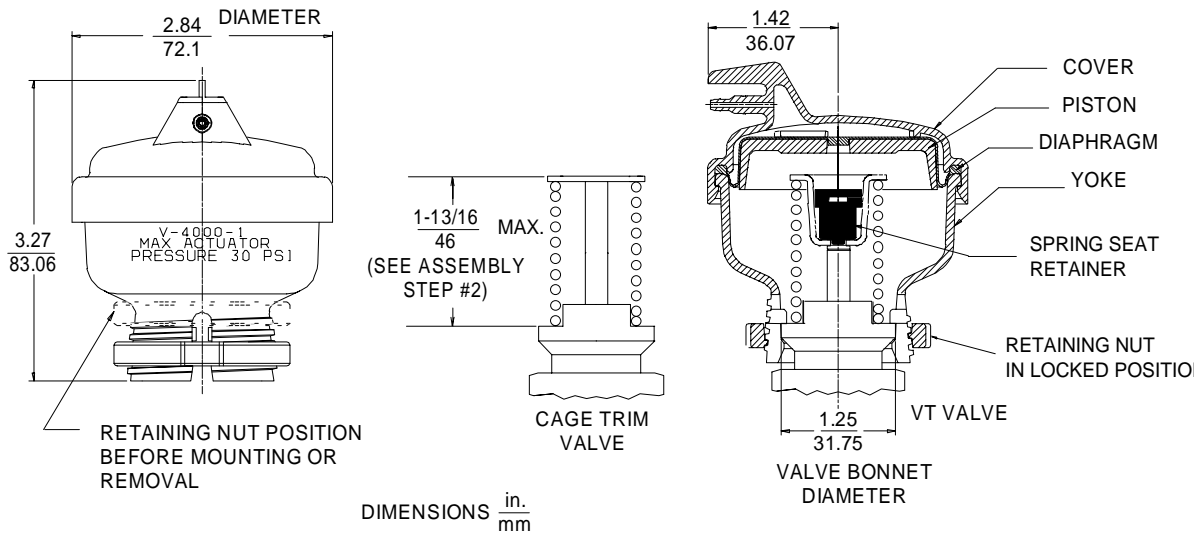

Figure 5: Small Pneumatic Actuator Dimensions

Specifications

Ambient Temperature Limits	-20° to 150°F (-29° to 66°C)
Relative Humidity	5 to 90% RH
Fluid Operating Temperature Limits	35 to 200°F (2 to 93°C)
Storage Condition Limits	-20 to 150°F (-23 to 66°C) 5 to 95% RH
Dimensions (H x Diameter)	3.27 inch x 2.84 inch diameter (83.1 mm x 72.1 mm diameter)
Weight	3.4 ounces (96 grams)
Maximum Control Pressure	30 PSIG (210 kPa)
Control Signal Air Connection	Dual Barbed Fitting for 5/32 or 1/4 inch O.D. Tubing
Effective Diaphragm Area	4 square inches (2581 square mm)
Materials	Yoke and Cover: Glass-reinforced nylon Piston: Glass-reinforced nylon Diaphragm: Fabric reinforced synthetic rubber Retaining Nut: Chromate-coated Zinc

The performance specifications are nominal and conform to acceptable industry standards. For application at conditions beyond these specifications, consult the local Johnson Controls office. Johnson Controls, Inc. shall not be liable for damages resulting from misapplication or misuse of its products.



Controls Group
507 E. Michigan Street
P.O. Box 423
Milwaukee, WI 53201

FAN 977
Valve and Actuator Manual
Printed in U.S.A.