



TECHNICAL DOCUMENTATION FOR ONICON INSERTION FLOW METERS

This file contains the following:

- 1. ONICON Flow Meter Ordering Guide For Johnson Controls**
- 2. Flow Meter Order Form**
- 3. Insertion Turbine Flow Meter Installation and Adjustment Guide**

Please note that Excel® spreadsheet versions of our order forms are available on our web site: www.onicon.com

*ONICON Incorporated is proud to be
a partner in Johnson Controls'
Preferred Supplier Program*

ONICON FLOW METER ORDERING GUIDE



I. MODEL NUMBERING SYSTEM

Format: F(B)-XX YY

SERIES ←

→ **OUTPUT SIGNAL**

F-11 Single Turbine, Insertion Type

For 1¼" – 72" pipes with fully developed flow profile (20 – 30 straight pipe diameters, based on upstream obstruction)
Note: can be used in 1" copper with Onicon install kit.

F-12 Dual Turbine, Insertion Type

For 2½" – 72" pipes with 15 straight pipe diameters or less. The most popular series for demanding HVAC applications.

FB-12 Bi-Directional, Insertion Type

For bi-directional applications in 2½" – 72" pipes. Designed for primary/secondary decoupler (bypass) and thermal storage applications.

F-13 Inline Turbine Meter

For ¾" and 1" applications

00 Frequency Output (15 V pulse)

For connection to Onicon display or BTU meter only. Signal is too fast for most building control systems (0-300 hz).

10 Analog Output (non-isolated)

Provides both 4-20 mA and 0-10 V outputs. Most commonly used output type. (3-wire connection)

11 Isolated Analog Output

Provides both 4-20 mA and 0-10 V outputs. Signal ground is isolated from power supply and pipe ground. (4-wire connection)

20 Divided Output (dry contact)

Provides an isolated binary/digital output. Signal is divided to limit the maximum frequency. For rate/totalization.

30 Scaled Output (dry contact)

Provides an isolated binary/digital output scaled to provide one pulse per desired unit volume (i.e.: 1 pulse = 10 gal.). Ideal for totalization applications.

Example: "F-1210" = Dual turbine, analog output
ONICON Model Number = Item number

II. OPTIONAL FEATURES

Refer to flow meter catalog page for standard features. Optional features are listed below and must be ordered separately. NOTE: ½" FIP fitting for conduit connector and weather-tight enclosure are now standard features; high temp option is provided for HW meters at no additional charge.

OPTIONAL FEATURE:	ITEM NUMBER:	NOTES:
* 316 SS wetted metal parts for F-11, F-12 or FB-12 series. Use item number for appropriate series.	F-1199-STANLS F-1299-STANLS FB-1299-STANLS	For industrial/process applications, high temp HW, and submersible applications
10 ft. liquid-tight conduit and connectors	F-OPT1-CONDUIT	This option NOT required for conduit connection. Provides conduit & fittings.
25 ft. standard cable	F-OPT2-25FT	Provides cable length indicated in addition to 10 ft. standard cable length (add'l cable is provided separately)
50 ft. standard cable	F-OPT3-50FT	
100 ft. standard cable	F-OPT4-100FT	
10 ft. plenum cable with inline DIN connector	F-OPT5-PLENUM	For installations with exposed wire runs in an air plenum – no conduit. Inline DIN connector is approx. 12" from meter, with remaining cable on other side of the connector.
25 ft. plenum cable with inline DIN connector	F-OPT6-25FTPL	
50 ft. plenum cable with inline DIN connector	F-OPT7-50FTPL	
100 ft. plenum cable with inline DIN connector	F-OPT8-100FTPL	
* Submersible electronics enclosure	F-OPT9-SUBMER	For installations in areas subject to intermittent submersion. Also requires 316SS wetted parts.

* Not available for F-13 Series inline meters.

III. INSTALLATION HARDWARE

Purchase of installation kit with the flow meter (insertion type) is **strongly recommended** to prevent installation problems. Refer to catalog page for most common installation kits; complete list on next page.

IV. CALIBRATION DATA

Pipe size, material, flow range, etc. is required for all meters. Use order form and fax or e-mail directly to ONICON Incorporated. Reference project name and number on order form.

V. PERIPHERAL DEVICES AVAILABLE

Display Modules: See D-1200 and D-1500 Series Display Modules

BTU Meters: See System-1 and System-2 Series BTU Meters

ORDER FORM: Insertion Flow Meters



Please provide ship to & bill to information on your purchase order

Company Name: and Location (city,ST)	Note: Standard lead time for meters is two weeks, contact factory if shorter lead time is required.
Contact Name:	Requested Delivery Date:
Purchase Order #:	Ship Meters Via: Ground, 3-day, 2-day, Overnight
Project Name: and location (city,ST)	Ship install kits in advance? YES or NO
Specified By: (Engineering firm, city, ST)	Ship Kits Via: Ground, 3-day, 2-day, Overnight

APPLICATION INFORMATION:

	Item #1	#2	#3	#4	#5
FLOW METER MODEL:					
METER TAG INFORMATION:					
APPLICATION TYPE: (CHW, HW, make-up, boiler feed, etc.)					
LIQUID TYPE: (water, x% ethylene glycol, brine, etc.)					
PIPE SIZE (nominal):					
PIPE MATERIAL: (i.e: black iron, copper tube, pvc, etc.)					
PIPE SCHEDULE, TYPE, or I.D.: (i.e.: sch 40, type L, etc.)					
MAX. OPERATING TEMPERATURE: * Required for hot water systems only					
TYPICAL FLOW RATE: Expected "typical" flow rate for the system					
DESIGN MAXIMUM FLOW RATE: Maximum flow per system design					
ANALOG FULL SCALE FLOW RATE: For Analog Output (i.e.: 20 mA = X gpm)					
ANALOG OUTPUT: For Analog Models Only Choose from: 4-20 mA, 0-10 V, 0-5 V					
MAXIMUM OUTPUT FREQUENCY: For Frequency, Divided, or Scaled Output					
SCALE FACTOR: For Scaled Output Models (1 Pulse = X gal, L, etc.)					

AVAILABLE OPTIONS: *These affect price. refer to price sheet for details.*

NOTES:

* 316 SS wetted parts required for HW systems operating over 250° F as well as for submersible meters.
Max. operating pressure for flow meters is 400 PSI.

Installation Hardware: All kits allow insertion/removal without system shutdown. Choose kit # from price book, or select below:					
A. Standard (w/1" valve, for new const.) B. Hot Tap (w/1.25" valve, for "wet tap") C. Stainless Steel (select A or B also) D. No Kit - provide height of valve assy.					
Wetted Metal Components Standard: Plated Brass Optional: 316 SS					
Signal Connections Standard: 10' cable & 1/2" conduit adapter Optional: Plenum cable w/ DIN connector					
Additional Signal Cable Standard: 10 ft. cable Optional: 25, 50 or 100 ft. additional cable					
Electronics Enclosure Standard: Weathertight enclosure Optional: Submersible enclosure *					
Optional Display Module (see catalog)					

FLOW METER INSTALLATION HARDWARE KITS



All ONICON insertion type flow meters can be installed and removed without system shutdown when installed through a 1" or larger full port ball valve. The terms: "Standard" and "Hot Tap" refer to the installation kit types only.

Standard Installation Kit: For new construction or scheduled shutdown. The valve is installed after the 1" hole is drilled in the pipe. Once the valve kit is installed, the flow meter can be installed or removed without system shutdown.

Hot Tap Installation Kit: For applications which require the access hole in the pipe to be drilled through the valve, using a wet tap drilling machine, with the hydronic system pressurized and operating.

PIPE MATERIAL	STANDARD KITS		HOT TAP KITS	
	KIT #	DESCRIPTION	KIT #	DESCRIPTION
Welded Carbon Steel / Black Iron (CS)	F-STD-INSTL1	Std. kit for 1.25" & larger welded steel pipe; includes bronze valve, fittings, weld-on CS branch outlet	F-HTAP-INSTL2	Hot tap kit for 1.25" & larger welded steel pipe; includes bronze valve, fittings, weld-on CS branch outlet
	F-STD-INSTL5	SS std. kit for 1.25" & larger welded steel pipe; includes 316SS valve, fittings, weld-on CS branch outlet	F-HTAP-INSTL6	SS hot tap kit for 1.25" & larger welded steel pipe; includes 316SS valve, fittings, weld-on CS branch outlet
Threaded Carbon Steel (CS)	F-STD-INSTL7	Std. kit for 1.25- 2.5" threaded pipe; includes bronze valve, fittings, 6" CS pipe nipple w/ branch outlet	F-HTAP-INSTL19	Hot tap kit for threaded steel pipe (1.5" and up); includes bronze valve, fittings and clamp-on saddle
	F-STD-INSTL8	SS std. kit for 1.25-2.5" threaded pipe; includes 316SS valve, fittings, 6" CS pipe nipple w/ branch outlet	F-HTAP-INSTL20	Hot tap kit for threaded steel pipe (1.5" and up); includes 316SS valve, fittings and clamp-on saddle
Copper tube	F-STD-INSTL3	Std. kit for 1" to 2" copper; includes bronze valve, fittings, copper tee	F-HTAP-INSTL21	Hot tap kit for 2" copper; includes bronze valve, fittings, special clamp-on saddle
	F-STD-INSTL4	Std. kit for 2.5" to 3" copper; includes bronze valve, fittings, copper tee	F-HTAP-INSTL22	Hot tap kit for 2.5 - 6" copper; includes bronze valve, fittings, special clamp-on SS saddle
	F-STD-INSTL9	Std. kit for 4" copper; includes bronze valve, fittings, copper tee		
Ductile Iron (cast iron)	F-STD-INSTL10	Std. kit for 3" to 6" ductile iron; includes bronze valve, fittings and clamp-on saddle	F-HTAP-INSTL23	Hot tap kit for 3" to 6" ductile iron; includes bronze valve, fittings and clamp-on saddle
	F-STD-INSTL11	Std. kit for 8" to 16" ductile iron; includes bronze valve, fittings and clamp-on saddle (brass/bronze)	F-HTAP-INSTL24	Hot tap kit for 8" to 16" ductile iron; includes bronze valve, fittings and clamp-on saddle
	F-STD-INSTL12	SS std. kit for 3" to 16" ductile iron; includes SS valve, fittings and clamp-on saddle	F-HTAP-INSTL25	SS hot tap kit for 3" to 6" ductile iron; includes SS valve, fittings and clamp-on saddle (all parts SS)
			F-HTAP-INSTL26	SS hot tap kit for 8" to 16" ductile iron; includes SS valve, fittings and clamp-on saddle (all parts SS)
PVC	F-STD-INSTL13	Std. kit for 2" to 6" PVC pipe. Includes bronze valve, fittings and clamp-on saddle	F-HTAP-INSTL27	Hot tap kit for 2.5" to 6" PVC pipe. Includes bronze valve, fittings and clamp-on saddle
	F-STD-INSTL14	Std. kit for 8" to 12" PVC pipe. Includes bronze valve, fittings and clamp-on saddle	F-HTAP-INSTL28	Hot tap kit for 8" to 12" PVC pipe. Includes bronze valve, fittings, and clamp-on saddle
	F-STD-INSTL15	SS/ PVC std. kit for 2" to 4" PVC pipe Includes SS valve, fittings and sch 80 PVC clamp-on saddle	F-HTAP-INSTL29	SS hot tap kit for 2" to 6" PVC pipe. Includes SS valve, fittings and clamp-on saddle (all SS parts)
	F-STD-INSTL16	SS/ PVC std. kit for 6" PVC pipe Includes SS valve, fittings and sch 80 PVC clamp-on saddle	F-HTAP-INSTL30	SS hot tap kit for 8" to 12" PVC pipe. Includes SS valve, fittings and clamp-on saddle (all SS parts)
	F-STD-INSTL17	SS std. kit for 8" to 12" PVC pipe. Includes SS valve, fittings and clamp-on saddle (all SS parts)		
Stainless steel	F-STD-INSTL18	SS std. kit for SS pipe. Includes 316SS valve, fittings and weld-on SS branch outlet (all SS parts)	F-HTAP-INSTL31	SS Hot tap kit for SS pipe. Includes SS valve, fittings and weld-on SS branch outlet (all SS parts)



Insertion Turbine Flow Meter Installation & Adjustment Guide

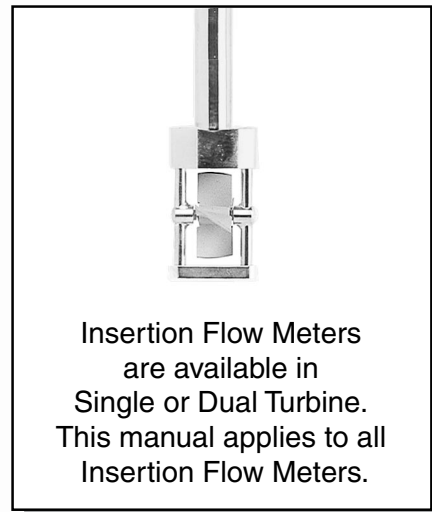

Insertion Flow Meters
are available in
Single or Dual Turbine.
This manual applies to all
Insertion Flow Meters.

For use with serial numbers
115692 and later

SAFETY INFORMATION

Throughout this manual some text appears in bold type. These statements contain information related to safety issues. Many installations of our meters will be in high pressure or high temperature systems and accidents with these systems can cause serious injury or death to those working on them or standing nearby. There is also the possibility of property damage.

Please pay extra attention to these areas of bold text.

The information in this manual has been carefully checked for accuracy. There is, however, the possibility of omission or error. In such an event, ONICON Incorporated does not assume liability for any damages resulting from the use of this manual.

SERVICE

If ONICON equipment requires servicing, we prefer to have it returned to the factory. In some cases you may want to service it yourself. Our technical staff will be happy to work with you in these cases; however, we request that you contact us before beginning to work on the equipment because we can provide helpful information which is not contained in this manual.

TABLE OF CONTENTS

1.0	INTRODUCTION	1
1.1	Purpose of This Guide.	1
1.2	A Typical Insertion Turbine Flow Meter	1
1.3	Standard Features and Specifications	2
1.4	Optional Hardware	2
1.5	Optional Features	3
1.6	Five Available Models.	3
1.7	Working Environment	4
1.8	Warranty and Serial Number.	4
2.0	UNPACKING	5
2.1	Checking That You Have Received Everything	5
3.0	INSTALLATION, REMOVAL, & ADJUSTMENT	7
3.1	Site Selection	7
3.2	Plumbing Installation	8
3.3	Insertion of the Meter	10
3.4	Removal of the Meter	11
3.5	Adjustment of the Meter	12
3.6	Electrical Connections.	12
4.0	START-UP COMMISSIONING FOR ONICON INSERTION TURBINE FLOW METERS	13
4.1	Helpful Hints for Start-up and Commissioning	13
4.2	Start-up and Commissioning for ONICON Insertion Flow Meters	14
4.3	Start-up and Commissioning Worksheet ONICON Insertion Turbine Flow Meters.	15
4.4	Troubleshooting Guide for ONICON Insertion Turbine Flow Meters	16
5.0	USER ADJUSTMENTS AND CALIBRATIONS	17
5.1	General Discussion	17
5.2	Analog Adjustment Procedure	18
	APPENDICES	
A	External Wiring Diagrams	
B	Internal Wiring Diagrams	
C	Turbine Assembly Detail Drawings	

SECTION 1.0: INTRODUCTION

We, at ONICON INCORPORATED, would like to thank you for purchasing our quality U.S. made Insertion Turbine Flow Meter. As our valued customer, our commitment to you is to provide fast reliable service and assistance, while continuing to offer you new products to meet your growing flow measurement needs.

1.1 PURPOSE OF THIS GUIDE

We have written this guide to provide the persons responsible for the installation, operation, and maintenance of your insertion flow meter with most of the specific equipment information they will need. This is NOT an electrical or plumbing trade manual.

PLEASE DO NOT PERMIT ANY PERSONS TO INSTALL, OPERATE, OR MAINTAIN THIS EQUIPMENT UNLESS THEY HAVE A COMPLETE KNOWLEDGE OF THEIR TRADE SKILLS AND ARE COMPETENT TO WORK ON HIGH VOLTAGE POWER WIRING OR HIGH PRESSURE HOT AND COLD WATER AND STEAM SYSTEMS, ACCORDING TO THEIR INDIVIDUAL TRADES. DEATH OR PERMANENT INJURY MAY RESULT FROM ACCIDENTS WITH THESE SYSTEMS.

This guide is the basic reference tool for everyone who purchases an ONICON Insertion Flow Meter regardless of which of the many options they may have selected. If you have not purchased all of the options, there will be references in this manual which are not applicable to your system.

1.2 A TYPICAL INSERTION TURBINE FLOW METER

ONICON'S F-1100 and F-1200 series Insertion Flow Meters are true turbine meters which measure the velocity of a flowing liquid by counting the frequency at which the blades of a rotating turbine pass a fixed electrode. Circuitry within the flow meter electronics enclosure then converts the rotational rate to digital and/or analog signals which are transmitted via a connecting cable to any of ONICON's display devices, BTU meters, or a data acquisition system. See the typical installation diagram on pages 10A-C.

A typical F-1100 or F-1200 series Insertion Flow Meter consists of the following components:

- **Electronics Enclosure**

The turbine rotation sensing circuit boards, along with the standard frequency output signal processing circuit boards, and most optional circuits such as ONICON's analog output signal processing board are housed in this die cast aluminum case.

- **Sensing Head Assembly**

This part of the meter is actually in the stream of liquid at the proper position to sense the average flow velocity. It consists of the turbines, bearings, shafts, electrodes, and the associated mechanical supporting structure.

- **Hot Tap Adapter**

The hot tap adapter provides the mechanical connection to the pipe through a coupling, welded fitting, or preferably, through a valve. The hot tap adapter and valve make removal easy.

If your flow meter was furnished with any additional items, they will be listed on the packing slip.

1.3 **STANDARD FEATURES AND SPECIFICATIONS**

- **Series F-1100**

- » Patented Non-magnetic Impedance Sensing System
- » Low Mass Non-metallic Turbine Rotor
- » Sapphire Radial and Axial Bearings
- » Tungsten Carbide Turbine Shaft
- » Hot Tap Adapter with Internal “O” Ring Seal
- » Pre-wired 10’ Signal Cable with Inline Connector
- » Calibrated Frequency Output
- » Die Cast Aluminum Case for Circuit Boards

- **Series F-1200**

This model has all of the features of the series F-1100 plus:

- » A Dual Turbine Sensing Head
- » Frequency Output Averaging Circuitry

1.4 **OPTIONAL HARDWARE**

- **Hot Tap Installation Kit**

This bronze full port valve, attached brass close nipple, and weld-on branch outlet fitting provide an easy way to remove the insertion meter from the pipe for routine service or inspection without interrupting the operation of the circulating liquid system. We **STRONGLY** recommend this option.

1.5 **OPTIONAL FEATURES**

- **316 Stainless Steel**

Wetted metal supporting structure is constructed from 316 stainless steel.

- **Conduit Connections**

Allows flexible conduit to be connected directly to the electronics enclosure. Includes 10' of $\frac{3}{8}$ " flexible conduit with connectors. The inline connector is not supplied with this configuration.

- **Weathertight Electronics Enclosure**

The standard electronics enclosure is designed for interior installations such as chiller plants. The weathertight enclosure should be used for exterior installations.

- **High Temperature Operation**

The standard ONICON Insertion Flow Meters will operate at a liquid temperature of up to 200° F (220° F peak); however, with a change of construction materials, the operating temperature can be increased to 280° F (300° F peak). Be sure to read the caution notices about high temperature operation in the installation section.

- **Additional Cable with Inline Connector**

Extra cable is frequently ordered, with the connector attached, to assist the installers by maintaining the factory wire colors.

- **Plenum Rated Cable with Inline Connector**

This option is offered to accommodate local building codes requiring plenum rated cable.

1.6 **FIVE AVAILABLE MODELS**

- **F-1100/F-1200: Frequency Output**

The standard frequency output signal is a calibrated non-isolated 0-15 V peak pulse frequency output and is included with ALL models of ONICON flow meters.

- **F-1110/F-1210: Analog Output**

These models provide factory calibrated 4-20 mA and 0-10 V analog output signals in addition to the standard calibrated frequency output.

- **F-1111/F-1211: Isolated Analog Output**

These models provide the same output signals as the F-1110/F-1210 models except that the analog signals are totally isolated from the common system ground.

- **F-1120/F-1220: Divided Output**

These models include a binary divider which can be used to reduce the standard output frequency to interface with monitoring equipment having a relatively slow scan rate. The output is a solid state photo-isolated switch (dry contact).

- **F-1130/F-1230: Scaled Output**

These models are similar to the F-1120/F-1220 except that they include a precision binary divider which allows the user to scale the output to one pulse per specific unit of volume, (i.e. one pulse per gallon, hundred gallons, liter, etc.). The output is a photo-isolated switch (dry contact).

1.7 **WORKING ENVIRONMENT**

We designed the F-1100 and F-1200 series Insertion Flow Meters for installation and use in typical industrial environments that are free of corrosive liquids and fumes, direct liquid exposure or heavy condensation, temperature extremes and vibrations.

The operating ambient air temperature range is -5° F to 160° F (-20° C to 70° C) with weathertight electronics enclosure.

The electrical power should be relatively clean, free of high frequency noise and large voltage transients, and protected from power surges and brown-outs.

1.8 **WARRANTY AND SERIAL NUMBER**

- **Warranty**

ONICON's complete warranty is included in Appendix D of this manual as a part of the "Conditions of Sale."

- **Serial Number**

The serial number of your Insertion Flow Meter is located on a label on the side of the circuit board case. This label also exhibits the model number. The serial number is a unique identifier that you should refer to, along with the model number, whenever you require assistance regarding your system.

SECTION 2.0: UNPACKING

Insertion Flow Meters are generally shipped in one package unless optional hardware or equipment is ordered. This package may contain up to two complete meters along with the optional valve assemblies. If any display equipment was ordered with the meters, the other equipment may be packed in a separate package. Please open all packages with caution to prevent damage to their contents. In the event that they are damaged when you receive them, notify the shipping company immediately and the ONICON Customer Service Department. All products are shipped insured.

2.1 CHECKING THAT YOU HAVE RECEIVED EVERYTHING

- **The Documentation**

Enclosed with each Insertion Flow Meter is a comprehensive documentation package which includes the following items:

- » A PACKING SLIP SHOWING ALL ITEMS SHIPPED OR BACK ORDERED
- » INSERTION FLOW METER INSTALLATION AND ADJUSTMENT GUIDE
- » THE FLOW METER CALIBRATION AND INSERTION DATA SHEETS

If any of these documents is missing, please notify the ONICON Customer Service Department.

- **The Flow Meter**

The flow meter is a rugged instrument and should arrive without any damage; however, when you remove it from the shipping carton, inspect it for physical damage such as broken turbine blades or a damaged stem.

- » Test the turbine(s) to see that they rotate freely when you blow on them parallel to their shafts.
- » Make sure that the threads on the hot tap adapter have not been damaged.
- » Inspect the long stem for bends or other damage. The stem forms the seal against liquid leakage as it slides through an 'O' ring inside the hot tap adapter. Deep scratches may cause leakage.

- » Confirm that any additional cable which you ordered has been included (10' is standard). Make certain that the serial/model number label, the wire connection/calibration data tag, and the **red safety tag** are attached to the meter. These tags should remain attached to the meters even after final installation.
- » The serial and model numbers on the wire connection/calibration data tag should match the numbers on the tag mounted directly on the flow meter. Be sure that the unit was calibrated to the correct pipe size and flow rate for your installation by comparing the wire connection/calibration data tag with your specifications.

- **Optional Equipment**

Any optional equipment, with the exception of the hot tap installation kit, may have been shipped in a second package. Open it and inspect for damage. The packing list reflects any other optional equipment ordered.

- **Discrepancies or Damage**

If you find discrepancies or damage, please notify the ONICON Customer Service Department as soon as possible.

SECTION 3.0: INSTALLATION, REMOVAL & ADJUSTMENT

*****CAUTION*****

Insertion Flow Meters will often be installed in pipes which are under high pressure. To prevent personal injury from moving parts of the meter, installation, adjustment, and removal should only be done by persons experienced with high pressure systems and related knowledge in the heating, cooling, and fluid metering fields. Refer to the installation drawings before performing any work on these meters.

ONICON will be happy to assist with technical recommendations and to provide guidance by telephone and/or mail. On-site field engineering, installation, and service is also available at additional cost.

Before beginning, clean the external surfaces of all pipes at the installation sites so that they are free of debris, foreign matter, solids, sticky liquids such as certain leak inhibitors, and chemically aggressive substances. Flush the entire system so that it is free of flux, solder, pipe and tube cuttings and any other free moving particles. Damage resulting from failure to maintain a clean system is not covered under the warranty.

3.1 SITE SELECTION

Careful attention to the site selection for the system components will help the installers with the initial installation, reduce start-up problems, and make future maintenance easier. For example, do not install the flow meter where it will be difficult for your personnel to perform the necessary periodic maintenance. When selecting a site for mounting the system components, you should consider the criteria under Section 1.7, WORKING ENVIRONMENT, as well as the following:

- » Install the flow meter in a straight length of pipe with no valves, tees, elbows, bends, or other such fittings, for a distance of at least 20 pipe diameters upstream and 10 pipe diameters downstream from the meter. This general rule applies only to single turbine insertion meters. Refer to pages 8A thru 8C for more information about installation location. If yours is a single turbine and there is no suitable location, contact ONICON's Sales Office to discuss upgrading to a dual turbine meter. This meter is more tolerant of conditions which cause swirl, turbulence, and flow profile distortions. Please make this decision before installing the single turbine meter so that we may be able to give you credit if you elect to upgrade to a dual turbine meter. Such returns may be subject to a restocking charge.

- » Choose a section of pipe that is well supported and free of harmonic motion and high or low frequency vibration.
- » The location must allow convenient access for easy removal for cleaning and preventive maintenance.
- » Place the flow meter so that it can be used with ONICON's standard hot tap adapter and a valve and nipple assembly, thereby allowing for easy removal for inspection or maintenance without draining or stopping the hydronic system.
- » A full 1" opening is required to clear the turbine assembly. Make sure that your valves and fittings are full port and at least 1" in actual internal diameter.

3.2 **PLUMBING INSTALLATION**

All plumbing installations should be done only in pipes which have readily accessible shut-off valves so that the flow may be turned off in case of an emergency.

Once you choose the installation site for your flow meter, clean the mounting surface so that it is free of insulation, corrosion, and other debris. Next, relieve all pressure within the fluid system and reduce the fluid level to the height where no liquid will escape when you drill the installation holes in the pipe.

To take advantage of ONICON Flow Meters' built-in Hot Tap feature, the flow meter must be installed through an isolation valve.

The drawings on pages 10A and 10B show installations using ONICON's *Standard Installation Hardware* kit in a drained, non-pressurized system. The access hole is drilled (1" minimum) prior to installation of the 1" NPT branch outlet, close nipple and full port ball valve. Once the isolation valve is installed, the piping system can be flushed and pressurized. The flow meter can now be inserted or removed by hand without having to drain the system again. Please refer to page 10 for important safety instructions.

ONICON's *Hot Tap Installation Hardware* kit offers an alternative installation when it is not practical to drain or relieve the pressure in the system. The drawings on pages 10C and 10D show the Hot Tap installation configuration. In this case, a 1¼" branch outlet, close nipple and 1¼" full port ball valve are installed first. Then, a hot tap drilling apparatus can be used to drill a 1" diameter hole through the valve, without shutting down or draining the pipe.

You can also attach the flow meter to the pipe with a saddle. The meter requires relatively little structural support and any saddle suitable for the system operating pressure should be adequate. Hot tap drilling attachments also work well with clamp-on saddles.

When installations are made in small pipe sizes, a tee may be available; however, the inside diameter of most tees is larger than that of the pipe and a tee also creates more turbulence than a small drilled hole. If you will be mounting the flow meter in a tee and our factory was not aware of that at the time of calibration, return the meter for recalibration in a tee.

Consider the following:

- » The access hole into the pipe should be as small as possible to minimize turbulence (1" diameter minimum.)
- » Always use a valve assembly as shown on pages 10A & 10B. Turbine meters require periodic maintenance and you should be able to remove the meter when necessary without shutting down your system.
- » If you select a 1" valve, it must be a full port valve. A standard 1" valve will usually have an undersized inside diameter.
- » Install the flow meter in an area which is easily accessible for future service.
- » Try to limit the overall height from the pipe's outside diameter to the top of the valve to 5½" - 6". ONICON calculates the stem length of the flow meter based on pipe size and this nominal height. If your installation requires a higher fitting assembly and the dimension was not specified on the order form, please contact the factory before installation. This way ONICON can offer you credit for your meter if you decide to exchange it for one with a longer stem. Such a return may be subject to a restocking charge.

After fitting the necessary plumbing hardware, flush the entire system so that it is free of flux, solder, and slag. Prepare to install the flow meter by loosening the clamping nut and withdrawing the turbine assembly entirely into the hot tap adapter. Next, thread the adapter into the ball valve using a paste type thread sealant. Do not use teflon tape because torn strands of the tape may wind around the turbine, slowing down or even stopping the turbine rotor.

When you are ready to refill the system, make sure that all lines are filled with water before inserting the turbine into the stream. If the lines are not filled, air may interrupt the flowing stream and damage the turbine assembly. A greater danger is that if this is a hot water system, some water may flash into steam and exceed the high temperature limit for the turbine and its mechanical assembly. The assembly could fail to hold the pressure and allow steam and hot water to escape causing serious injury or death.

Check the installation for leaks by slightly opening the ball valve under the hot tap adapter. An “O” ring in the adapter seals the meter’s stem against leakage. If there are any leaks around the clamping nut or stem, **DO NOT ATTEMPT TO STOP THE LEAKAGE BY OVERTIGHTENING THE CLAMPING NUT. Damage to this nut or the clamping ring under the nut may prevent the assembly from properly holding the meter in the pipe.** The clamping nut is not part of the sealing mechanism. Any leaks in this area indicate that the “O” ring is not sealing properly and you must contact the factory for assistance.

3.3 **INSERTION OF THE METER**

Begin by calculating the effort that will be required to hold the meter. Establish adequate footing for this task, taking extra caution when working from a ladder or platform. Use the following formula:

$$E=0.11 \times P \quad \text{Where:} \quad \begin{array}{l} E=\text{effort in pounds} \\ P=\text{system pressure in pounds per square inch} \end{array}$$

Example: In a 300 PSI system, 33 pounds of effort is required to push the meter into the pipe.

- **Meter with a factory supplied depth gage: (Refer to the following diagram.)**
 1. Pierce insulation with gage until the tip touches the pipe.
 2. Open valve completely, loosen the lock nut, and insert the meter until the bottom of the electronics case touches the eye of the depth gage.
 3. Align the arrow on the meter with the flow direction and tighten the lock nut.
- **Meter without a gage: (Refer to pages 10A & 10B for insertion information)**

Position the electronics enclosure parallel to the pipe in the direction relative to the flow, as shown on the label and on pages 10A & 10B. This will position the turbine with its axis in line with the flow and in the same direction as it was calibrated at the factory.

Do not release the flow meter until you have tightened the position clamping nut enough to hold the flow meter in the desired location. This will require less torque than you might think, so be careful not to over-tighten it and risk damaging the adapter, nut, or stem.

Place several turns of electrical tape around the stem just above the clamping nut so that if the meter is removed at a later time, it can be easily replaced in the same position.

NOTE: For installations with limited straight run of pipe (less than the recommended distances shown on pages 8A, 8B and 8C), adjustments in insertion depth may be desirable to compensate for velocity flow profile variations. Please contact the factory for information on velocity flow profiling for determining the average velocity location in undeveloped flow locations.

3.4 REMOVAL OF THE METER

Caution - Remember, the meter may be under high pressure, and while removal of the meter is basically the reverse of the insertion procedure detailed above, care must be taken to ensure that the meter is supported against the pipe pressure before the position clamping nut is loosened. Failure to do this will allow the pressure to suddenly and rapidly force the meter from the pipe and someone could be seriously injured if struck by the meter.

Prior to removal of the meter, make sure that you are standing on a secure platform and have both hands available to manipulate the flow meter.

First support the flow meter against the pipe pressure by holding the circuit board enclosure firmly by hand BEFORE loosening the position clamping nut. The effort which will be required is the same as that required for insertion of the meter and should be calculated according to the formula in the prior section covering insertion of the meter. This effort will be 0.11 times the pipe pressure. **If your footing is not secure, or if you are unsure of your ability to hold the meter for any reason, DO NOT loosen the clamping nut.**

Then **SLOWLY** loosen the position clamping nut and **carefully and slowly** allow the pressure to force the meter out of the pipe. This is not at all difficult, but you must not let go of the meter until it is fully withdrawn into the hot tap adapter as shown in the inset drawings on pages 10A & 10B. After the meter is completely withdrawn, you may close the isolation ball valve.

The main cause of damage to the meters comes from persons accidentally closing the valve on the turbine assembly. To avoid this, gently rotate the meter by twisting the circuit board enclosure back and forth (twist the stem, do not bend it) while you slowly close the valve. If the valve touches any part of the meter, you will feel it as you are twisting the meter. If the valve touches anything, it means the meter is not fully withdrawn. Usually a gentle twisting motion while withdrawing the meter will clear any obstructions and permit the meter to withdraw completely.

After the valve is completely closed, you can safely unscrew the hot tap adapter from the valve. There will be very little water in the hot tap adapter; however, a small bucket or pan should be held under the valve to catch any spilled water.

NOTE: Flow meters prior to S/N 102860 utilized a Delrin (plastic) compression ring in the position clamping nut which tended to deform and not release the flow meter completely when the position clamping nut was loosened. This resulted in the installer possibly having to assist the meter out of the pipe by pulling on the electronics enclosure. For flow meters S/N 102860 and higher, the position clamping nut was redesigned utilizing a slotted brass collet assembly which releases quickly and completely allowing the pressure of the line to

push the meter out of the pipe.

3.5 ADJUSTMENT OF THE METER

CAUTION - If adjustment of the meter position is required, the same procedure must be followed as if the meter was being removed. Please carefully read the section above on removal of the meter. Remember, the meter may be under high pressure and failure to follow the procedure may result in injury or death.

Once the meter has been moved to its new position, tighten the position clamping nut and place several turns of electrical tape around the stem just above the clamping nut so that at a later time, when the meter is removed for service, it can be easily replaced in the same position.

3.6 ELECTRICAL CONNECTIONS

Most insertion flow meters are furnished with an inline cable connector which makes it easy to remove the meter for cleaning or service. If your meter was furnished with the conduit option, it will not have a connector. Refer to page 12A for installation details. Make your electrical connections to the 10' cable, which is supplied by ONICON and is pre-wired to the connector, or circuit board when the conduit option is furnished.

Please do not attempt to make any connections inside the electronics case, or to remove factory installed connection fittings. Damage resulting from these actions will not be covered under warranty.

Caution - the most common cause of electronic failure is incorrect connection. If you will be adding any additional cable, please record any substitution of wire colors. If additional cable is purchased from ONICON, the color code can be maintained. However, cable from other sources will most likely have a different set of colors. Please refer to Appendix A for wiring diagrams and factory color codes.

Only qualified service personnel should make connections between the Insertion Flow Meter and the user's external equipment. Any misapplication of power and/or ground can result in improper operation of the unit or damage to the Insertion Flow Meter, the flow meter circuitry, and to any externally connected equipment.

SECTION 4.0: START-UP COMMISSIONING FOR ONICON INSERTION TURBINE FLOW METERS

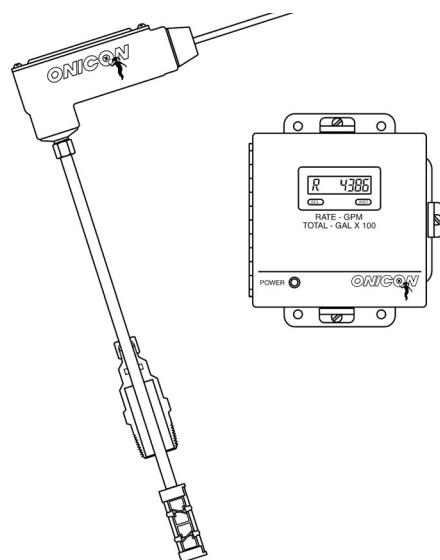

4.1 HELPFUL HINTS FOR START-UP AND COMMISSIONING

A step-by-step procedure and companion worksheet are located on the next two pages. Please read all installation instructions carefully before proceeding with installation, start-up and commissioning.

Please read these helpful hints before proceeding with the start-up and commissioning procedure on the next page.

1. ONICON Flow Meters are individually calibrated for a particular application. Be sure to verify the pipe size and location.
2. The electronic sensing system will not work in air. Blowing on the turbine(s) will not produce a signal. You can test the meter by holding the turbines under a faucet or carefully moving it back and forth in a bucket of water.
3. When measuring analog output signals, remember that currents (mA) must be measured in series, while voltages are measured in parallel. If the 4-20 mA signal is already connected to a control system, you must break the connection and measure the signal in series.
4. When measuring frequency outputs in hertz, take your multimeter out of “autorange mode” and manually set range for a voltage level above 15 VDC. This will prevent false readings when no turbine signal is present.
5. All wiring connections should be made at the end of the factory cable. Do not attempt to remove the factory installed cable or change the orientation of the electronics enclosure.
6. Never connect power to analog or frequency output signal wires. ONICON flow meters are not “loop powered” devices.

4.2 START-UP AND COMMISSIONING FOR ONICON INSERTION TURBINE FLOW METERS

Please read all installation carefully before proceeding. Wiring diagrams are located in the appendix. A worksheet for checking off the following steps and recording measured values is located on the following page.

1.	Confirm meter location and adequate straight pipe run to achieve desired results	Is the meter located in the correct location as required by the plans? Compare actual straight pipe upstream and downstream of the meter location to recommended distances identified in the installation manual. Note that the manual is very conservative, assuming worst-case pipe obstructions; contact ONICON's technical support department to discuss specifics of your application. If straight pipe run is very short, consult factory PRIOR to installing a single turbine meter to discuss possibility of upgrade to a dual turbine meter.
2.	Confirm Pipe Size	Confirm that the meter is tagged for the pipe size it is installed in. When in doubt measure the circumference of the pipe. Pipe O.D. = (circumference / 3.14) - (insulation thickness x 2)
3.	Confirm insertion depth and orientation	Each flow meter comes with an attached insertion gage and instruction tag. Ensure that meter is inserted to the correct depth and that the electronics enclosure is parallel with the pipe, with the arrow in the direction of flow.
4.	Confirm control system programming	Confirm that the control system input point is properly configured for the analog range (or binary scale factor) identified on the flow meter calibration tag & certificate.
5.	Confirm connection to correct ONICON display or BTU Meter (if ordered)	Confirm that the flow meter serial number matches the ONICON display or BTU meter serial number (when ordered together)
6.	Verify wiring before connecting power	Prior to connecting the power, verify that wiring is correct as shown in this manual and/or additional wiring diagram provided with ONICON display or BTU meter. If in doubt, call factory for assistance before proceeding further.
7.	Confirm correct supply voltage	Verify that 24 (+/- 4) V is available. Serial Numbers 115692 and later can accept 24 V DC or AC, but earlier meters required 24 VDC. Note: ONICON display module or BTU Meter provides 24 VDC to the flow meter. ONICON display modules and BTU meters are typically powered by 120 VAC, however, low voltage versions are also available.
8.	Connect power	Wait approximately 45 seconds after power-on before proceeding further.
The following steps require flow in the pipe. Flow signal readings should be taken while holding the flow rate constant if possible, otherwise, take the various output readings as quickly as possible.		
9.	Measure and record frequency output(s):	The average frequency output signal is a 0-15 VDC pulsed output ranging up to 200 Hz and must be measured with a frequency counter or oscilloscope. Measure DC Frequency (Hz) from GREEN(+) to BLACK(-). Also measure DC volts on same wires. 5 to 7 VDC is normal for a spinning turbine, 0 or 14+ VDC indicates a stopped turbine. (1 to 4 VDC could indicate a problem) $\text{GPM} = \frac{\text{Frequency in Hz} \times 60}{\text{Meter Factor in ppg}}$ (refer to calibration tag for meter factor) For Dual Turbine models, also measure and record the top and bottom turbine signals TOP: WHITE (+) to BLACK (-) BOTTOM: ORANGE (+) to BLACK (-)
10.	Measure and record analog or binary outputs Current Output: Voltage Output: Divided Output: Scaled Output:	Refer to flow meter wiring diagram for wire colors for the various outputs available, based on your particular flow meter model. Use the following formulas to calculate flow rate from measured analog signals: $\text{GPM} = \frac{(\text{measured current in mA} - 4)}{16} \times \text{Full Scale Analog Flow Rate}$ $\text{GPM} = \frac{\text{measured DC volts}}{10} \times \text{Full Scale Analog Flow Rate}$ Same calculations step 9, except use divided meter factor (measure and record frequency) Each contact closure = unit volume identified as Scale Factor (measure and record time interval between contact closures)
11.	Compare various output signals to each other and to the flow rate displayed by the control system	The top and bottom turbine frequencies (dual) should be within about 20% of each other and their average should equal the average frequency output. Compare the flow rates calculated in STEPS 9 and 10 to each other and to the flow rate indicated by the control system. Refer to troubleshooting guide when readings are inconsistent.

4.3 START-UP AND COMMISSIONING WORKSHEET ONICON INSERTION TURBINE FLOW METERS

Please read all installation instructions carefully prior to proceeding with these steps. Wiring diagrams are located in the appendix. Use the following worksheet for checking off the commissioning steps and recording measured values:

STEP	TEST / MEASUREMENT	S/N:_____	S/N:_____	S/N:_____	S/N:_____
1.	Meter location	<input type="checkbox"/>	<input type="checkbox"/>	<input type="checkbox"/>	<input type="checkbox"/>
2.	Confirm pipe size	<input type="checkbox"/> _____	<input type="checkbox"/> _____	<input type="checkbox"/> _____	<input type="checkbox"/> _____
3.	Insertion depth and orientation	<input type="checkbox"/>	<input type="checkbox"/>	<input type="checkbox"/>	<input type="checkbox"/>
4.	Control system programming	<input type="checkbox"/>	<input type="checkbox"/>	<input type="checkbox"/>	<input type="checkbox"/>
5.	Match display or BTU meter serial # (if ordered)	<input type="checkbox"/> _____	<input type="checkbox"/> _____	<input type="checkbox"/> _____	<input type="checkbox"/> _____
6.	Signal connections verified	<input type="checkbox"/>	<input type="checkbox"/>	<input type="checkbox"/>	<input type="checkbox"/>
7.	Supply voltage verified	<input type="checkbox"/> _____	<input type="checkbox"/> _____	<input type="checkbox"/> _____	<input type="checkbox"/> _____
8.	Connect power	<input type="checkbox"/>	<input type="checkbox"/>	<input type="checkbox"/>	<input type="checkbox"/>
<p>The following steps require flow in the pipe. Flow signal readings should be taken while holding the flow rate constant if possible, otherwise, take the various output readings as quickly as possible.</p>					
9.	Frequency output(s): Avg = green, Top = white Bottom = orange				
	Avg Freq. (HZ): _____ Hz	_____ Hz	_____ Hz	_____ Hz	_____ Hz
	Avg Freq. (VDC): _____ VDC	_____ VDC	_____ VDC	_____ VDC	_____ VDC
	Top Turbine (HZ) _____ Hz	_____ Hz	_____ Hz	_____ Hz	_____ Hz
	Top Turbine (VDC) _____ VDC	_____ VDC	_____ VDC	_____ VDC	_____ VDC
	Bottom Turbine (HZ): _____ Hz	_____ Hz	_____ Hz	_____ Hz	_____ Hz
	Bottom Turbine (VDC): _____ VDC	_____ VDC	_____ VDC	_____ VDC	_____ VDC
	Calculated Flow Rate: _____ GPM	_____ GPM	_____ GPM	_____ GPM	_____ GPM
10.	Analog or binary outputs				
	4 - 20 mA signal: _____ mA	_____ mA	_____ mA	_____ mA	_____ mA
	0 - 10 V signal: _____ VDC	_____ VDC	_____ VDC	_____ VDC	_____ VDC
	Scaled output interval or divided output frequency	_____	_____	_____	_____
	Calculated Flow Rate: _____ GPM	_____ GPM	_____ GPM	_____ GPM	_____ GPM
11.	Flow rate displayed by control system	_____ GPM	_____ GPM	_____ GPM	_____ GPM

4.4 TROUBLESHOOTING GUIDE FOR ONICON INSERTION TURBINE FLOW METERS

NOTE: Also refer to the START-UP and COMMISSIONING GUIDE located on the preceding pages.

REPORTED PROBLEM:	POSSIBLE SOLUTIONS
No Signal	Verify that the meter is correctly inserted into the pipe. Verify that the electronics enclosure is parallel with the pipe. Verify 24 V supply voltage. Verify correct wiring to control system (see wiring diagram) Check turbine(s) for debris.
Reading is too high or too low	Verify pipe size. Contact factory if pipe size is different from calibration tag. Verify that meter is inserted correctly into the pipe. Verify that the electronics enclosure is parallel with the pipe. Verify correct wiring to control system (see wiring diagram). Confirm that output signals are consistent (frequency vs. analog, etc). Confirm that control system is programmed for correct flow range or scale factor. Check turbine(s) for debris.
Analog signal seems high or low and does not correspond to frequency output	Check for ground loop or offset voltage: Disconnect analog signal input to control system and measure analog outputs directly from the flow meter. Re-connect signal input to control system and measure the analog signals again. Any difference between these readings indicates a potential ground loop or offset voltage. Please contact ONICON for further assistance.
Control system displays flow rate, but no flow rate indication on local display module or BTU Meter	Verify that all wires from flow meter were connected to the display module or BTU Meter. The frequency output wire (green) must be connected for any ONICON Display or BTU Meter.

For technical assistance, contact ONICON Incorporated at (727) 447-6140.

SECTION 5.0: ANALOG ADJUSTMENT PROCEDURE

Our electronic circuits are designed and tested to ensure long life with minimal drift; therefore, you should not expect to make regular field adjustments or calibrations. However, it will be necessary for you to rescale the analog output under the following conditions:

- The turbine was replaced with a new one having a significantly different meter factor.
- You wish to change the flow rate represented by the analog output.
- An analog output card was added in the field.
- An analog output meter is being moved to a different size pipe.

ONICON will do all of these recalibrations at low cost and with a one or two day turn-around. However, we have included this section for those instances where you cannot return the meter or simply want to do the work yourself. We will be happy to work through the procedure with you on the phone, if you desire.

While these adjustments are not complicated, they are crucial for accurate performance of the flow meter. Therefore, any adjustments should be made only by qualified personnel having an understanding of flow equations and experience with control systems.

5.1 GENERAL DISCUSSION

ONICON Insertion Flow Meters contain circuitry which measures the velocity of a flowing stream of water, or water based liquid, by sensing the rotational rate of a freely rotating axial turbine which is immersed in the flowing stream. As each turbine blade passes a fixed electrode, an electronic pulse is produced by the circuitry. In the case of single turbine meters, the pulse rate is then calibrated in terms of the number of pulses per gallon in whatever size pipe the user has selected. This number is called the METER FACTOR. For example an Insertion Flow Meter might have a meter factor of 31.3 PPG (Pulses Per Gallon) in 3" pipe. This is the calibrated frequency output signal.

Dual turbine meters are basically the same except that the pulse rates from the upper and lower turbines are electronically averaged and the calibration is done using this average output signal.

This frequency output signal can be used directly by many data acquisition systems. Other systems require an analog representation of flow rate. For these systems the frequency output signal is processed by the optional analog output card and another calibration is then done on the 4-20 mA and 0-10 V analog output signal.

5.2 ANALOG ADJUSTMENT PROCEDURE

This procedure adjusts both 4-20 mA & 0-10 V output signals. It is limited to meters with serial numbers 115692 and higher. Lower serial numbers cannot be rescaled in the field.

5.21 Equipment Required

- Voltmeter
- Pulse Generator
- 24 V Power Supply

5.22 Procedure

- 1) Determine the input frequency required to simulate the desired maximum flow rate using the equation below.

Where:

F = Input Frequency (Hz)

R = Maximum Flow Rate (GPM)

MF = Meter Factor* (Pulses Per Gallon)

$$F = \frac{R \times MF}{60}$$

*The meter factor is written on a calibration tag attached to each meter and is also recorded on the calibration data sheet. Please contact the factory if you cannot locate the meter factor.

- 2) Remove the flow meter from the pipe and make sure the electrode and the surrounding area are dry.
- 3) Choose the input frequency range (Hz) from the table on the next page and set the appropriate range selection switch. Some meters may have jumpers instead of switches. Refer to Appendix B for the internal wiring diagram of your model.
- 4) Connect the pulse generator output lead to the test signal input lead on the analog card, and connect the pulse generator ground lead to the black ground wire in the flow meter cable. Set the output to a 15 V P-P square wave at the frequency determined in step #1.
- 5) Set the DC voltmeter to the 0-10 V scale and connect the (+) lead to the brown wire in the flow meter cable. Connect the (-) lead from the voltmeter to the black ground wire in the flow meter cable.

- 6) Connect the red and black wires in the flow meter cable to the (+) and (-) terminals of the 24 V power supply respectively. Apply power.
- 7) Adjust the span potentiometer on the analog card to produce a 10 V reading on the voltmeter.

NOTE:

The selection switch frequency ranges in the table are a starting point, and since they vary with electronic component tolerance, it may be necessary to change the switch position once rescaling is started. If the range of adjustment of the span potentiometer is not sufficient to produce the desired 10 VDC, change the switch position as follows:

VOLTAGE READING TOO HIGH: Choose the next lower switch position.

VOLTAGE READING TOO LOW: Choose the next higher switch position.

- 8) The flow meter is now rescaled. Disconnect all equipment, replace the cover and reinstall the flow meter.

Analog Range Switch Settings		
INPUT FREQUENCY (Hz) AT MAXIMUM FLOW RATE		SWITCH POSITION SINGLE / DUAL TURBINE
Over 248	Hz	1
124-248	Hz	2
62-123	Hz	3
31-61	Hz	4
15-30	Hz	5
Under 15	Hz	6

NOTES:

APPENDIX A

External Wiring Diagrams

FLOW METER WIRING INFORMATION

User Connections for Models with Frequency Output
 Models: F-1100, F-1200, FB-1200 & F-1300

				Wiring Information		
F-1100 Single Turbine	F-1300 Inline	F-1200 Dual Turbine	FB-1200 Bi-Directional	WIRE COLOR CODE		NOTES
√	√	√	√	RED*	(+) 24 ± 4 V AC/DC supply voltage	Connect to power supply positive
√	√	√	√	BLACK	(-) Common ground (Common with pipe ground)	Connect to power supply negative
√	√	√	√	GREEN	(+) Frequency output signal: 0-15 V peak pulse	Output frequency is typically below 200 Hz, but can be up to 300 Hz
			√	GRAY	Dry contact directional output - indicates flow direction	Contact closed when flow is in direction of arrow on meter
			√	VIOLET		
				DIAGNOSTIC SIGNALS		
		√	√	ORANGE	Bottom turbine frequency	These signals are for diagnostic purposes - connect to local display or BTU meter
		√	√	WHITE	Top turbine frequency	

F-1100 / F-1200 / F-1300 Wiring Diagram

Flow Meter Connections to ONICON Display or BTU Meter

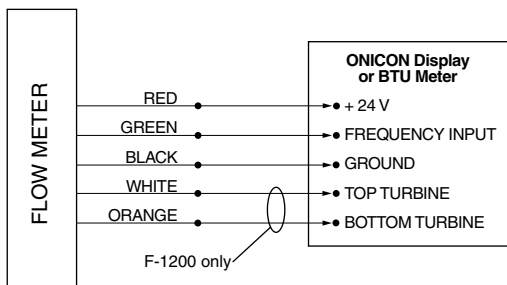

FB-1200 Wiring Diagram

Connections to ONICON Display or BTU Meter

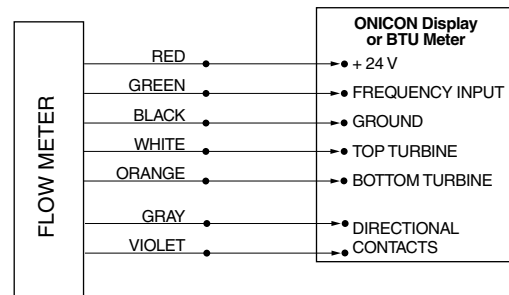

- NOTES: * 1. Serial Numbers 115691 and earlier require 24 VDC. Serial Numbers 115692 and higher can accept 24 V AC/DC.
 2. Black wire is common with the pipe (typically earth ground).
 3. For ONICON display module or BTU meter, connect all wires provided. Refer to wiring diagram provided with display or BTU meter.

FLOW METER WIRING INFORMATION

User Connections for Models with Non-Isolated Analog Outputs

Models: F-1110, F-1210, FB-1210 & F-1310

				Wiring Information		
F-1110 Single Turbine	F-1310 Inline	F-1210 Dual Turbine	FB-1210 Bi-Directional	WIRE COLOR CODE		NOTES
√	√	√	√	RED*	(+) 24 ± 4 V AC/DC supply voltage	Connect to power supply positive
√	√	√	√	BLACK	(-) Common ground (Common with pipe ground)	Connect to power supply negative & analog input ground
√	√	√	√	GREEN	(+) Frequency output signal: 0-15 V peak pulse	Required when meter is connected to local display or BTU meter
√	√	√	√	BLUE	(+) Analog signal: 4-20 mA (non-isolated)	Both signals may be used independently (unless 0-5 V output is ordered)
√	√	√	√	BROWN	(+) Analog signal: 0-10 V (non-isolated) (Can also be ordered as 0-5 V)	
			√	GRAY	Dry contact directional output - indicates flow direction	Contact closed when flow is in direction of arrow on meter
			√	VIOLET		
DIAGNOSTIC SIGNALS						
		√	√	ORANGE	Bottom turbine frequency	These signals are for diagnostic purposes - connect to local display or BTU meter
		√	√	WHITE	Top turbine frequency	

F-1110 / F-1210 / F-1310 Wiring Diagram

Connections to a Control System (No Display or BTU Meter)

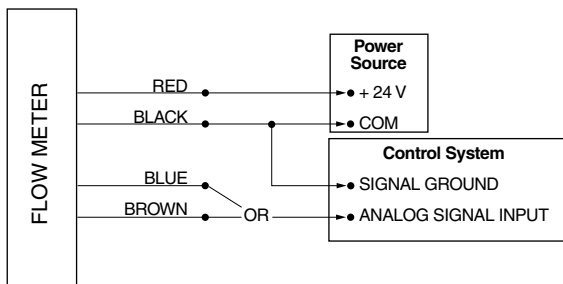

FB-1210 Wiring Diagram

Connections to a Control System (No Display or BTU Meter)

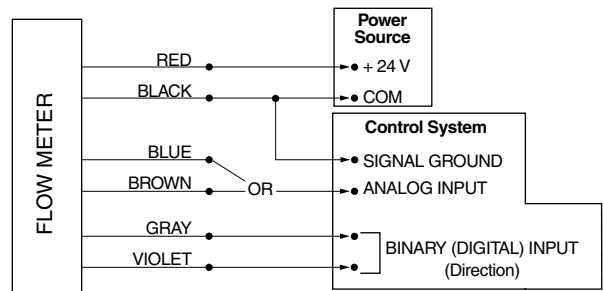

- NOTES: * 1. Serial Numbers 115691 and earlier require 24 VDC. Serial Numbers 115692 and higher can accept 24 V AC/DC.
2. Black wire is common with the pipe (typically earth ground).
 3. For ONICON display module or BTU meter, connect all wires provided. Refer to wiring diagram provided with display or BTU meter.
 4. This is NOT a "loop-powered" instrument. DO NOT connect power to any of the signal output wires (blue, brown, green, orange or white)

FLOW METER WIRING INFORMATION

User Connections for Models with Isolated Analog Outputs

Models: F-1111, F-1211, FB-1211 & F-1311

				Wiring Information		
F-1111 Single Turbine	F-1311 Inline	F-1211 Dual Turbine	FB-1211 Bi-Directional	WIRE COLOR CODE		NOTES
√	√	√	√	RED*	(+) 24 ± 4 V AC/DC supply voltage	Connect to power supply positive
√	√	√	√	BLACK	(-) Common ground (Common with pipe ground)	Connect to power supply negative
√	√	√	√	GREEN	(+) Frequency output signal: 0-15 V peak pulse	Required when meter is connected to local display or BTU meter
√	√	√	√	BLUE	(+) Analog signal: 4-20 mA (isolated)	Both signals may be used independently (unless 0-5 V output is ordered)
√	√	√	√	BROWN	(+) Analog signal: 0-10 V (isolated) (Can also be ordered as 0-5 V)	
√	√	√	√	YELLOW	(-) Isolated ground	Use for analog signals only
			√	GRAY	Dry contact directional output - indicates flow direction	Contact closed when flow is in direction of arrow on meter
			√	VIOLET		
DIAGNOSTIC SIGNALS						
		√	√	ORANGE	Bottom turbine frequency	These signals are for diagnostic purposes - connect to local display or BTU meter
		√	√	WHITE	Top turbine frequency	

F-1111 / F-1211 / F-1311 Wiring Diagram

Connections to a Control System (No Display or BTU Meter)

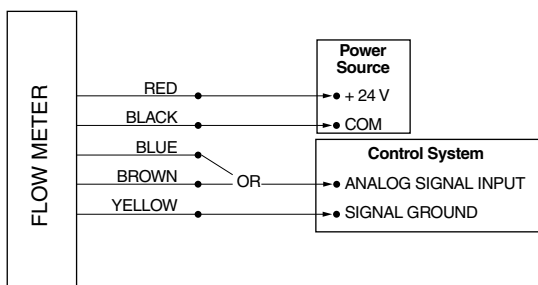

FB-1211 Wiring Diagram

Connections to a Control System (No Display or BTU Meter)

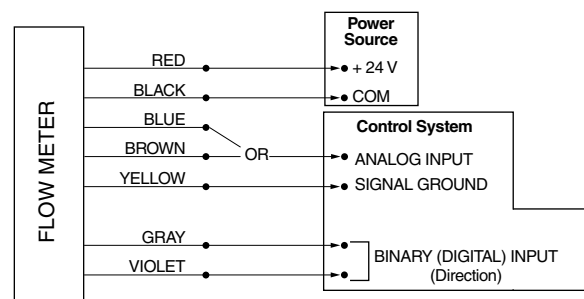

- NOTES: * 1. Serial Numbers 115691 and earlier require 24 VDC. Serial Numbers 115692 and higher can accept 24 V AC/DC.
2. Black wire is common with the pipe (typically earth ground).
3. For ONICON display module or BTU meter, connect all wires provided. Refer to wiring diagram provided with display or BTU meter.
4. This is NOT a "loop-powered" instrument. DO NOT connect power to any of the signal output wires (blue, brown, green, orange or white)

FLOW METER WIRING INFORMATION

User Connections for Models with Divided Output

Models: F-1120, F-1220, FB-1220 & F-1320

				Wiring Information		
F-1120 Single Turbine	F-1320 Inline	F-1220 Dual Turbine	FB-1220 Bi-Directional	WIRE COLOR CODE		NOTES
✓	✓	✓	✓	RED*	(+) 24 ± 4 V AC/DC supply voltage	Connect to power supply positive
✓	✓	✓	✓	BLACK	(-) Common ground (Common with pipe ground)	Connect to power supply negative
✓	✓	✓	✓	GREEN	(+) Frequency output signal: 0-15 V peak pulse	Required when meter is connected to local display or BTU meter
✓	✓	✓	✓	BLUE	Dry contact divided output - indicates flow rate	Output can be divided by any binary number up to 4096 to meet frequency limitations of control system
✓	✓	✓	✓	BROWN		
			✓	GRAY	Dry contact directional output - indicates flow direction	Contact closed when flow is in direction of arrow on meter
			✓	VIOLET		
				DIAGNOSTIC SIGNALS		
		✓	✓	ORANGE	Bottom turbine frequency	These signals are for diagnostic purposes - connect to local display or BTU meter
		✓	✓	WHITE	Top turbine frequency	

F-1120 / F-1220 / F-1320 Wiring Diagram

Connections to a Control System (No Display or BTU Meter)

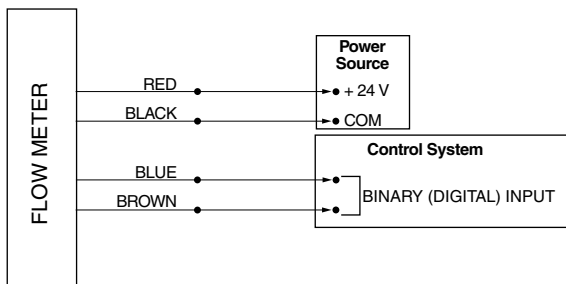

FB-1220 Wiring Diagram

Connections to a Control System (No Display or BTU Meter)

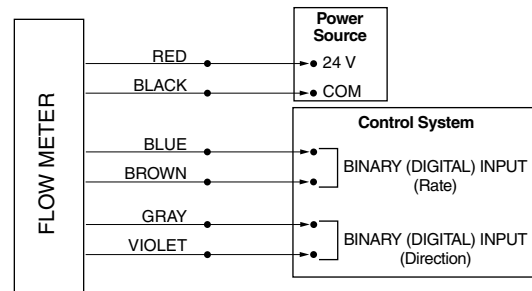

- NOTES: * 1. Serial Numbers 115691 and earlier require 24 VDC. Serial Numbers 115692 and higher can accept 24 V AC/DC.
2. Black wire is common with the pipe (typically earth ground).
3. For ONICON display module or BTU meter, connect all wires provided. Refer to wiring diagram provided with display or BTU meter.

FLOW METER WIRING INFORMATION

User Connections for Models with Scaled Output

Models: F-1130, F-1230, FB-1230 & F-1330

				Wiring Information		
F-1130 Single Turbine	F-1330 Inline	F-1230 Dual Turbine	FB-1230 Bi-Directional	WIRE COLOR CODE		NOTES
√	√	√	√	RED*	(+) 24 ± 4 V AC/DC supply voltage	Connect to power supply positive
√	√	√	√	BLACK	(-) Common ground (Common with pipe ground)	Connect to power supply negative
√	√	√	√	GREEN	(+) Frequency output signal: 0-15 V peak pulse	Required when meter is connected to local display or BTU meter
√	√	√	√	BLUE	Dry contact scaled output	Scaled to provide one pulse per volumetric unit Examples: 1 pulse per 10 gal. 1 pulse per 100 gal.
√	√	√	√	BROWN		
			√	GRAY	Dry contact directional output - indicates flow direction	Contact closed when flow is in direction of arrow on meter
			√	VIOLET		
DIAGNOSTIC SIGNALS						
		√	√	ORANGE	Bottom turbine frequency	These signals are for diagnostic purposes - connect to local display or BTU meter
		√	√	WHITE	Top turbine frequency	

F-1130 / F-1230 / F-1330 Wiring Diagram

Connections to a Control System (No Display or BTU Meter)

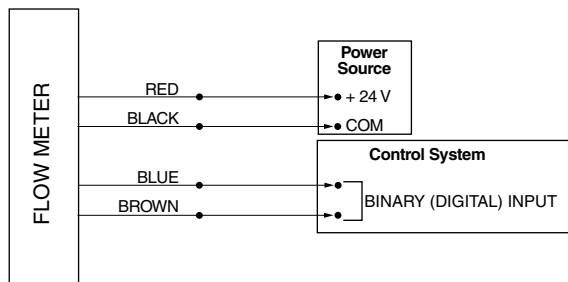

FB-1230 Wiring Diagram

Connections to a Control System (No Display or BTU Meter)

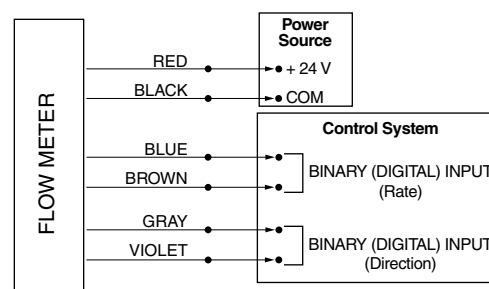

- NOTES:
- * 1. Serial Numbers 115691 and earlier require 24 VDC. Serial Numbers 115692 and higher can accept 24 V AC/DC.
 2. Black wire is common with the pipe (typically earth ground).
 3. For ONICON display module or BTU meter, connect all wires provided. Refer to wiring diagram provided with display or BTU meter.
 4. This is NOT a "loop-powered" instrument. DO NOT connect power to any of the signal output wires (blue, brown, green, orange or white)

APPENDIX B

Internal Wiring Diagrams

**WIRING DIAGRAM
INTERNAL CONNECTIONS FOR
FREQUENCY OUTPUT
FLOW METERS
MODELS F-1100 / F-1200 / F-1300**

For use with serial numbers
115692 and later

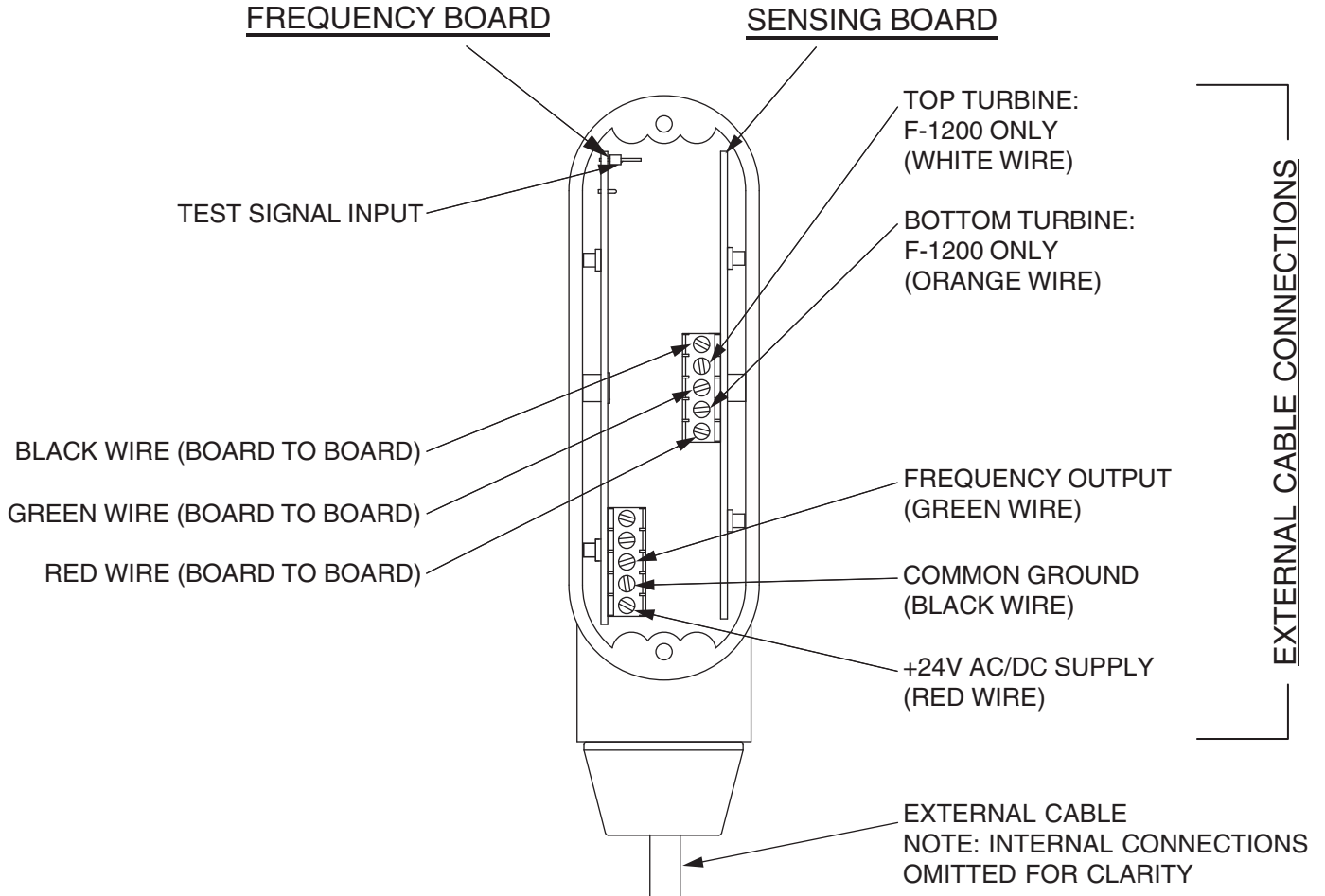

NOTES:

**WIRING DIAGRAM
INTERNAL CONNECTIONS FOR
NON-ISOLATED ANALOG OUTPUT
FLOW METERS
MODELS F-1110 / F-1210 / F-1310**

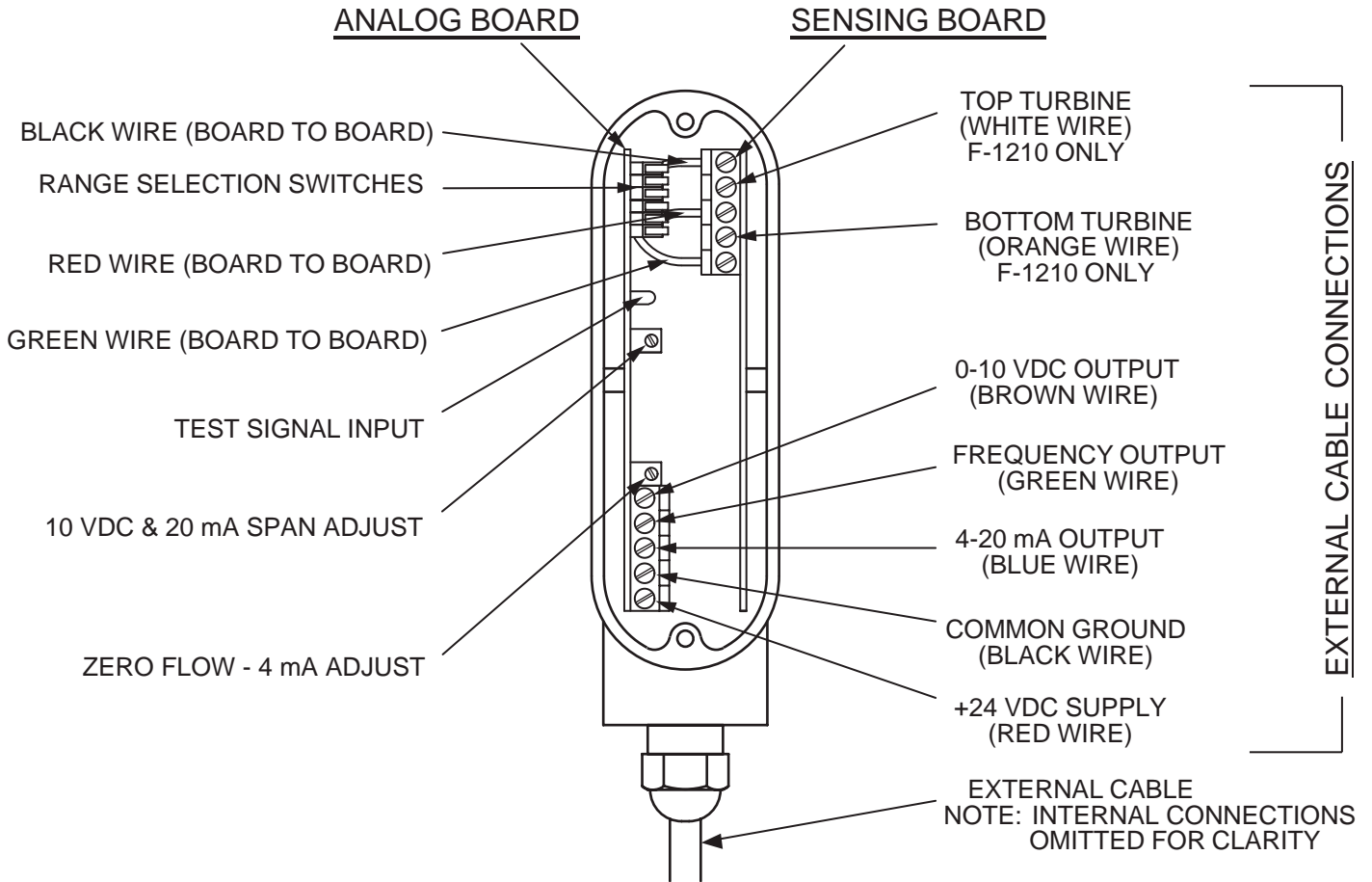

NOTES:

**WIRING DIAGRAM
INTERNAL CONNECTIONS FOR
ISOLATED ANALOG OUTPUT
FLOW METERS
MODELS F-1111 / F-1211 / F-1311**

For use with serial numbers
115692 and later

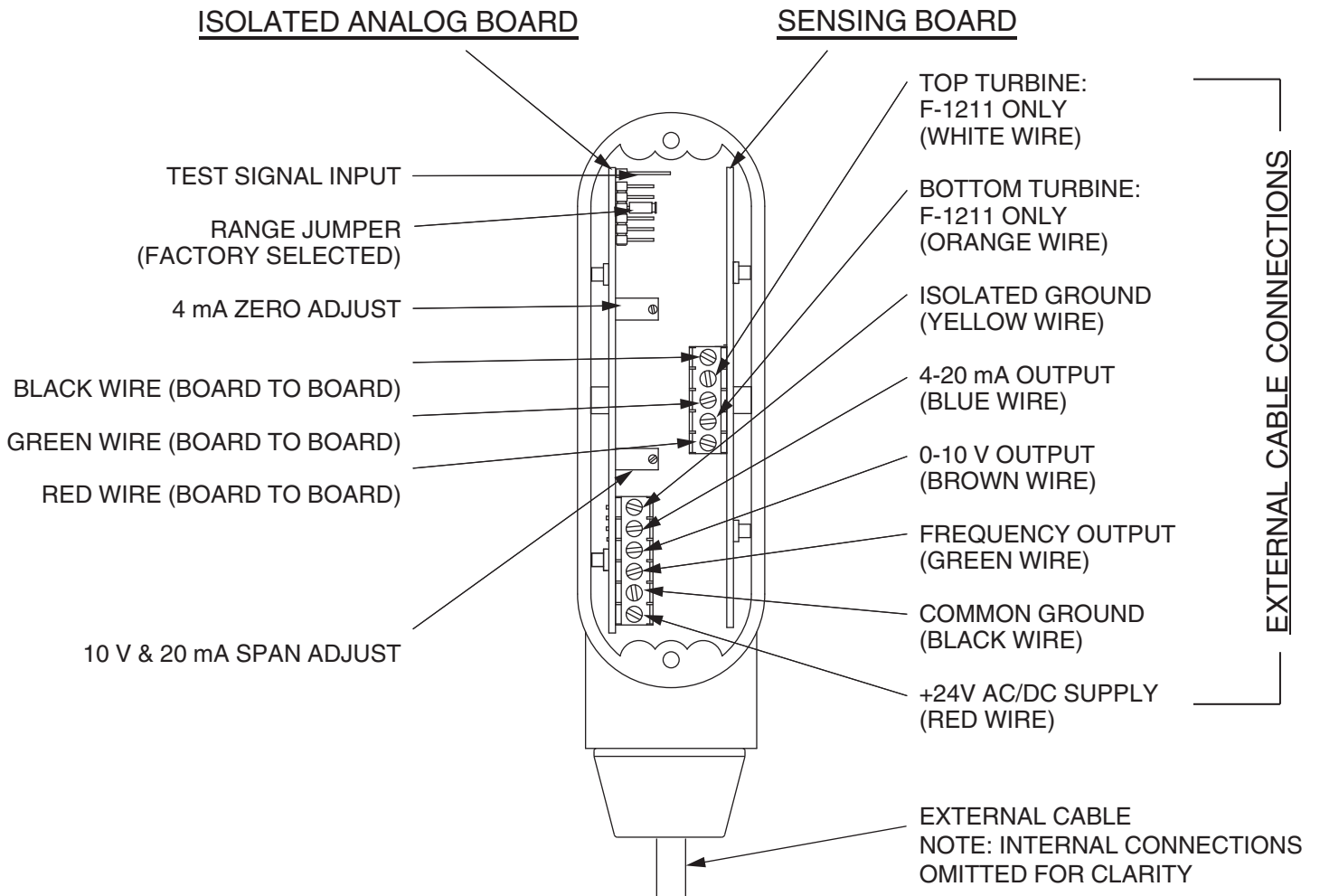

NOTES:

WIRING DIAGRAM INTERNAL CONNECTIONS FOR DIVIDED OUTPUT FLOW METERS MODELS F-1120 / F-1220 / F-1320



For use with serial numbers
115692 and later

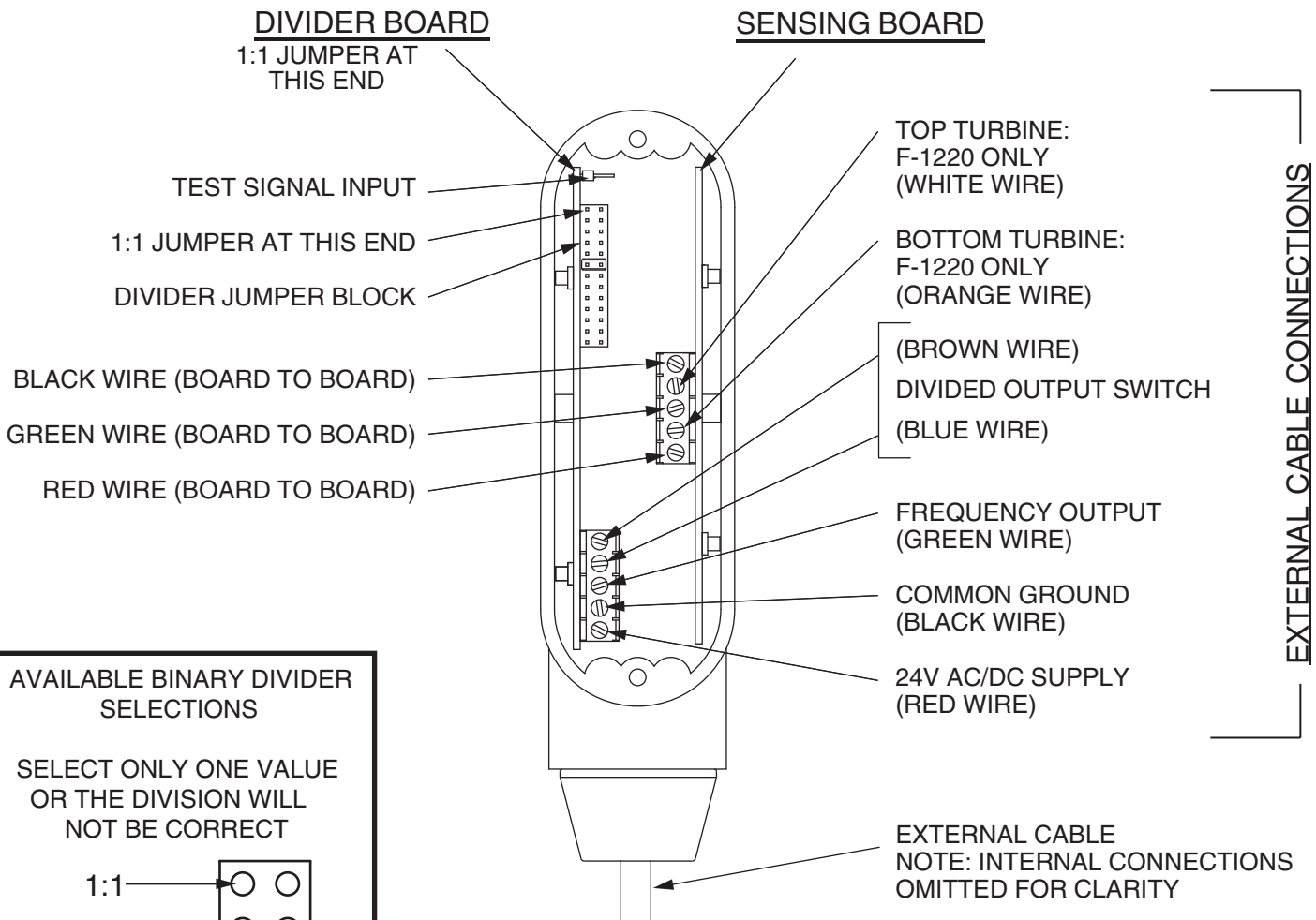

AVAILABLE BINARY DIVIDER SELECTIONS

SELECT ONLY ONE VALUE OR THE DIVISION WILL NOT BE CORRECT

1:1	○	○
1:2	○	○
1:4	○	○
1:8	○	○
1:16	○	○
1:32	○	○
1:64	○	○
1:128	○	○
1:256	○	○
1:512	○	○
1:1024	○	○
1:2048	○	○
1:4096	○	○

NOTES:

WIRING DIAGRAM INTERNAL CONNECTIONS FOR SCALED OUTPUT FLOW METERS MODELS F-1130 / F-1230 / F-1330

For use with serial numbers
115692 and later

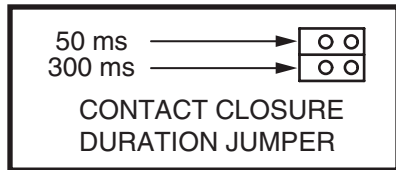
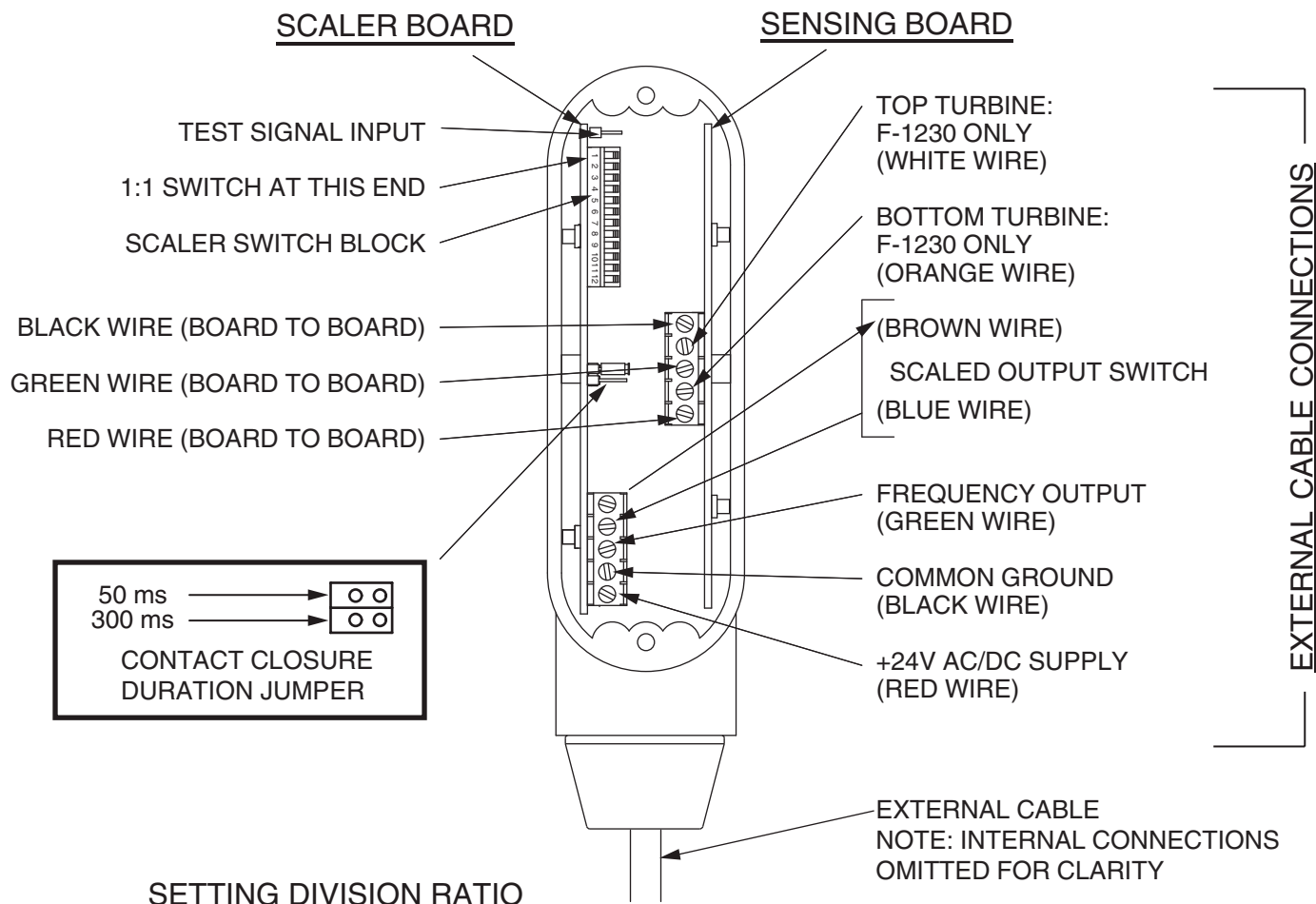

SETTING DIVISION RATIO

Available binary
scaler selections

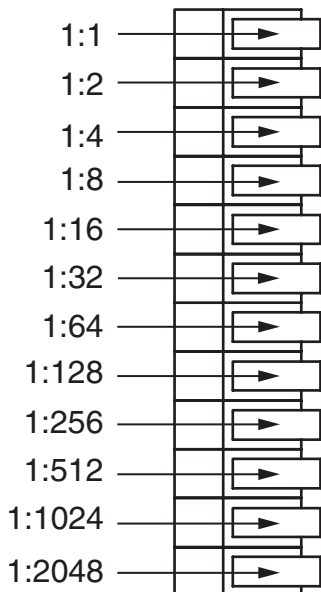

To set division ratio, turn ON each switch that is required to produce an arithmetic sum equal to the desired ratio. For example:

SW	VAL	
1	- 1	
2	- 2	
3	- 4	
4	- 8	
5	- 16	
6	- 32	
7	- 64	
8	- 128	
9	- 256	
10	- 512	
11	- 1024	
12	- 2048	

DESIRED RATIO = 629
Subtract the largest possible switch value.
629 - 512=117
117 - 64=53
53 - 32=21
21 - 16=5
5 - 4=1
1 - 1=0
512+64+32+16+4+1=629
SET SWITCHS
10, 7, 6, 5, 3, & 1
TO "ON"

NOTES:

APPENDIX C

Turbine Assembly Detail Drawings



TURBINE ASSEMBLY DETAILS
for
ALL MODELS IN F-1100 SERIES

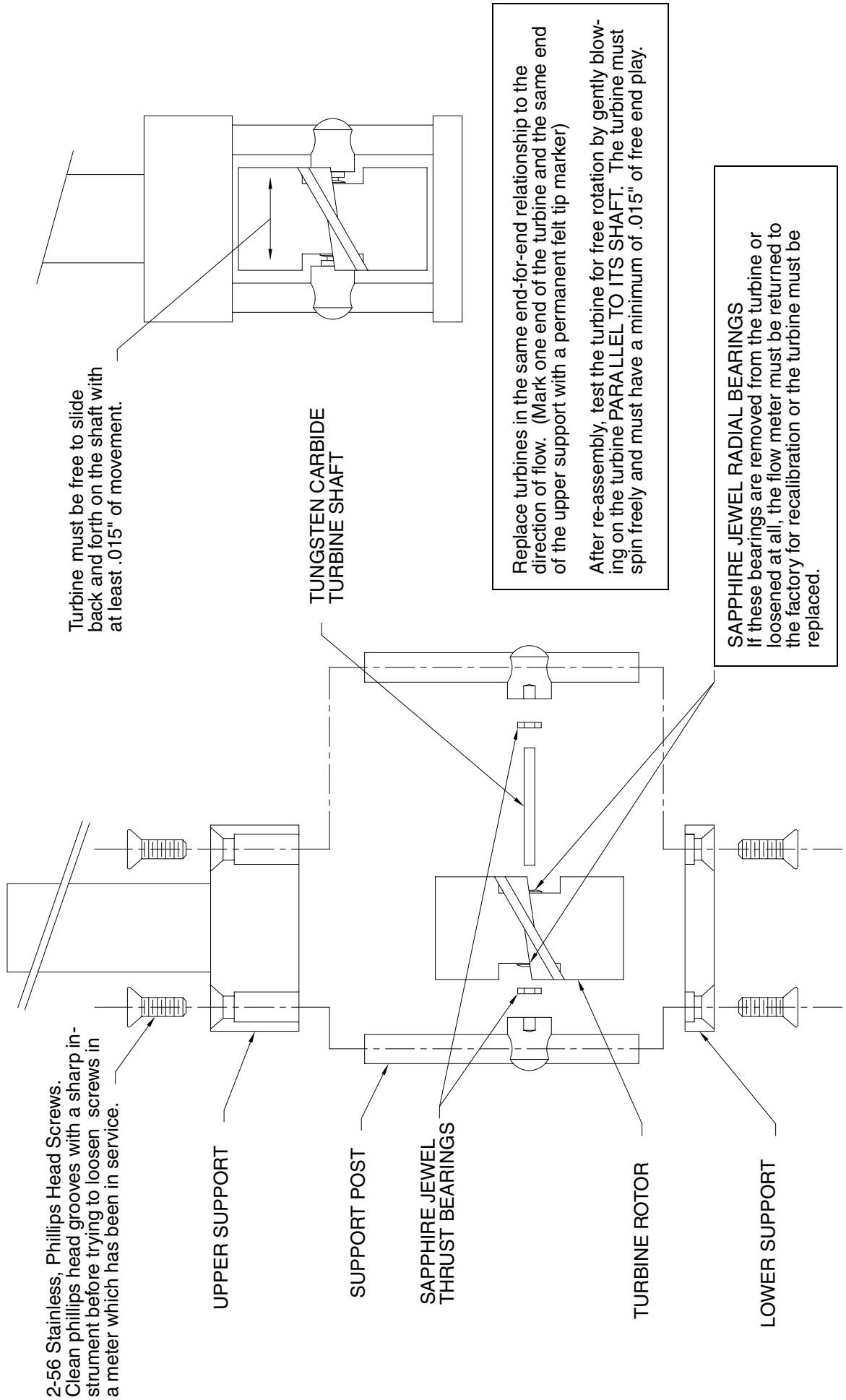

TURBINE ASSEMBLY DETAILS
for
ALL MODELS IN F-1200 SERIES

2-56 STAINLESS, PHILLIPS HEAD SCREWS.
Clean phillips head grooves with a sharp instrument before trying to loosen screws in a meter which has been in service.

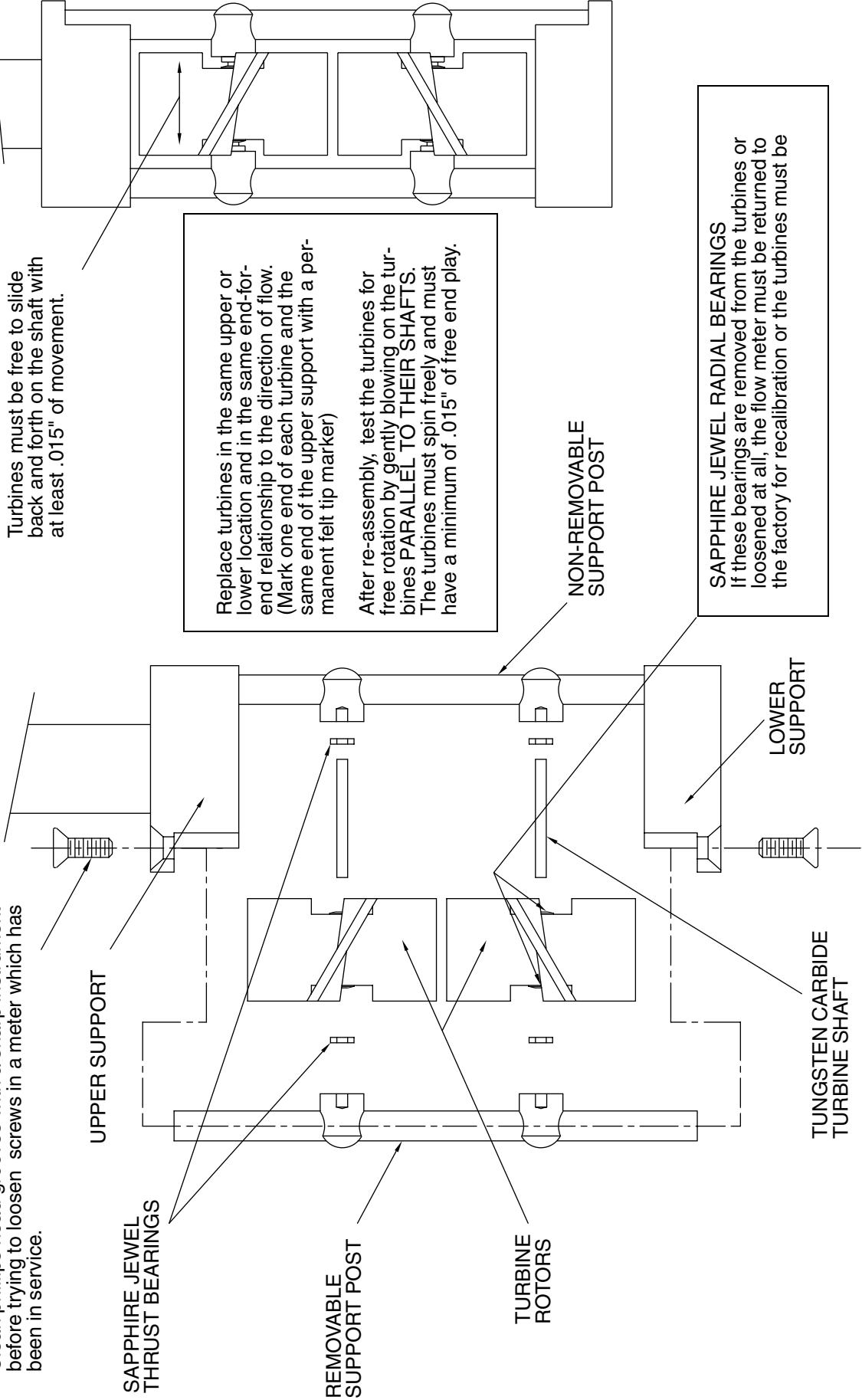

Turbines must be free to slide back and forth on the shaft with at least .015" of movement.

Replace turbines in the same upper or lower location and in the same end-for-end relationship to the direction of flow. (Mark one end of each turbine and the same end of the upper support with a permanent felt tip marker)

After re-assembly, test the turbines for free rotation by gently blowing on the turbines **PARALLEL TO THEIR SHAFTS**. The turbines must spin freely and must have a minimum of .015" of free end play.

SAPPHIRE JEWEL RADIAL BEARINGS
If these bearings are removed from the turbines or loosened at all, the flow meter must be returned to the factory for recalibration or the turbines must be