

Sylk™ I/O Devices

PRODUCT DATA

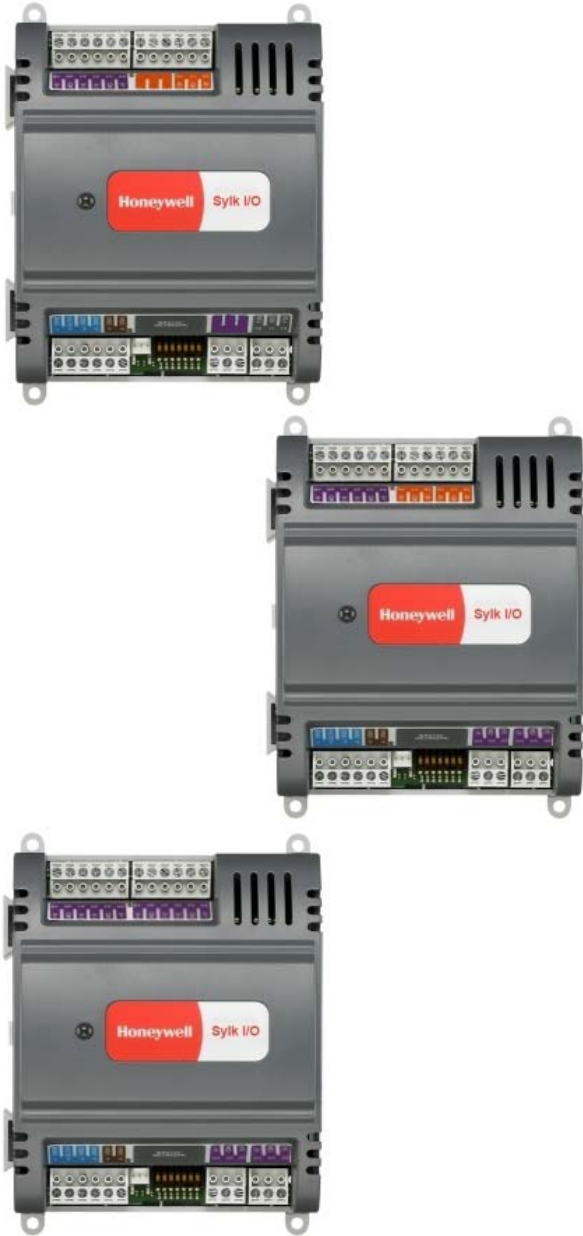

APPLICATION

The Sylk IO devices are part of the Spyder family. The three IO devices are designed to seamlessly integrate with Spyder with relay controllers using only Sylk™ for communication. These devices expand the footprint of a single Spyder, increasing the controller's ability to be applied in applications that require a large amount of physical I/O. The Sylk IO devices are programmable using existing Spyder wire sheets through the Niagara Framework® software. Since the Sylk IO devices are extensions of the Spyder LON and Spyder BACnet controllers, the same Spyder feature will be leveraged in the WebPro workbench tool and the WEBs-AX JACE controller.

The Sylk IO devices are intended for use in HVAC applications that require a programmable controller where the IO count is more than the full sized Spyder point count. All devices provide flexible, universal inputs for external sensors while SIO6042 and SIO4022 provide a combination of analog and digital outputs.

FEATURES

- Expands a single Spyder controller's IO count by 8-12 IO per device.
- Up to three devices for Lon Spydres and up to two devices for BACnet Spydres can be applied.
- Communicates through Sylk™ bus freeing up IO for more applications.
- Program logic resides in a single controller and uses the existing Spyder wire sheet.
- Programming is built directly into the Spyder tool.
- Installation can be done locally or remotely.
- Field configurable and programmable for control, input, and output functions using the Niagara Framework® software.
- All wiring connections are made to removable terminal blocks to simplify device installation and replacement.
- The device housing is UL plenum rated.

Contents

Description	2
Specifications	2
Installation	3
Checkout	9
Device Replacement	10



31-00028-01

DESCRIPTION

The Sylk IO devices are available in three models, as described in Table 1.

Table 1. Device Configurations.

Devices	UI (Universal Input)	DI (Digital Input)	AO (Analog Output)	DO (Digital Output)
SI06042	6	0	4	2
SI04022	4	0	2	2
SI012000	12	0	0	0

Each device is programmable because the user chooses which function blocks to use and how to connect them. It is configurable because each function block has user-defined behavior.

SPECIFICATIONS

General Specifications

Electrical

Rated Voltage: 20-30 Vac; 50/60 Hz

Power Consumption:

100 VA for Sylk IO device and all connected loads

Sylk IO Device Only Load (Excluding Digital Triac Outputs): 3 VA maximum (SIO12000), 4 VA maximum (SIO4022), 5 VA maximum (SIO6042)

Environmental

Operating & Storage Temperature Ambient Rating:

Minimum -40° F (-40° C); Maximum 150° F (65.5° C)

Relative Humidity: 5% to 95% non-condensing

Digital Triac Output (DO) Circuits

Voltage Rating: 20 to 30 Vac @ 50/60Hz

Current Rating: 25 mA to 500 mA continuous, and 800 mA (AC rms) for 60 milliseconds

Analog Output (AO) Circuits

Analog outputs can be individually configured for current or voltage.

ANALOG CURRENT OUTPUTS:

Current Output Range: 4.0 to 20.0 mA

Output Load Resistance: 550 Ohms maximum

ANALOG VOLTAGE OUTPUTS:

Voltage Output Range: 0 to 10.0 Vdc

Maximum Output Current: 10.0 mA

Analog outputs may be configured as digital outputs and operate as follows:

- False (0%) produces 0 Vdc, (0 mA)
- True (100%) produces the maximum 11 Vdc, (22 mA)

Universal Input (UI) Circuits

See Table 2 for the UI circuit specifications.

Table 2. Universal Input Circuit Specifications.

Input Type	Sensor Type	Operating Range
Room/Zone Discharge Air Outdoor Air Temperature	20K Ohm NTC	-40° F to 199° F (-40° C to 93° C)
Outdoor Air Temperature	C7031G ^a	-40° to 120°F (-40° to 49°C)
	C7041F ^a	-40° to 250°F (-40° to 121°C)
	PT1000 (IEC751 3850)	-40° F to 199° F (-40° C to 93° C)
TR23 Setpoint Potentiometer	500 Ohm to 10,500 Ohm	-4° DDC to 4° DDC (-8° DDF to 7° DDF) or 50° F to 90° F (10° C to 32° C)
Resistive Input	Generic	100 Ohms to 100K Ohms
Voltage Input	Transducer, Controller	0 - 10 Vdc
Discrete Input	Dry Contact closure	Open Circuit ≥ 3000Ohms Closed Circuit < 3000Ohms

^a C7031G and C7041F are recommended for use with these controllers, due to improved resolution and accuracy when compared to the PT1000.

ORDERING INFORMATION

When purchasing replacement and modernization products from your TRADELINE® wholesaler or distributor, refer to the TRADELINE® Catalog or price sheets for complete ordering number. If you have additional questions, need further information, or would like to comment on our products or services, please write or phone:

1. Your local Honeywell Environmental and Combustion Controls Sales Office (check white pages of your phone directory).
2. Honeywell Customer Care
1885 Douglas Drive North
Minneapolis, Minnesota 55422-4386
3. <http://customer.honeywell.com> or <http://customer.honeywell.ca>

International Sales and Service Offices in all principal cities of the world. Manufacturing in Belgium, Canada, China, Czech Republic, Germany, Hungary, Italy, Mexico, Netherlands, United Kingdom, and United States.

BEFORE INSTALLATION

The device is available in three models (see Table 1).

Review the power, input, and output specifications on page 2 before installing the device.

- Hardware driven by Triac outputs must have a minimum current draw, when energized, of 25 mA and a maximum current draw of 500 mA.
- Hardware driven by the analog current outputs must have a maximum resistance of 550 Ohms, resulting in a maximum voltage of 11 volts when driven at 20 mA. If resistance exceeds 550 Ohms, voltages up to 18 Vdc are possible at the analog output terminal.



WARNING

Electrical Shock Hazard.

Can cause severe injury, death or property damage.

Disconnect power supply before beginning wiring or making wiring connections to prevent electrical shock or equipment damage.

INSTALLATION

The device must be mounted in a position that allows clearance for wiring, servicing, and removal.

The device may be mounted in any orientation.

IMPORTANT

Avoid mounting in areas where acid fumes or other deteriorating vapors can attack the metal parts of the controller, or in areas where escaping gas or other explosive vapors are present. See Fig. 1 for mounting dimensions.

Mount Device

NOTE: The device may be wired before mounting to a panel or DIN rail.

Terminal blocks are used to make all wiring connections to the device. Attach all wiring to the appropriate terminal blocks (see “Wiring” on page 5).

See Fig. 1 for panel mounting dimensions. See Fig. 2 on page 3 for DIN rail mounting.

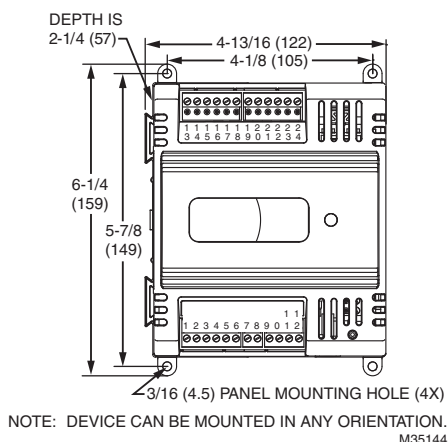

Fig. 1. Device dimensions in in (mm).

Panel Mounting

The device enclosure is constructed of a plastic base plate and a plastic factory-snap-on cover.

NOTE: The device is designed so that the cover does not need to be removed from the base plate for either mounting or wiring.

The device mounts using four screws inserted through the corners of the base plate. Fasten securely with four No. 6 or No. 8 machine or sheet metal screws.

The device can be mounted in any orientation. Ventilation openings are designed into the cover to allow proper heat dissipation, regardless of the mounting orientation.

DIN Rail Mounting

To mount the SIO12000, SIO4022, or SIO6042 device on a DIN rail [standard EN50022; 1-3/8 in. x 9/32 in. (7.5 mm x 35 mm)], refer to Fig. 2 and perform the following steps:

1. Holding the device with its top tilted in towards the DIN rail, hook the two top tabs on the back of the device onto the top of the DIN rail.
2. Push down and in to snap the two bottom flex connectors of the device onto the DIN rail.

IMPORTANT

To remove the device from the DIN rail, perform the following:

1. Push straight up from the bottom to release the top tabs.
2. Rotate the top of the device out towards you and pull the controller down and away from the DIN rail to release the bottom flex connectors.

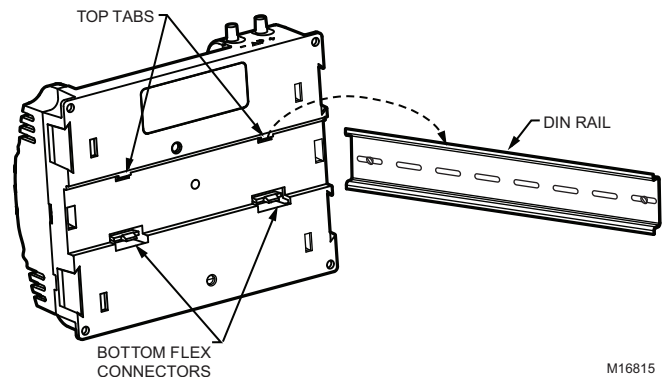

Fig. 2. Controller DIN rail mounting (models SIO12000, SIO4022, and SIO6042).

Power

Before wiring the controller and device, determine the input and output device requirements for each controller and device used in the system. Select input and output devices compatible with the controller, device, and the application. Consider the operating range, wiring requirements, and the environment conditions when selecting input/output devices. When selecting actuators for modulating applications consider using floating control. In direct digital control applications, floating actuators will generally provide control action equal to or better than an analog input actuator for lower cost.

Determine the location of controllers, sensors, actuators and other input/output devices and create wiring diagrams.

The application engineer must review the control job requirements. This includes the sequences of operation for the controller, and for the system as a whole. Usually, there are variables that must be passed between controllers that are required for optimum system-wide operation. Typical examples are the TOD, Occ/Unocc signal, the outdoor air temperature, the demand limit control signal, and the smoke control mode signal.

It is important to understand these interrelationships early in the job engineering process, to ensure proper implementation when configuring the controllers.

Power Budget

A power budget must be calculated for each device to determine the required transformer size for proper operation. A power budget is simply the summing of the maximum power draw ratings (in VA) of all the devices to be controlled. This includes the controller itself and any devices powered from the controller, such as equipment actuators (ML6161 or other motors) and various contactors and transducers.

IMPORTANT

- If a controller is used on Heating and Cooling Equipment (UL 1995, U.S. only) and transformer primary power is more than 150 volts, connect the transformer secondary common to earth ground (see Fig. 5 on page 6).
- When multiple controllers operate from a single transformer, connect the same side of the transformer secondary to the same power input terminal in each device. The earth ground terminal (terminal 3) must be connected to a verified earth ground for each controller in the group (see Fig. 6 on page 7).

POWER BUDGET CALCULATION EXAMPLE

Table 3 is an example of a power budget calculation for typical Spyder LON controller and Sylk IO devices. While the example is shown for only these models, the process is applicable for all controller and device configurations.

Table 3. Power budget calculation example.

Device	VA Information	Obtained From
PUL6438SR	5.0	Spyder LON Product Data Sheet
SIO6042	5.0 ^a	See "Specifications" on page 2.
R8242A Contactor fan rating	21.0	TRADELINE® Catalog inrush rating
D/X Stages	0.0	For example, assume cooling stage outputs are wired into a compressor control circuit and have no impact on the budget.
M6410A Steam Heating Coil Valve	0.7	TRADELINE® Catalog, 0.32A 24 Vac
TOTAL	31.7	

^a Excludes the use of digital Triac outputs.

The system example above requires 31.7 VA of peak power. Therefore, a 100 VA AT92A transformer could be used to power one controller and device of this type. Because the total peak power is less than 33 VA, this same transformer could be used to power this configuration and meet NEC Class 2 restrictions (no greater than 100 VA).

See Fig. 4–Fig. 6 beginning on page 6 for illustrations of controller power wiring. See Table 4 for VA ratings of various devices.

Table 4. VA ratings for transformer sizing.

Device	Description	VA
PVL0000AS, PVL4022AS, and PVL6436AS controllers and Series 60 Floating Damper Actuator	Controller and Actuator ^a	9.0
PUL1012S, PUL4024S, PUL6438S, PVL4024NS, or PVL6438NS	Controller ^a	5.0
SIO12000	IO Device ^a	3.0
SIO4022		4.0
SIO642		5.0
ML684	Versadrive Valve Actuator	12.0
ML6161	Damper Actuator, 35 lb-in.	2.2
ML6185	Damper Actuator SR 50 lb-in	12.0
ML6464	Damper Actuator, 66 lb-in.	3.0
ML6474	Damper Actuator, 132 lb-in.	3.0
R6410A	Valve Actuator	0.7
R8242A	Contactors	21.0

^a When used, each digital Triac output can add an additional 22 VA (peak) and 12 VA long-term.

For contactors and similar devices, the in-rush power ratings should be used as the worst case values when performing power budget calculations. Also, the application engineer must consider the possible combinations of simultaneously energized outputs and calculate the VA ratings accordingly. The worst case, which uses the largest possible VA load, should be determined when sizing the transformer.

Each device requires 24 Vac power from an energy-limited Class II power source. To conform to Class II restrictions (U.S. only), transformers must not be larger than 100 VA. A single transformer can power more than one device.

GUIDELINES FOR POWER WIRING ARE AS FOLLOWS:

- For multiple devices operating from a single transformer, the same side of the transformer secondary must be connected to the same power input terminal in each device. The earth ground terminal must be connected to a verified earth ground for each device in the group (see Fig. 6 on page 7). Device configurations are not necessarily limited to three devices, but the total power draw, including accessories, cannot exceed 100 VA when powered by the same transformer (U.S. only).
- See Fig. 5 on page 6 for device power wiring used in UL 1995 equipment (U.S. only).

- Many devices require all loads to be powered by the same transformer that powers the device.
- Keep the earth ground connection wire run as short as possible (refer to Fig. 4–Fig. 6 beginning on page 6).
- Do not connect earth ground to the device's digital or analog ground terminals (refer to Fig. 4 and Fig. 6).
- Unswitched 24 Vac power wiring can be run in the same conduit as the LONWORKS® Bus cable.

Line-Loss

Devices must receive a minimum supply voltage of 20 Vac. If long power or output wire runs are required, a voltage drop due to Ohms Law (I x R) line-loss must be considered. This line-loss can result in a significant increase in total power required and thereby affect transformer sizing. The following example is an I x R line-loss calculation for a 200 ft. (61m) run from the transformer to a device drawing 37 VA and using two 18 AWG (1.0 sq mm) wires.

The formula is:

$$\text{Loss} = [\text{length of round-trip wire run (ft.)}] \times [\text{resistance in wire (ohms per ft.)}] \times [\text{current in wire (amperes)}]$$

From specification data:

18 AWG twisted pair wire has a resistance of 6.52 ohms per 1000 feet.

$$\text{Loss} = [(400 \text{ ft.}) \times (6.52/1000 \text{ ohms per ft.})] \times [(37 \text{ VA})/(24\text{V})] = 4.02 \text{ volts}$$

This means that four volts are going to be lost between the transformer and the device. To assure the device receives at least 20 volts, the transformer must output more than 24 volts. Because all transformer output voltage levels depend on the size of the connected load, a larger transformer outputs a higher voltage than a smaller one for a given load. Fig. 3 shows this voltage load dependence.

In the preceding I x R loss example, even though the device load is only 37 VA, a standard 40 VA transformer is not sufficient due to the line-loss. Looking at Fig. 3, a 40 VA transformer is just under 100 percent loaded (for the 37 VA controller) and has a secondary voltage of 22.9 volts. (Use the lower edge of the shaded zone in Fig. 3 that represents the worst case conditions.) When the I x R loss of four volts is subtracted, only 18.9 volts reaches the device. This is not enough voltage for proper operation.

In this situation, the engineer has three alternatives:

1. Use a larger transformer. For example, if an 80 VA model is used, an output of 24.4 volts, minus the four volt line-loss, supplies 20.4V to the device (see Fig. 3). Although acceptable, the four-volt line-loss in this example is higher than recommended.

IMPORTANT

No installation should be designed where the line-loss is greater than two volts. This allows for nominal operation if the primary voltage drops to 102 Vac (120 Vac minus 15 percent).

2. Use heavier gauge wire for the power run. 14 AWG (2.0 sq mm) wire has a resistance of 2.57 ohms per 1,000 ft. Using the preceding formula results in a line-loss of only 1.58 volts (compared with 4.02 volts). This

would allow a 40 VA transformer to be used. 14 AWG (2.0 sq mm) wire is the recommended wire size for 24 Vac wiring.

3. Locate the transformer closer to the device. This reduces the length of the wire run, and the line-loss.

The issue of line-loss is also important in the case of the output wiring connected to the Triac digital outputs. The same formula and method are used. Keep all power and output wire runs as short as practical. When necessary, use heavier gauge wire, a bigger transformer, or install the transformer closer to the controller.

To meet the National Electrical Manufacturers Association (NEMA) standards, a transformer must stay within the NEMA limits. The chart in Fig. 3 shows the required limits at various loads.

With 100 percent load, the transformer secondary must supply between 23 and 25 volts to meet the NEMA standard. When a purchased transformer meets the NEMA standard DC20-1986, the transformer voltage regulating ability can be considered reliable. Compliance with the NEMA standard is voluntary.

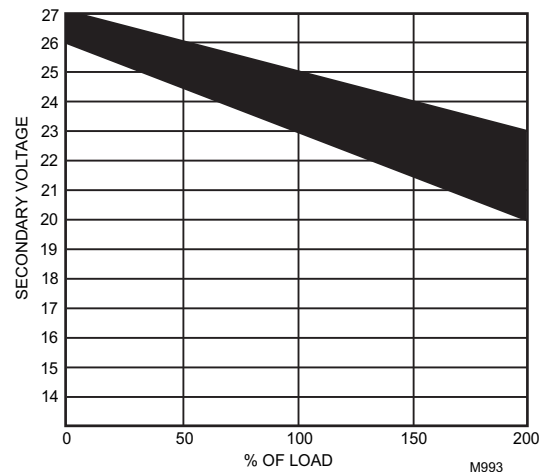

Fig. 3. NEMA Class 2 transformer voltage output limits.

The Honeywell transformers listed in Table 5 meet the NEMA standard DC20-1986.

Table 5. Honeywell transformers that meet NEMA standard DC20-1986.

Transformer Type	VA Rating
AT40A	40
AT72D	40
AT87A	50
AK3310 Assembly	100

NOTE: The AT88A and AT92A transformers do not meet the voluntary NEMA standard DC20-1986.

Wiring

All wiring must comply with applicable electrical codes and ordinances, or as specified on installation wiring diagrams. Device wiring is terminated to the screw terminal blocks located on the top and the bottom of the device.

⚠ WARNING

Electrical Shock Hazard.
Can cause severe injury, death or property damage.
 Disconnect power supply before beginning wiring or making wiring connections, to prevent electrical shock or equipment damage.

NOTES:

- For multiple controllers and devices operating from a single transformer, the same side of the transformer secondary must be connected to the same power input terminal in each controller. Controller and device configurations will not necessarily be limited to three devices, but the total power draw, including accessories, cannot exceed 100 VA when powered by the same transformer (U.S. only). For power and wiring recommendations, See “Power” on page 3. The earth ground terminal (terminal 3) must be connected to a verified earth ground for each controller or device in the group (see Fig. 6 on page 7).
- All loads on the controller and device must be powered by the same transformer that powers the controller and device themselves. A controller can use separate transformers for controller power and output power.
- Keep the earth ground connection (terminal 3) wire run as short as possible.
- Do not connect the universal input COM terminals, analog output COM terminals or the digital input/output COM terminals to earth ground. Refer to Fig. 4–Fig. 6 for wiring examples.

The 24 Vac power from an energy limited Class II power source must be provided to the controller and device. To conform to Class II restrictions (U.S. only), the transformer must not be larger than 100 VA.

Fig. 4 depicts a single controller using one transformer.

IMPORTANT

Power must be off prior to connecting to or removing connections from the 24 Vac power (24 Vac/24 Vac COM), earth ground (EGND), and 20 Vdc power (20 Vdc) terminals.

IMPORTANT

Use the heaviest gauge wire available, up to 14 AWG (2.0 sq mm), with a minimum of 18 AWG (1.0 sq mm), for all power and earth ground wiring.

Screw-type terminal blocks are designed to accept up to one 14 AWG (2.0 sq mm) conductor or up to two 18 AWG (1.0 sq mm) conductors. More than two wires that are 18 AWG (2.0 sq mm) can be connected with a wire nut. Include a pigtail with this wire group and attach the pigtail to the terminal block.

IMPORTANT

*If the controller and device are used on **Heating and Cooling Equipment (UL 1995, U.S. only)** and the transformer primary power is more than 150 volts, connect terminal 2, (the 24 Vac common [24 VAC COM] terminal) to earth ground (see Fig. 5). For these applications, only one controller and device can be powered by each transformer.*

NOTES:

- Unswitched 24 Vac power wiring can be run in the same conduit as the LONWORKS® cable.
- Maintain at least a 3 in. (7.6 cm) separation between Triac outputs and LONWORKS® wiring throughout the installation.

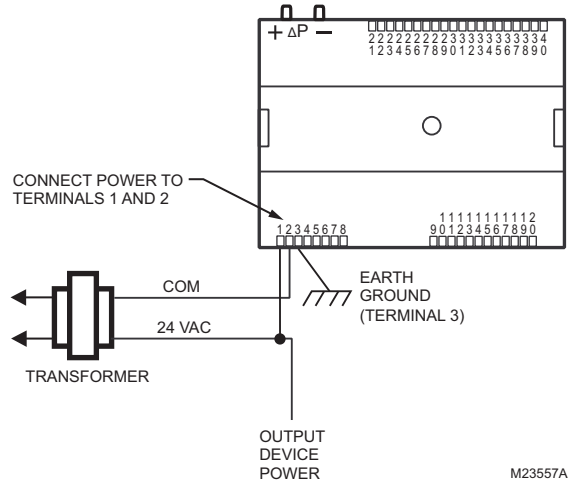
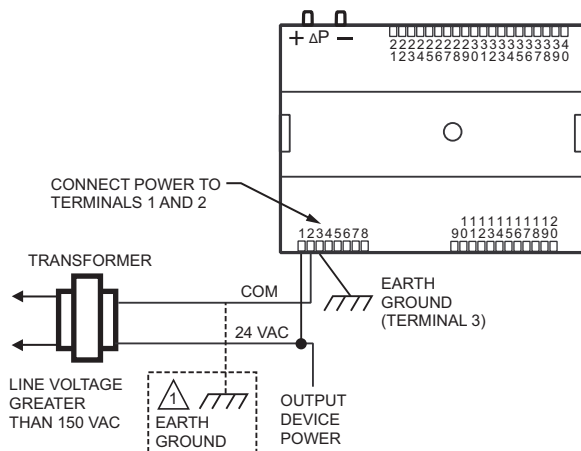

Fig. 4. Power wiring details for one controller per transformer.



⚠ IF THE CONTROLLER IS USED IN UL 1995 EQUIPMENT AND THE PRIMARY POWER IS MORE THAN 150 VOLTS, GROUND 24 VAC COM SIDE OF TRANSFORMER SECONDARY.

Fig. 5. Transformer power wiring details for one controller used in UL 1995 equipment (U.S. only).

More than one controller and device can be powered by a single transformer. Fig. 6 shows power wiring details for multiple controllers.

NOTE: Controller and device configurations are not necessarily limited to three devices, but the total power draw, including accessories, cannot exceed 100 VA when powered by the same transformer (U.S. only). For power wiring recommendations, see “Power” on page 3.

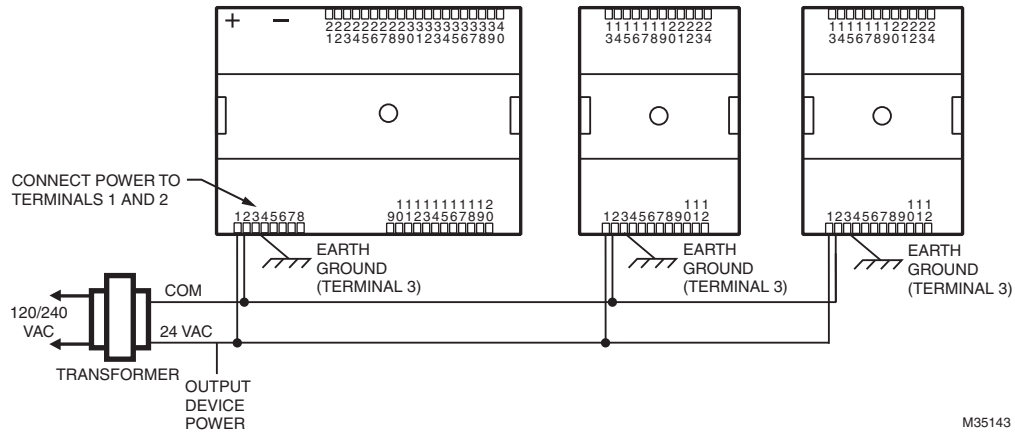

Fig. 6. Power wiring details for two or more controllers and devices per transformer.

Communications

Sylk™ Bus

Sylk is a two wire, polarity insensitive bus that provides both 18 VDC power and communications between a Sylk-enabled sensor, Sylk-enabled device, and a Sylk-enabled controller. Using Sylk-enabled sensors and devices saves I/O on the controller and is faster and cheaper to install since only two wires are needed and the bus is polarity insensitive. Sylk sensors and devices are configured using the latest release of the Spyder Tool for WEBPro and WEBStation. Using 18 AWG wire, the maximum wire length for Sylk is 200 ft.

For Spydres and Sylk IO devices, use the Resource Usage View in the Spyder tool to determine the maximum number of devices.

Setting the Device Bus Address Dial

Each device on a Sylk bus must use a different bus address, and there may be multiple Sylk IOs wired on a single Sylk bus. To change the bus address of a device, adjust the address dipswitches to match that of the desired bus address (1–15). Use the bus address label, shown in Fig. 7, as a reference. The default address for Sylk IOs is 1. The address on the device must match the address in the configuration tool.

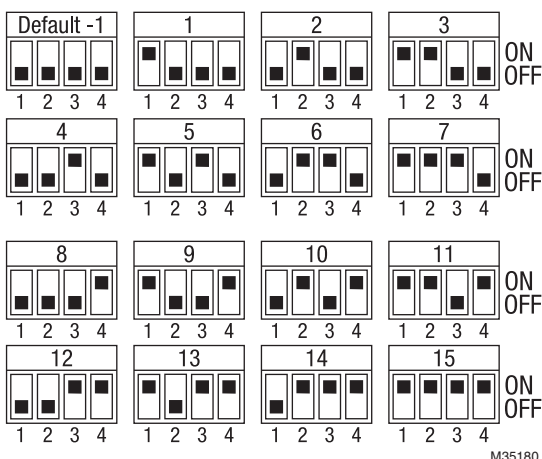

Fig. 7. Bus address settings.

Wiring Method



WARNING

Electrical Shock Hazard.

Can cause severe injury, death or property damage. Disconnect power supply before beginning wiring, or making wiring connections, to prevent electrical shock or equipment damage.

NOTE: When attaching two or more wires to the same terminal, other than 14 AWG (2.0 sq mm), be sure to twist them together. Deviation from this rule can result in improper electrical contact (see Fig. 8).

Each terminal can accommodate the following gauges of wire:
 — Single wire: from 22 AWG to 14 AWG solid or stranded
 — Multiple wires: up to two 18 AWG stranded, with 1/4 watt wire-wound resistor

Prepare wiring for the terminal blocks, as follows:

1. Strip 1/2 in. (13 mm) insulation from the conductor.
2. Cut a single wire to 3/16 in. (5 mm). Insert the wire in the required terminal location and tighten the screw.
3. If two or more wires are being inserted into one terminal location, twist the wires together a minimum of three turns before inserting them (see Fig. 8).
4. Cut the twisted end of the wires to 3/16 in. (5 mm) before inserting them into the terminal and tightening the screw.
5. Pull on each wire in all terminals to check for good mechanical connection.

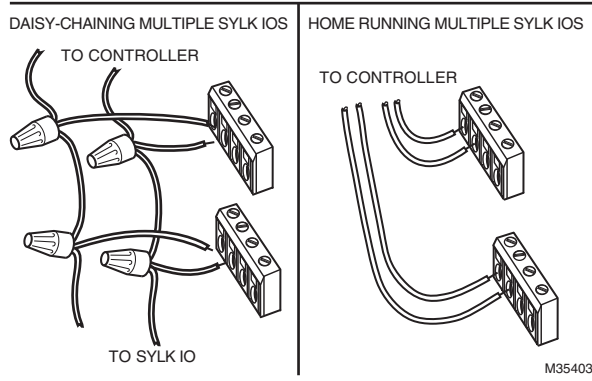
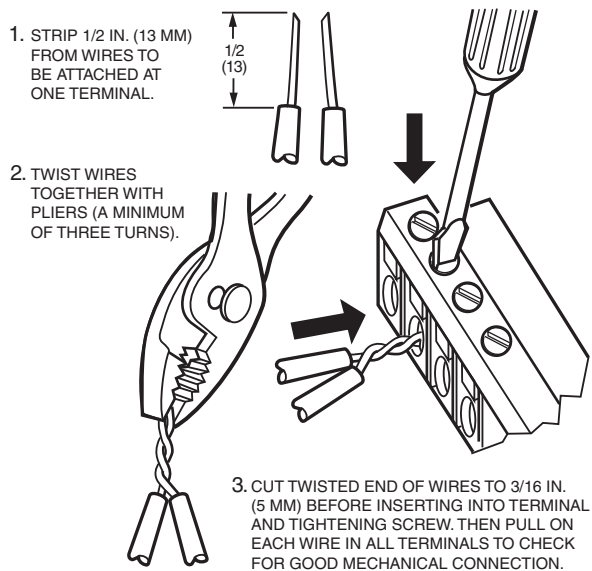

Fig. 8. Attaching two or more wires at terminal blocks.

Wiring Details

Each device is shipped with the digital outputs, which switch the 24 Vac to the load (High Side).

The analog outputs (AO) are used to control modulating heating, cooling and economizer equipment. Any AO may be used as a digital output, as follows:

- False (0%) produces 0 Vdc, (0 mA)
- True (100%) produces the maximum 11 Vdc (22 mA)

Table 6. Description of wiring terminal connections for SIO4022.

SIO4022 Terminals	Label	Connection
1	24VAC	24VAC Power
2	24VAC COM	24VAC-COMMON
3	EGND	Chassis/Earth Ground
4	N/A	Not Applicable
5	S-BUS	Sylk
6	S-BUS	Sylk
7	N/A	Not Applicable
8	N/A	Not Applicable

Table 6. Description of wiring terminal connections for SIO4022.

SIO4022 Terminals	Label	Connection
9	N/A	Not Applicable
10	DO-1	Discrete Triac Output
11	COM	DO COMMON
12	DO-2	Discrete Triac Output
13	N/A	Not Applicable
14	N/A	Not Applicable
15	N/A	Not Applicable
16	AO-2	Analog Output
17	COM	AO COMMON
18	AO-1	Analog Output
19	UI-4	Universal Input
20	COM	UI COMMON
21	UI-3	Universal Input
22	UI-2	Universal Input
23	COM	UI COMMON
24	UI-1	Universal Input

Table 7. Description of wiring terminal connections for SIO12000.

SIO12000 Terminals	Label	Connection
1	24VAC	24VAC Power
2	24VAC COM	24VAC-COMMON
3	EGND	Chassis/Earth Ground
4	N/A	Not Applicable
5	S-BUS	Sylk
6	S-BUS	Sylk
7	UI-1	Universal Input
8	COM	UI COMMON
9	UI-2	Universal Input
10	UI-3	Universal Input
11	COM	UI COMMON
12	UI-4	Universal Input
13	UI-12	Universal Input
14	COM	UI COMMON
15	UI-11	Universal Input
16	UI-10	Universal Input
17	COM	UI COMMON
18	UI-9	Universal Input
19	UI-8	Universal Input
20	COM	UI COMMON

Table 7. Description of wiring terminal connections for SIO12000. (Continued)

SIO12000 Terminals	Label	Connection
21	UI-7	Universal Input
22	UI-6	Universal Input
23	COM	UI COMMON
24	UI-5	Universal Input

Table 8. Description of wiring terminal connections for SIO6042.

SIO6042 Terminals	Label	Connection
1	24VAC	24VAC Power
2	24VAC COM	24VAC-COMMON
3	EGND	Chassis/Earth Ground
4	N/A	Not Applicable
5	S-BUS	Sylk
6	S-BUS	Sylk
7	UI-1	Universal Input
8	COM	UI COMMON
9	UI-2	Universal Input
10	DO-1	Discrete Triac Output
11	COM	DO COMMON
12	DO-2	Discrete Triac Output
13	AO-4	Analog Output
14	COM	AO COMMON
15	AO-3	Analog Output
16	AO-2	Analog Output
17	COM	AO COMMON
18	AO-1	Analog Output
19	UI-6	Universal Input
20	COM	UI COMMON
21	UI-5	Universal Input
22	UI-4	Universal Input
23	COM	UI COMMON
24	UI-3	Universal Input

IMPORTANT

If the device is not connected to a good earth ground, the device's internal transient protection circuitry is compromised and the function of protecting the device from noise and power line spikes cannot be fulfilled. This could result in a damaged circuit board and require replacement of the device. Refer to installation diagrams for specific wiring.

CHECKOUT

Step 1. Check Installation and Wiring

Inspect all wiring connections at the device terminals, and verify compliance with installation wiring diagrams. If any wiring changes are required, *first* be sure to remove power from the controller *before* starting work. Pay particular attention to:

- 24 Vac power connections. Verify that multiple devices being powered by the same transformer are wired with the transformer secondary connected to the same input terminal numbers on each device. Use a meter to measure 24 Vac at the appropriate terminals (see Fig. 6 on page 7). Device configurations are not necessarily limited to three devices, but the total power draw, including accessories, cannot exceed 100 VA when powered by the same transformer (U.S. only).
- Be sure that each device has terminal 3 wired to a verified earth ground, using a wire run as short as possible with the heaviest gauge wire available, up to 14 AWG (2.0 sq mm) with a minimum of 18 AWG (1.0 sq mm) for each controller in the group (see Fig. 6 on page 7).
- Verify that Triac wiring of the digital outputs to external devices uses the proper load power and 24 Vac common terminal (digital output common terminals) for High-Side switching.

NOTE: All wiring must comply with applicable electrical codes and ordinances or as specified on installation wiring diagrams.

For guidelines for wiring run lengths and power budget, see “Power” on page 3.

Step 2. Startup

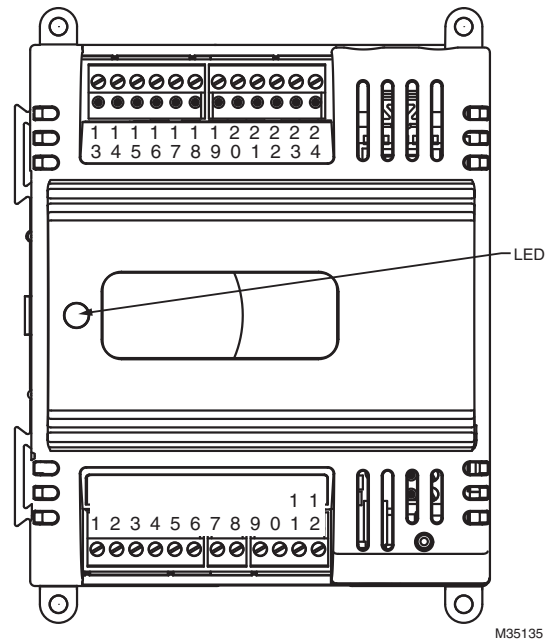

Fig. 9. LED, service pin, and network connection locations.

DEVICE STATUS LED:

The LED on the front of the device provides a visual indication of the status of the device. When the device receives power, the LED appears in one of the following allowable states, as described in Table 3.

Table 9. Status LED States.

LED State	Blink Rate	Status or Condition
OFF	not applicable	No power to processor, LED damaged, low voltage to board, first second of power up, or loader damaged.
ON	ON steady; not blinking	Processor not operating. Application Program CRC being checked. This takes 1-2 seconds and occurs on each restart (power up, reset and reflash, and following configuration file download).
Very Slow Blink (continuous)	1 second ON, 1 second OFF	Device is operating normally.
Slow Blink (continuous)	0.5 second ON, 0.5 second OFF	Device alarm is active or device in process of configuration file download.

Step 3. Checkout Completion

At this point the device is installed and powered. To complete the checkout, the NIAGARA FRAMEWORK® application (run on a PC) is used to configure the I/O and functions of the controller and device.

DEVICE REPLACEMENT

There are no serviceable or repairable parts inside the device.

! WARNING

Fire, Explosion, or Electrical Shock Hazard.
Can cause severe injury, death or property damage.
 Do not attempt to modify the physical or electrical characteristics of this device in any way. Replace the device if troubleshooting indicates a malfunction.

! WARNING

Electrical Shock Hazard.
Can cause severe injury, death or property damage.
 Disconnect power supply before beginning device replacement to prevent electrical shock or equipment damage.

Terminal Block Removal

To simplify device replacement, all terminal blocks are designed to be removed with the wiring connections intact and then re-installed on the new device. See Fig. 10 and refer to the following procedure:

IMPORTANT

To prevent bending or breaking the alignment pins on longer terminal blocks, insert the screwdriver at several points to evenly and gradually lift up the terminal block.

Insert the screwdriver blade no more than 1/8 in. (3 mm) to prevent damage to the terminal block alignment pins on the device circuit board.

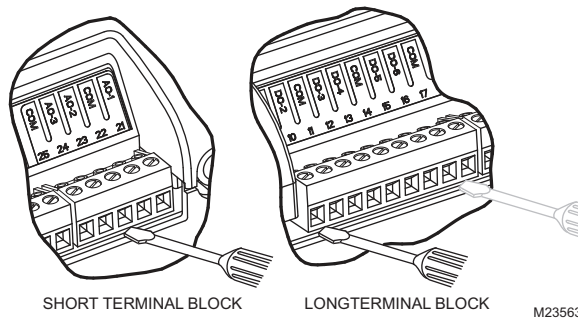

Fig. 10. Removing Terminal Blocks.

- Use a thin-bladed screwdriver to evenly raise the terminal block from its alignment pins:
 - For short terminal blocks (1 to 5 terminals), insert screwdriver blade in the center of the terminal block and use a back and forth twisting motion to gently raise the terminal block from its alignment pins 1/4 in. (6.35 mm).
 - For long terminal blocks (6 or more terminals), insert screwdriver blade on one side of the terminal block and gently rotate the blade 1/4 turn. Then, move to the other side of the terminal block and do the same. Repeat until the terminal block is evenly raised 1/4 in. (6.35 mm) from its alignment pins.
- Once the terminal block is raised 1/4 in. (6.35 mm) from its alignment pins, grasp the terminal block at its center (for long terminal blocks grasp it at each end) and pull it straight up.

Device Replacement (SIO12000, SIO4022, and SIO6042)

Perform the following to replace the SIO12000, SIO4022, and SIO6042 devices:

- Remove all power from the device.
- Remove the terminal blocks (See “Terminal Block Removal” on page 10.).
- Remove the old device from its mounting.

IMPORTANT

(FOR DEVICES MOUNTED TO A DIN RAIL):

- Push straight up from the bottom to release the top pins.*
- Rotate the top of the device outwards to release the bottom flex connectors (see Fig. 2 on page 3).*
- Mount the new device (See “Installation” on page 3.).
- Replace the terminal blocks:
 - Insert each terminal block onto its alignment pins.
 - Press straight down to firmly seat it.
 - Repeat for each terminal block.
- Restore power to the device.
- Perform “Checkout” on page 9.

By using this Honeywell literature, you agree that Honeywell will have no liability for any damages arising out of your use or modification to, the literature. You will defend and indemnify Honeywell, its affiliates and subsidiaries, from and against any liability, cost, or damages, including attorneys' fees, arising out of, or resulting from, any modification to the literature by you.

Automation and Control Solutions

Honeywell International Inc.
1985 Douglas Drive North
Golden Valley, MN 55422
customer.honeywell.com

Honeywell

© U.S. Registered Trademark
© 2014 Honeywell International Inc.
31-00028—01 M.S. 10-14
Printed in United States