

391936 Natural Gas and 391937 LP Gas Conversion Kits

FOR V800 AND VR8440 FAMILY OF
COMBINATION GAS CONTROLS

INSTALLATION INSTRUCTIONS

APPLICATION

The 391936 and 391937 Conversion Kits are used on V400, VR400, VR800, VR800, VR8440, VR8450, and Combination Gas Controls equipped with V5306 Standard-Opening Pressure Regulators. The 391936 Conversion Kit changes an LP gas control to a natural gas control. The 391937 Conversion Kit changes a natural gas control to an LP gas control. Kits include a new cap screw, tapered spring, and conversion label.

INSTALLATION

When Installing This Product...

1. Read these instructions carefully. Failure to follow them can damage product or cause a hazardous condition.
2. Check ratings given in the instructions and on product to make sure product is suitable for your application.
3. Make sure installer is a trained, experienced service technician.
4. After completing installation, use these instructions to check out product operation.

WARNING

Fire or Explosion Hazard.

Can cause severe injury, death or property damage.

Follow these warning instructions exactly:

1. Disconnect power supply before wiring to prevent electrical shock or equipment damage.
2. To avoid dangerous accumulation of fuel gas, turn off gas supply at appliance service valve before starting installation and perform Gas Leak Test after completion of installation.
3. Use only your hand to turn gas control knob. Never use any tools. If gas control knob will not operate by hand, the gas control should be replaced by a qualified service technician. Force or attempted repair can result in fire or explosion.
4. Change main and pilot burner orifices to meet appliance manufacturer specifications.

To convert from one gas to another:

1. Turn off gas supply at the appliance service valve.
2. Remove regulator cap screw and pressure regulator adjusting screw. See Fig. 1.
3. Remove the existing spring.
4. Insert the replacement spring with the tapered end down. See Fig. 2.
5. Install the new plastic pressure regulator adjustment screw. Make sure the screw top is flush with the regulator top.
6. Turn pressure regulator adjustment screw clockwise  six (6) complete turns. The preliminary pressure setting is approximately 10.0 in. wc (2.5 kPa) for LP gas regulator (391937) and 3.5 in. wc (0.9 kPa) for natural gas regulator (391936).
7. Check the regulator setting using either a manometer or by clocking the gas meter. (See the applicable paragraphs in this instruction sheet.)
8. Install the new cap screw.
9. Mount conversion label on gas control.
10. Install gas control and appliance according to appliance manufacturer instructions.



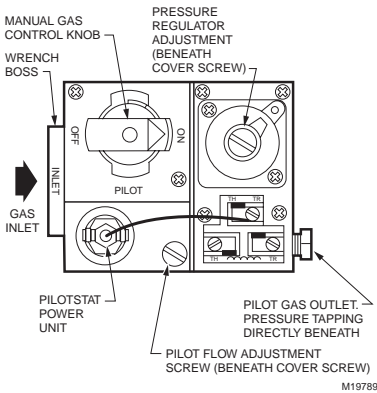

Fig. 1. Top view of standard capacity combination gas control.

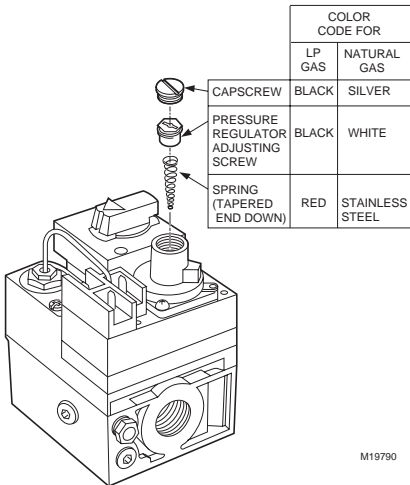

Fig. 2. Conversion kit installation.

Perform Gas Leak Test

⚠️ WARNING

Fire or Explosion Hazard.
Can cause severe injury, death or property damage.
 Check for gas leaks with soap and water solution any time work is done on a gas system.

Gas Leak Test

1. Paint pipe connections upstream of gas control with rich soap and water solution. Bubbles indicate gas leak.
2. If gas leak is detected, tighten all pipe connections.
3. Stand clear of main burner while lighting to prevent injury caused from hidden leaks which could cause flashback in the appliance vestibule. Light main burner.
4. With main burner operating, paint pipe joints (including adapters) and control inlet and outlet with rich soap and water solution.
5. If another gas leak is detected, tighten adapter screws, joints, and pipe connections.
6. Replace part if gas leak cannot be stopped.

Light Pilot (Standing Pilot Models)

1. Turn gas control knob clockwise ↻ to **OFF**. Wait five minutes to dissipate any unburned gas. Sniff around the appliance near the floor. Do not relight pilot flame if you smell gas.
2. Turn gas control knob counterclockwise ↻ to **PILOT**. Push down and hold the knob while lighting the pilot flame.
3. Hold the gas control knob down about one minute, then release.
 - a. If pilot flame goes out, turn gas control knob clockwise ↻ to **OFF** and repeat steps 1 through 3.
 - b. If pilot flame remains lit, turn gas control knob counterclockwise ↻ to **ON**.

Turn on System (Intermittent and Direct Ignition Systems)

Rotate the gas control knob counterclockwise ↻ to **ON**.

Turn on Main Burner

Follow appliance manufacturer instructions or adjust thermostat setting to call for heat.

Adjust Pilot Flame

The pilot flame should envelop 3/8 to 1/2 in. (10 to 13 mm) of the thermocouple or igniter-sensor tip. See Fig. 3. To adjust pilot flame:

Remove pilot adjustment cover screw (see Fig. 1).

Turn inner adjustment screw clockwise ↻ to decrease or counterclockwise ↻ to increase pilot flame.

Always replace cover screw after adjustment and tighten firmly to ensure proper operation.

START-UP

Gas Control Knob Settings

1. **OFF**—Prevents pilot and main burner gas flow.
2. **PILOT**—On standing pilot controls only. Permits pilot burner gas flow when red knob is held down or thermocouple current is above power unit dropout value.
3. **ON**—Permits gas flow into gas control. Pilot burner gas is controlled as in the **PILOT** position for standing pilot and intermittent pilot systems. Main burner gas flow is controlled by thermostat and automatic valve operators.

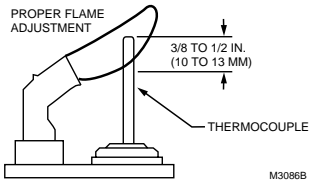

Fig. 3. Proper flame adjustment.

Check and Adjust Gas Input and Burner Ignition



CAUTION

Equipment Damage Hazard.

Exceeding ratings will damage the equipment.



- Do not exceed input rating stamped on appliance nameplate, or manufacturer recommended burner orifice pressure for size orifice(s) used. Make certain primary air supply to main burner is properly adjusted for complete combustion. Follow appliance manufacturer instructions.
- If checking gas input by clocking gas meter:
 - Make sure that the only gas flow through the meter is that of the appliance being tested.
 - Make sure that other appliances are turned off and their pilot flames are extinguished (or deduct their gas consumption from the meter reading).
 - Convert flow rate to Btuh as described in the Gas Control Handbook (form number 70-2602) and compare to Btuh input rating on appliance nameplate.
- If checking gas input with manometer:
 - Make sure gas control knob is in **PILOT** position before removing outlet pressure tap plug to connect manometer (pressure gauge).
 - Turn gas control knob back to **PILOT** when removing gauge and replacing plug.
 - Shut off gas supply at the appliance service valve or, for LP gas, at the gas tank before removing outlet pressure tap plug and before disconnecting manometer and replacing outlet pressure tap plug.
 - Perform Gas Leak Test at inlet pressure tap plug.

Checking Gas Pressure Using Meter Clocking Method



NOTE: Use this method when manometer is not available or when manifold pressure is not specified in inches wc (kPa) by the burner manufacturer.

- Make sure that the only gas flow through the meter is that of the appliance being tested.
- Make sure that other appliances are turned off and their pilot flames are extinguished (or deduct their gas consumption from the meter reading).

- Turn gas control knob to the **ON** position.
- To obtain an accurate outlet pressure reading, main burner must be cycled on and off several times to stabilize the pressure regulator diaphragm.
- Using a watch with a second hand, carefully clock the gas meter to determine the time per revolution. Use Table 1 to determine exact main burner gas flow rate in cubic feet per hour (cfh).
- Compare actual input with burner manufacturer recommended input (stamped on burner nameplate). To convert Btuh rating to cfh (m^3/hr), use the following formula:

$$\frac{\text{Input Rating in Btuh (MJ/hr)}}{\text{Btu Content of Gas per ft}^3 \text{ (MJ Content of Gas per M}^3\text{)}} = \text{Cfh (m}^3/\text{hr) or gas}$$
- If necessary, adjust pressure regulator to match appliance rating. (On step-opening regulators, match the full rate outlet pressure.)
 - Remove pressure regulator adjustment cap screw.
 - Using a screwdriver, turn inner adjustment screw clockwise  to increase or counterclockwise  to decrease gas pressure to main burner.
 - Always replace cap screw and tighten firmly to prevent gas leak.
- Turn gas supply to other appliances back on and relight all pilot flames according to appliance manufacturer instructions.
- Proceed to **CHECKOUT**.

Checking Gas Pressure Using a Manometer (Pressure Gauge)

- Turn gas control knob to **PILOT** (standing pilot systems) or **OFF** (intermittent and direct ignition systems).
- Remove outlet pressure tap plug from gas control and connect pressure gauge. See Fig. 1.
- Turn gas control knob to **ON** position.
- To obtain an accurate outlet pressure reading, main burner must be cycled on and off several times to stabilize the pressure regulator diaphragm.
- Light main burner and read pressure gauge.
- If necessary, adjust pressure regulator to match appliance rating. (On step-opening regulators, match the full rate outlet pressure.)
 - Remove pressure regulator adjustment cap screw.
 - Using a screwdriver, turn inner adjustment screw clockwise  to increase or counterclockwise  to decrease gas pressure to main burner.
 - Always replace cap screw and tighten firmly to prevent gas leak.
- Turn gas control knob to **PILOT** (standing pilot system) or **OFF** (intermittent and direct ignition systems).
- Remove pressure gauge and replace outlet pressure tap plug and pressure regulator cap screw.
- Proceed to **CHECKOUT**.

Converting Gas Flow Rate (Table 1)

- For one ft^3 per revolution gas meter dials, use table directly.
- For $1/2 \text{ ft}^3$ per revolution gas meter dials:

- a. Determine time for two dial revolutions.
 b. Use Table directly.
3. For two ft³ per revolution gas meter dials:
 a. Determine time for one complete dial revolution.
 b. Divide time by two.
 c. Use Table directly.

Table 1. Converting Gas Flow.

Time (sec)	Flow (cfh)	Flow (m3/hr)
40	90	2.55
41	88	2.50
42	86	2.44
43	84	2.38
44	82	2.32
45	80	2.27
46	78	2.21
47	77	2.18
48	75	2.12
49	73	2.07
50	72	2.04
51	71	2.01
52	69	1.95
53	68	1.93
54	67	1.90
55	65	1.84
56	64	1.81
57	63	1.78
58	62	1.76
59	61	1.73
60	60	1.70
62	58	1.64
64	56	1.59
66	54	1.53
68	53	1.50
70	51	1.44
72	50	1.42

Time (sec)	Flow (cfh)	Flow (m3/hr)
74	49	1.39
76	47	1.33
78	46	1.30
80	45	1.27
84	43	1.22
88	41	1.16
92	39	1.10
96	38	1.08
100	36	1.02
105	34	0.96
110	33	0.93
115	31	0.88
120	30	0.85
125	29	0.82
130	28	0.79
135	27	0.76
140	26	0.74
150	24	0.68
160	23	0.65
170	21	0.59
180	20	0.57

CHECKOUT

1. Make sure primary air supply is properly adjusted for complete combustion at final pressure regulator setting. Main burner must light reliably under all conditions.
2. Place system in operation and observe through at least one complete cycle to make sure all controls are operating properly.
3. If manometer (pressure gauge) method is used, perform Gas Leak Test at outlet pressure tap plug.
4. Label the gas control, heating appliance, and any other controls to show they have been converted to a new type of gas.

Honeywell

Automation and Control Solutions

Honeywell International Inc.
 1985 Douglas Drive North
 Golden Valley, MN 55422

Honeywell Limited-Honeywell Limitée
 35 Dynamic Drive
 Scarborough, Ontario
 M1V 4Z9

