

## C7005A,B Gas Pilot and Flame Rod Assemblies

### PRODUCT DATA

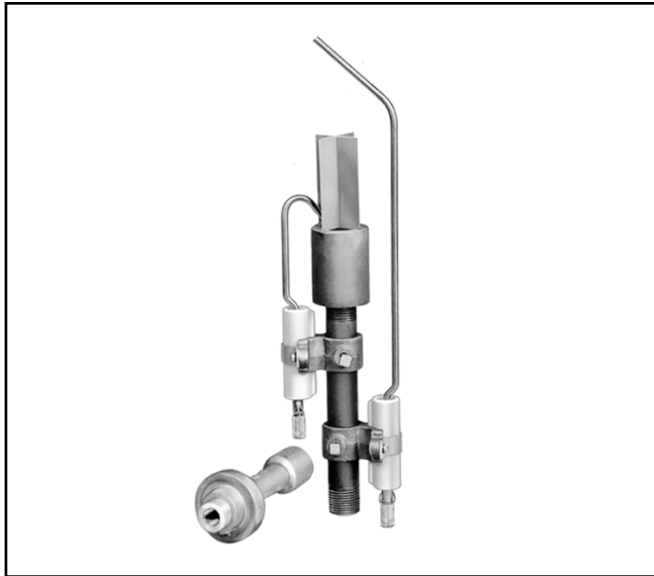

### GENERAL

The C7005A,B Gas Pilot Burner Assemblies include a flame rod to prove the pilot flame. The assemblies are used with a suitable flame safeguard control on industrial or commercial gas burners or oil burners with gas pilots.

### FEATURES

- Used with Honeywell controls using the flame rectification principle.
- C7005A is for continuous pilot applications. It includes an insulated flame rod, properly positioned relative to the flame retention type nozzle.
- C7005B is similar to C7005A, but includes an ignition electrode suitable for automatic, electric-spark ignition, gas pilot applications.
- Individually mounted flame rod and ignition electrode in ceramic insulators allow the head assembly to fit inside a 3-inch pipe.
- Stainless steel fins on the flame retention type pilot head provide the correct ratio of flame rod area to ground area for maximum flame signal, and are beneficial in stabilizing the pilot flame.
- Pilot flame retention nozzle and mixing tube are threaded internally, 1/2-14 NPT and 3/8-18 NPT, respectively, and can be assembled with standard pipe fittings.
- Pilot can be installed in vertical, horizontal, or inclined position.
- Rajah connectors facilitate electrical connections.

### Contents

General .....	1
Features .....	1
Specifications .....	2
Ordering Information .....	2
Installation .....	3
Adjustments and Checkout .....	5
Operation .....	8



## SPECIFICATIONS

### IMPORTANT

*The specifications given in this publication do not include normal manufacturing tolerances. Therefore, this unit may not exactly match the listed specifications. Also, this product is tested and calibrated under closely controlled conditions, and some differences in performance can be expected if those conditions are changed.*

### Models:

- C7005A Gas Pilot and Flame Rod Assembly—for continuous pilot applications; includes flame rod only.
- C7005B Gas Pilot and Flame Rod Assembly—for automatic pilot applications; includes flame rod and ignition electrode.

### Pilot Head:

Flame retention type with stainless steel bomb type fins. Threaded onto 1/2 x 6 inch (152 mm) pipe nipple with 1/2-14 NPT external threads.

### Type of Gas:

Models available for use with natural and propane gases.

### Gas Capacity (Varies with Gas Pressure):

Gas Pressure in. wc	Capacity kPa	ft <sup>3</sup> /hr	m <sup>3</sup> /hr
3	0.75	12.0	0.34
4	0.99	13.7	0.39
5	1.24	15.3	0.43
6	1.49	16.8	0.48
7	1.74	18.2	0.52

### Flame Rod/Ignition Electrode Insulators:

Ceramic.

### Maximum Temperature at Flame Rod Insulator:

500°F (260°C).

### Flame Rod/Ignition Electrode Material:

Kanthal A-1 (2462°F [1350°C] maximum operating temperature rating).

Optional: Stainless steel (2000°F [1093°C] maximum operating temperature rating).

### Electrical Connectors:

Rajah, male; companion connectors included.

### Insulator Brackets:

Adjustable to change location of flame rod or ignition electrode; lock securely using setscrew.

### Mixing Tube:

Inspirating (Venturi type) with primary air adjustment. Approximately 4-9/16 inches (116 mm) long, 1-3/4 inches (44.5 mm) diameter. Inlet tapping 1/4-18 NPT; outlet tapping 3/8-18 NPT.

### Mounting:

Vertical, horizontal, or inclined.

### Dimensions:

Overall—Height 13-1/2 inches (343 mm); width can be adjusted to pass through a 3-inch pipe.

Pilot Head—Length 4-7/16 inches (113 mm), diameter 1-5/8 inches (41.3 mm).

Spark Gap (C7005B only)—1/8 to 3/16 inch (3.2 to 4.8 mm).

### Approvals:

Underwriters Laboratories Inc. Listed: File No. MP268.  
Canadian Standards Association Certified: C7005 only—  
Master file LR-95329—1.  
Industrial Risk Insurers acceptable.

### Accessories:

- High Temperature Cable (for operation above 125°F [52°C])—specify length:
  - R1298020 Flame Rod Leadwire, rated up to 400°F (204°C) for continuous duty.
  - R1061012 Ignition Leadwire, rated at 350°F (176°C) for continuous duty.
  - R1239001 High Tension Ignition Leadwire, for installations in a contaminating environment, rated at 200°F (93°C) for continuous duty.

## ORDERING INFORMATION

When purchasing replacement and modernization products from your Authorized Flame Safeguard Distributor, refer to the TRADELINE® Catalog or price sheets for complete ordering number.

1. Order number.
2. High temperature cable, if required (specify length).
3. Ignition transformer, if required (C7005B only).

If you have additional questions, need further information, or would like to comment on our products or services, please write or phone:

1. Your local Home and Building Control Sales Office (check white pages of your phone directory).
2. Home and Building Control Customer Relations  
Honeywell, 1885 Douglas Drive North  
Minneapolis, Minnesota 55422-4386

In Canada—Honeywell Limited/Honeywell Limitee, 35 Dynamic Drive, Scarborough, Ontario M1V 4Z9 International Sales and Service Offices in all principal cities of the world. Manufacturing in Australia, Canada, Finland, France, Germany, Japan, Mexico, Netherlands, Spain, Taiwan, United Kingdom, U.S.A.

- Ignition Transformer, 6000 volts secondary (C7005B only):
  - Part no. 22042; 120V, 60 Hz primary.
  - Part no. 101079; 240V, 60 Hz primary.

**Replacement Parts:**

- 100204B Mixing Tube (Venturi type used with natural gas).
- 101867B Mixing Tube (Venturi type used with LP gas).
- 100205B Grounding Assembly
- 101738A Ignition Assembly—includes electrode, Rajah connector and bracket (C7005B).
- 101738B Flame Rod Assembly.
- 101739 Ignition Electrode, 4 inch (102 mm), stainless steel (C7005B).
- 101740 Flame Rod, 8 inch (203 mm) stainless steel.
- 103534 Flame Rod, 8 inch (203 mm) Kanthal.
- 101741 Connector—Rajah, plug end, 7/8 inch long.
- 101742 Clamp—for flame rod or ignition electrode mounting.
- 101743 Bracket—mounting.
- 14182 Washer—brass (plain), between Rajah connector and flame rod or ignition electrode mounting.
- 37356 Connector—Rajah, socket end straight.
- 7617CV Insulator Assembly—includes electrode insulator and mounting hardware.

Install the pilot so the pilot flame has full contact with the gas stream from the main burner heads, jets or nozzles (Fig. 3, 4, 5). If it is necessary to prove both pilot and main flames, mount the pilot so the flame travels in the same direction as the air movement at the mounting point, rather than where the air movement is at right angles to the flame travel. The pilot should be mounted far enough forward so that the flame rod just enters the envelope of the main burner flame. The pilot can be mounted either beside or below the burner head.

Keep the pilot burner below or behind the main burner so that the burner frame and refractory help protect the pilot from radiant heat. Locating the pilot in the secondary airstream also provides considerable cooling. The primary air adjustment must be accessible and outside the high temperature area.

On radiant type burners, the pilot is often mounted outside the burner box. Fig. 3 shows the pilot assembly in a diagonal channel cut through the brickwork and a straight-through connection used to support the pilot. The flame rod is at the junction of the main burner flame and pilot flame. The pilot assembly can be mounted below or alongside the burner box and an angle connection used so the pilot flame travels into the main flame. The air mixer is normally mounted outside the boiler.

**INSTALLATION**

**CAUTION**

1. Installer must be a trained, experienced, flame safeguard control service technician.
2. Turn off the gas supply before beginning installation.
3. Disconnect power supply to the flame safeguard control before beginning installation to prevent electrical shock and equipment damage. There may be more than one disconnect involved.
4. All wiring must comply with applicable local electrical codes, ordinances, and regulations.
5. All wiring must be NEC Class 1 (line voltage).
6. Perform all required checkout tests after installation is complete.

**Mounting**

If special provisions for mounting the pilot were made by the burner manufacturer, carefully follow those instructions. If the manufacturer did not supply instructions, use the recommendations below.

Fig. 1 illustrates the use of a 90 degree reducing elbow (not furnished) to provide a right-angle connection. Use a straight reducing coupling or a 45 degree reducing elbow (not furnished) for piping and mounting if more convenient.

Position the flame rod so that a weak pilot flame contacts the flame rod only at the junction of the main burner flame and pilot flame. *Do not position the flame rod so it can detect a weak pilot flame that is incapable of igniting the main burner* (Fig. 2).

**IMPORTANT**

To assure an adequate pilot flame to ignite the main burner, you **MUST** perform the pilot turndown test, as described in the instructions for the flame safeguard control.

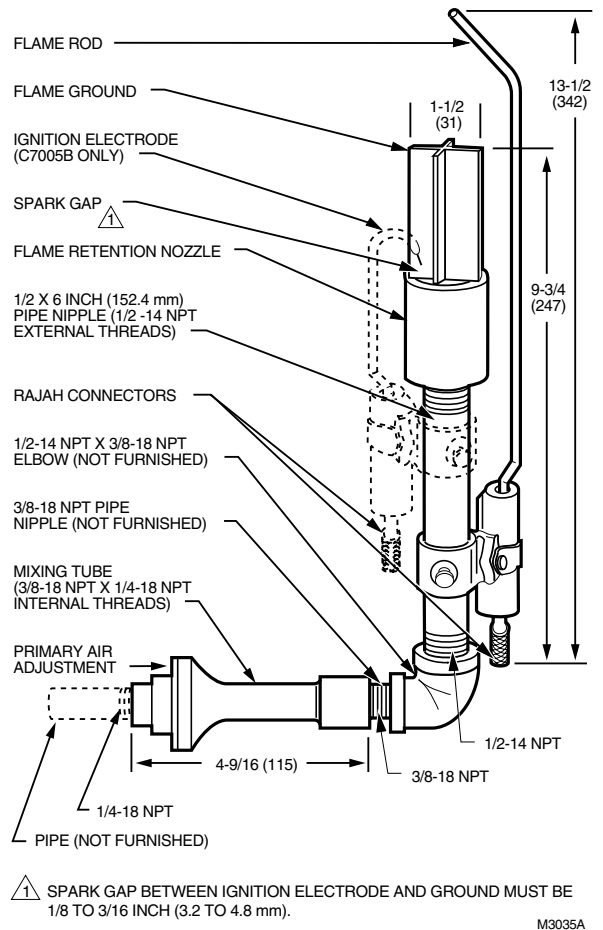

**Fig. 1. C7005 gas pilot and flame rod assembly in in. (mm).**

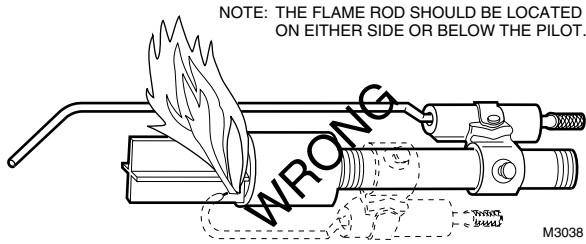

Fig. 2. Improper position of flame rod.

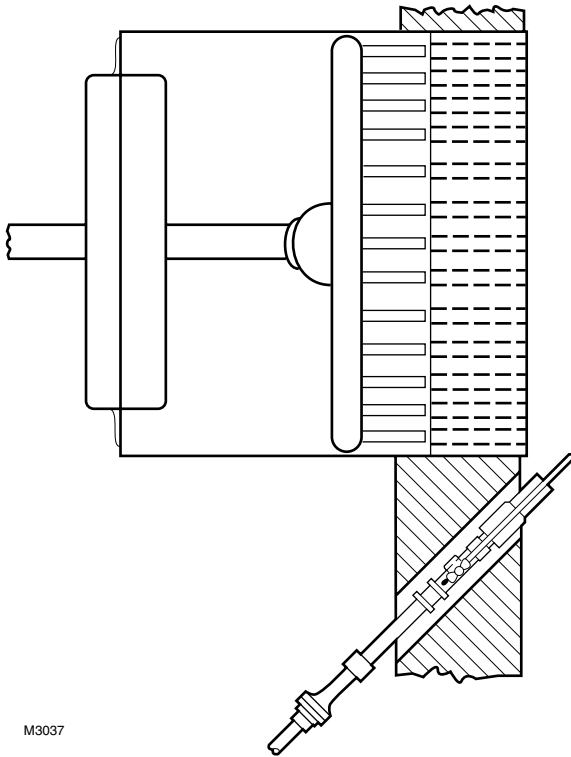

Fig. 3. Typical mounting of gas pilot and flame rod assembly on radiant inshot type burner.

On multiple head installations (Fig. 4), the pilot is usually centrally located. The pilot can usually be mounted vertically between burner heads with the pilot flame traveling upward across the junction of the gas stream from the burner heads. If the pilot is mounted horizontally on a level with the burner heads or the flat arch, the pilot flame should travel across the junction of the gas streams coming from at least two heads.

If a group of inspirating (Venturi type) burners are mounted within a burner box, sufficient spacing is usually available so the pilot can be mounted as illustrated in Fig. 5 to simultaneously light as many burners as possible. If available space does not allow central mounting within the burner box, see Fig. 3.

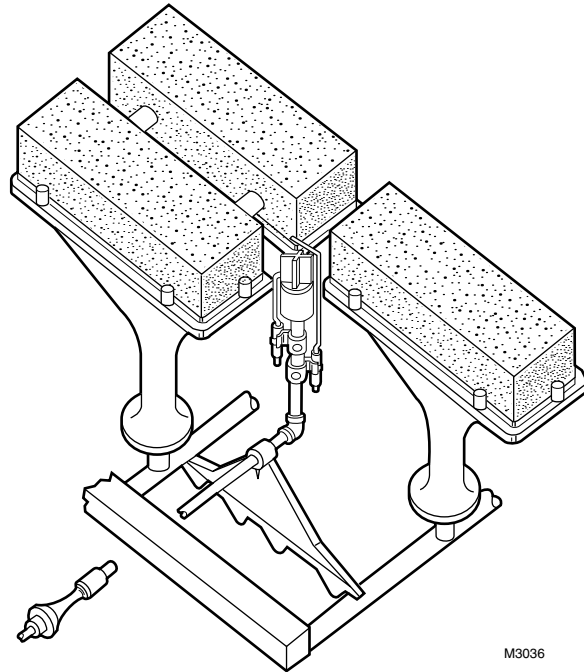

Fig. 4. Typical mounting of gas pilot and flame rod assembly on multiple head gas burner.

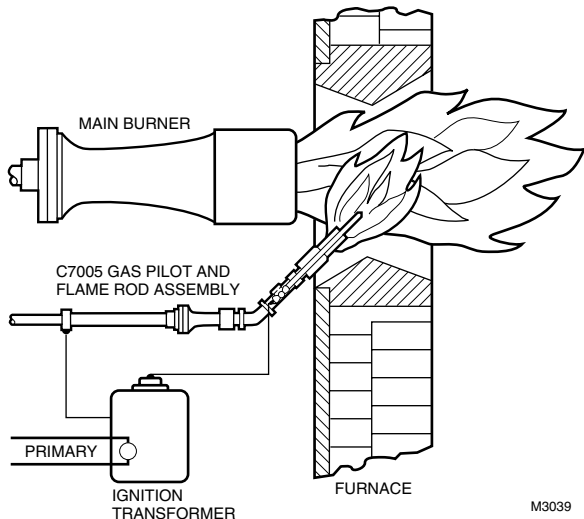

Fig. 5. Typical mounting of gas pilot and flame rod assembly on inspirating (Venture type) gas burner.

## Wiring

### ⚠ CAUTION

1. Turn off gas supply before starting installation.
2. Disconnect power supply before beginning installation to prevent electrical shock and equipment damage. There may be more than one disconnect involved.

All wiring must comply with applicable electrical codes, ordinances, and regulations. Use NEC Class 1 (Line Voltage) wiring.

For normal installations:

- For the ignition electrode, use high tension wire electrically equivalent to type GTO-10, and rated for the temperature and humidity encountered in the application.
- For the flame rod, use moisture-resistant no. 14 AWG wire suitable for at least 167°F (75°C) if used with a flame safeguard primary control, or suitable for at least 194°F (90°C) if used with a flame safeguard programming control.

For high temperature installations:

- For the ignition electrode, use Honeywell specification no. R1061012 Ignition Cable or equivalent. (This wire is rated at 350°F (176°C) for continuous duty, and up to 500°F (260°C) for intermittent use. It has been breakdown tested to 15,000 volts.)
- For the flame rod, use Honeywell specification no. R1298020 or equivalent. This wire is rated up to 400°F (204°C) for continuous duty. It is tested for operation up to 600 volts and breakdown up to 7500 volts.

For ignition installations in a contaminating environment, use Honeywell specification no. R1239001 High Tension Ignition Cable or equivalent. This wire is very resistant to severe conditions of oil, heat, and corona, and is tested to withstand high voltages up to 25,000 Vrms in a salt bath for one minute without breakdown. It is rated at 200°F (93°C) for continuous duty, and up to 350°F (176°C) for intermittent use.

Make connections to the flame rod and ignition electrode (C7005B) using Rajah connectors. See Fig. 6 for typical field wiring connections.

Connect the flame rod (see callout 1, Fig. 1) to the F terminal of the flame safeguard control. Keep this leadwire as short as possible; capacitance increases with leadwire length, reducing the flame signal strength. *The ultimate limiting factor is the flame signal* (see Table 1).

For a C7005B:

- Use a 6000 volt ignition transformer with the same electrical ratings as the power supply of the flame safeguard control. Select the appropriate Honeywell transformer, or its equivalent.
  - For 120V, 60 Hz, use part no. 22042.
  - For 240V, 60 Hz, use part no. 101079.
- Connect the primary leadwires of the ignition transformer between the ignition and the L2 terminals of the flame safeguard control.
- Connect the ignition electrode of the C7005B (callout 3, Fig. 1) to the secondary high tension terminal of the ignition transformer.

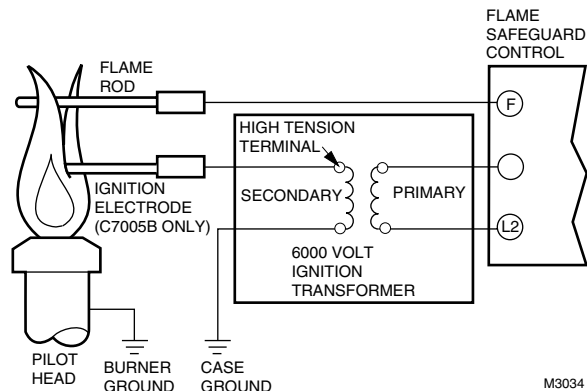

Fig. 6. Typical field wiring diagram for C7005 gas pilot and flame rod assembly.

#### IMPORTANT

Do not run high voltage ignition transformer wires in the same conduit with the flame rod wiring.

No ground leadwires are required. The flame ground and flame retention nozzle (callouts 2 and 4, Fig. 1) act as the ground electrode for the flame rod and the ignition electrode. The case of the ignition transformer will act as the ground connection when it is securely fastened to the burner.

## ADJUSTMENTS AND CHECKOUT

### Adjust the Air-Gas Mixture

#### IMPORTANT

For initial burner lightoff, consult the burner manufacturer's instructions or the instructions for the flame safeguard control.

With the gas pilot installed and the pilot burner running, adjust the primary air adjustment (callout 10, Fig. 1) for an air-gas mixture that provides the type of flame required for the particular installation. Be sure you have the proper mixing tube for the type of gas (natural or LP) being used. A medium-hard flame generates the greatest response from the flame detector circuit.

If air movement conditions are severe or change with modulation, it may be desirable to operate the premixed pilot on moderate to high gas pressure (normally not more than one psi). This is particularly true when the main burner fires with high pressure gas. Increasing the pilot pressure tends to harden and lengthen the pilot flame, increasing its stability under adverse draft conditions.

## Adjust Flame Rod Position

The pilot flame must make good contact with the flame rod and furnish reliable ignition for the main burner. Check to be sure that the flame rod is located at the junction of the main burner flame and the pilot flame. Ensure that the main valve opens or unlocks only when the pilot flame is strong enough to ignite the main burner.

Secondary air velocity over the pilot nozzle must not cause unstable flame contact with the flame rod, because this produces chattering of the flame detector relay.

## Measure the Flame Signal

With the pilot and main burner(s) operating, adjust the position of the flame rod for optimum flame signal (current or voltage).

Most existing Honeywell flame safeguard controls incorporate a flame signal jack located on the control amplifier or on the control itself. These controls require a Honeywell W136A Test Meter (see Fig. 7) or its equivalent for measuring the flame signal in microamperes. The flame signal (current) is measured by the following procedure:

- 1 Use a Honeywell W136A Test Meter. (If a W136A is not available, a microammeter with a 0 to 25 microamp dc range can be used.)

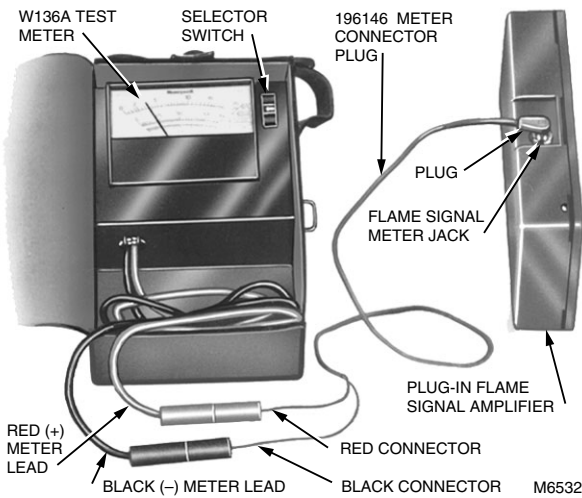

Fig. 7. Measuring microamp flame signal.

- 2 Set the selector switch on the test meter to 25 uA for all standard amplifiers and flame safeguard controls, or to SPL for an R7247B AMPLI-CHECK™ self-check rectification amplifier. (If the test meter is not a W136A, shunt the 0 to 25 microamp dc range with a 50 microfarad capacitor.)
- 3 Use a 196146 Meter Connector Plug (ordered separately). Connect the red spade tip to the red (+) meter lead and the black spade tip to the black (-) meter lead.

- 4 Insert the plug into the flame signal meter jack and allow a few seconds for the meter reading to stabilize.
- 5 When using a RA890H,J self-checking flame safeguard control, press the test button on the control to stabilize the current reading while making the measurement. The green flame indicating lamp should be on continuously while reading the flame signal.
- 6 Read the average *stable* current. For an R7247B self-check rectification amplifier (AMPLI-CHECK™), disregard the peaks due to self-checking operation. The red flame-indicating lamp on an R7247B should blink about 2-1/2 to 4 times a second (from bright to dim). If the lamp is on or off continuously while reading the flame signal, replace the amplifier.

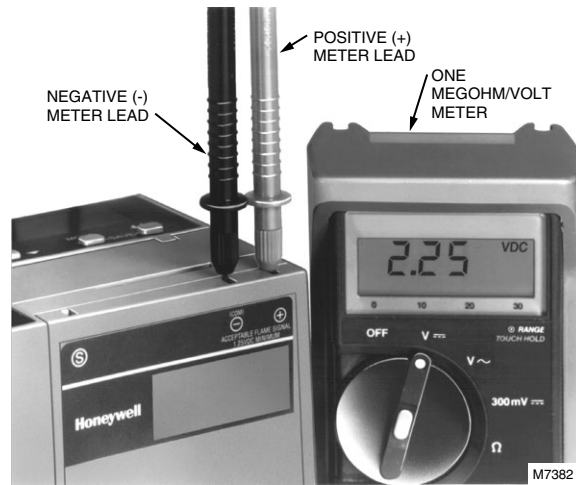

Fig. 8. Measuring flame signal voltage of 7800 SERIES control.

- 7 The meter reading must be as specified in Table 1 after all tests are completed and all adjustments are made.

With the Honeywell 7800 Series controls, the flame signal is measured in Vdc. The voltage flame signal measurement requires a volt-ohmmeter with a minimum sensitivity of one megohm/volt and a 0 to 5 or 10 Vdc scale. To make the flame signal measurement on 7800 SERIES controls, use the following procedure:

- 1 Set the meter to the appropriate scale.
- 2 Insert the positive (red) meter probe into the positive (+) jack of the 7800 SERIES control amplifier and the negative (black) probe into the negative (-Com) jack of the amplifier (see Fig. 8).
- 3 Allow a few seconds for the meter reading to stabilize.
- 4 When using an AMPLI-CHECK™ amplifier, read the average stable voltage and disregard the peaks due to the self-check operation.
- 5 The flame signal voltage must be at least the minimum acceptable voltage as indicated in Table 1.
- 6 If the 7800 SERIES control has the optional Keyboard Display Module, the flame signal will be displayed on the module.

Table 1. Flame Signal For C7005A,B.

Flame Signal Amplifier	Flame Safeguard Control	Minimum Acceptable Steady Current (uA)	Maximum Expected Current (uA)	Minimum Acceptable Steady voltage (Vdc)	Maximum Expected Steady voltage (Vdc)
R7247A	BC7000L; R4140G,L,M; R4138C,D; R4075C,D,E	2.0	5.0		
R7247B <sup>a</sup> AMPLI-CHECK™	BC7000L; R4140G,L,M; R4138C,D; R4075C,D,E	1.25	2.50		
R7257A	R4150	2.0	5.0		
R7289A	R4795	2.0	5.0		
R7847A	RM7800E,G,L,M; RM7838A,B; RM7840E,G,L,M; RM7885A; RM7890A,B; RM7895A,B,C,D			1.25	5.0
R7847B AMPLI-CHECK™	RM7800E,G,L,M; RM7838A,B; RM7840E,G,L,M; RM7885A; RM7890A,B; RM7895A,B,C,D			1.25	5.0
None	RA890F, R7795B,D,F,H; R7023B, R485	2.0	5.0		
None	R4181 <sup>b</sup>	8.0	15.0		

<sup>a</sup> Set W136A selector switch to SPL (damped) position to read current.

<sup>b</sup> Press test button while reading current.

Measure the flame signal for the pilot alone, the main burner flame alone, and both together (unless monitoring only the pilot flame when using an intermittent pilot, or only the main burner flame when using direct spark ignition). Also measure the flame signal at high and low firing rates and while modulating in between (as applicable). With the detector in its final position, all required flame signals must be steady (or stable) and as specified in Table 1.

If the signal is unstable or less than the minimum acceptable current, check the flame rod installation and circuitry:

- Check the supply voltage at terminals L1-L2 on the wiring subbase or terminal strip for the flame safeguard control.
- Check the wiring for defects including:
  - wrong type or size of wire.
  - deteriorated wire.
  - open circuits.
  - short circuits.
  - leakage paths caused by moisture, soot, or accumulated dirt.
- Make sure:
  - there is enough ground area.
  - the flame rod is properly located in the flame.
  - temperature at the flame rod insulator is no greater than 500°F (260°C).
  - ignition interference is not present (see Ignition Interference Test below).
- Make sure that the flame adjustment is not too lean.
- If necessary, reposition the flame rod.

If you cannot obtain proper operation, replace the plug-in amplifier if applicable. If you still cannot obtain proper operation, replace the flame rod.

## Pilot Turndown Test

If the flame rod is used to prove a pilot flame before the main fuel valve can be opened, perform a Pilot Turndown Test. Follow the Instruction procedures for the appropriate flame safeguard control, and the burner manufacturer's instructions.

## Ignition Interference Test

### C7005B

Test to make certain that a false signal from the spark ignition system is not superimposed on the flame signal.

Ignition interference can subtract from (decrease) or add to (increase) the flame signal. If it decreases the flame signal enough, it causes safety shutdown. (The flame relay will not pull in and the flame safeguard control will act as though the pilot or main burner, if using direct spark ignition, has not been ignited.) If it increases the flame signal, it could cause the flame relay to pull in when the true flame signal is below the minimum acceptable value.

### Test

Start the burner and measure the flame signal with both ignition and pilot or main burner on, and then with only the pilot or main burner on. Any significant difference greater than 0.5 microamp, or 0.25 Vdc with 7800 SERIES controls, indicates ignition interference.

### To Eliminate Ignition Interference

- ① Make sure there is enough ground area.
- ② Be sure the ignition electrode and the flame rod are on opposite sides of the ground area (Fig. 1).

- ③ Check for correct spacing between the ignition electrode and ground for 6000 volt systems—1/8 to 3/16 inch (3.2 to 4.8 mm).
- ④ Make sure the leadwires from the flame rod and ignition electrode are not too close together.
- ⑤ Replace any deteriorated leadwires.
- ⑥ If the problem cannot be eliminated, consider changing to an ultraviolet flame detection system with a Q624A1014 solid-state spark generator.

## Final Checkout

Before putting the burner into service, check out the installation by following the Checkout procedures in the Instructions for the appropriate flame safeguard control. After completing the checkout, run the burner through at least one complete cycle to verify operation.

## OPERATION

The C7005B Gas Pilot and Flame Rod Assembly includes an ignition electrode and a flame rod. The operation of these two electrodes in a simple electrically-operated, gas pilot installation is as follows.

At the beginning of the starting cycle, a high voltage from the secondary winding of the ignition transformer is applied to the ignition electrode. A spark jumps across the outlet of the pilot burner. The pilot gas valve is either automatically or manually opened, and the spark ignites the gas.

When the ignition transformer is energized, ac voltage is applied to the flame rod through a flame safeguard control. When the pilot flame appears, this ac voltage is changed to dc voltage through a rectifying action. This dc voltage then operates a relay, opening the valve to the main burner (or permitting it to be manually opened). In the event of flame failure, flame rectification stops, the gas valves are de-energized, the valves close, and the system shuts down.

---

**Honeywell**

**Home and Building Control**

Honeywell Inc.  
1985 Douglas Drive North  
Golden Valley, MN 55422

**Home and Building Control**

Honeywell Limited-Honeywell Limitée  
740 Ellesmere Road  
Scarborough, Ontario  
M1P 2V9

*Helping You Control Your World*



QUALITY IS KEY