

V48A,F,J; V88A,J Diaphragm Gas Valves

PRODUCT DATA



APPLICATION

The V48 and V88 are solenoid-operated diaphragm valves suitable for LP (Liquefied Petroleum), natural, and manufactured gases. They are normally used on atmospheric boilers, commercial water heaters, and rooftop heaters.

FEATURES

- Line voltage, 2-wire thermostat or controller used with a V48; V88 used with 24V thermostat.
- Valves provide slow opening and fast closing.
- Two second maximum closing time.
- V48J, V88J rated for 150°F (66°C) ambient temperature.
- V48F rated for 5 psi (lb. per sq. in.) (34.5 kPa). V48A and V88A rated for either 1/2 or 1 psi (3.4 or 6.9 kPa), depending on model. V48J and V88J rated for 1 psi (6.9 kPa).
- One model for natural and LP gases.
- Wide range of sizes and capacities.
- Firm closing; diaphragm is both weight and spring loaded.
- Valve closes on power failure; recommended for final shutoff service.
- Adjustable or fixed bleed orifices available for installation by OEM.
- Valve position indicator on 1-1/4 in. V48A2227 and 2 in. V48F1103 Valves.

Contents

Application	1
Features	1
Specifications	2
Ordering Information	2
Installation	4
Wiring	6
Operation	8
Checkout and Troubleshooting	9
Service Information	10



SPECIFICATIONS

Models:

V48A (120 Vac) or V88A (24 Vac) solenoid operated diaphragm valves for 1/2 or 1 psi (3.4 or 6.9 kPa) maximum operating pressure.

V48F (120 Vac) solenoid operated diaphragm valve for 5 psi (34.5 kPa) maximum operating pressure.

V48J (120 Vac) or V88J (24 Vac) solenoid operated diaphragm valves for 1 psi (6.9 kPa) operating pressure and 150°F maximum ambient temperature.

Type of Gas: Suitable for liquefied petroleum (LP), natural, manufactured, and sulfur-bearing gases.

Valve Capacity: See table in Fig. 2.

Valve Pattern: Straight-through, non-offset.

Valve Body Material: Die-cast aluminum.

Pilot Tapping (see Table 1 for thread type):

3/4 through 1-1/2 inch valves: 1/8-27 NPT or 1/8-28 BSP.PI.
2 through 3 inch valves: 1/4-18 NPT.

Bleed Tapping (see Table 2 for thread type): 1/8-27 NPT or 1/8-28 BSP.PI.

Valve Opening Time:

Five seconds maximum at 2 oz/in.² (0.86 kPa) pressure.
Adjustable bleed valve assembly or fixed bleed orifices available for longer opening time (NPT threads only; see Accessories).

Valve Closing Time (on power failure; measured at 2 oz/in.² [0.86 kPa] pressure): 2 seconds maximum.

Maximum Operating Pressure: See Table 2.

Power Consumption (maximum): 9 watts or 15 VA.

Ambient Temperature Rating:

V48A,F and V88A: 32°F to 125°F (0°C to 52°C).
V48J and V88J: 32°F to 150°F (0°C to 66°C).

Maximum Fluid Temperature:

V48A,F; V88A: 125°F (52°C).
V48J; V88J: 150°F (66°C).

Thermostat Heat Anticipator Setting: For 60 Hz V88, set at 0.6A.

Dimensions: See Fig. 1.

Weight: See Table 1.

Table 1. Valve Weight.

Pipe Size (in.)	lb	kg
3/4	2-1/2	1.13
1	3	1.36
1-1/4	3-1/2	1.59
1-1/2	4	1.81
2	9	4.08
2-1/2	8-1/2	3.86
3	9-1/2	4.31

Approvals: (60 Hz models only):

Underwriters Laboratories Inc. Listed: File No. MH1639;
Guide No. YIOZ.
CSA 158158-2500005576 (Z21.21-CSA 6.5).

NOTE: All models rated at 50 Hz and all models with BSP.PI threads are not CSA Design Certified.

Optional Feature: Valve position indicator is available on 1-1/4 in. V48A2227 and 2 in. V48F1103.

Replacement Coil Assemblies:^a

116930: 24V, 60 Hz V88A
116931: 120V, 60 Hz V48A.
116932: 220V, 50 Hz V48A
116932: 240V, 60 Hz V48A
118888: 24V, 60 Hz V88J
139937: 120V, 60 Hz V48J

^a These V48/V88 bonnet assemblies and solenoid operators are not compatible with old style valve bodies.

ORDERING INFORMATION

When purchasing replacement and modernization products from your TRADELINE® wholesaler or distributor, refer to the TRADELINE® Catalog or price sheets for complete ordering number.

If you have additional questions, need further information, or would like to comment on our products or services, please write or phone:

1. Your local Home and Building Control Sales Office (check white pages of your phone directory).
2. Home and Building Control Customer Relations
Honeywell, 1885 Douglas Drive North
Minneapolis, Minnesota 55422-4386

In Canada—Honeywell Limited/Honeywell Limitée, 35 Dynamic Drive, Scarborough, Ontario M1V 4Z9.

International Sales and Service Offices in all principal cities of the world. Manufacturing in Australia, Canada, Finland, France, Germany, Japan, Mexico, Netherlands, Spain, Taiwan, United Kingdom, U.S.A.

Table 2. Models Available.

Model	Voltage and Frequency	Maximum Operating Pressure		Pipe Size (in.)	Thread Type ^a
		psi	kPa		
V48A	100V, 50 Hz	1/2	3.4	1, 1-1/4, 1-1/2	BSP.PI
		1	6.9	2	
	120V, 60 Hz	1/2	3.4	3/4, 1, 1-1/4, 1-1/2	NPT
		1	6.9	1, 1-1/4, 1-1/2, 2, 2-1/2, 3	
V48F	220V, 50 Hz			1, 1-1/4, 1-1/2, 2, 3	BSP.PI
	240V, 50 Hz			2	NPT
V48J	120V, 60 Hz	1	6.9	3/4, 1, 1-1/4, 1-1/2, 2	
	110V, 50 Hz				
V88A	24V, 60 Hz	1/2	3.4	3/4, 1, 1-1/4, 1-1/2	
		1	6.9	3/4, 1, 1-1/4, 1-1/2, 2, 2-1/2, 3	
V88J	24V, 60 Hz		6.9	1, 1-1/4	

^a A valve position indicator is on 1-1/4 in. V48A2227 and 2 in. V48F1103 Valves. BSP.PI—British Standard Parallel Internal Threads; NPT—American Standard Taper Pipe Threads.

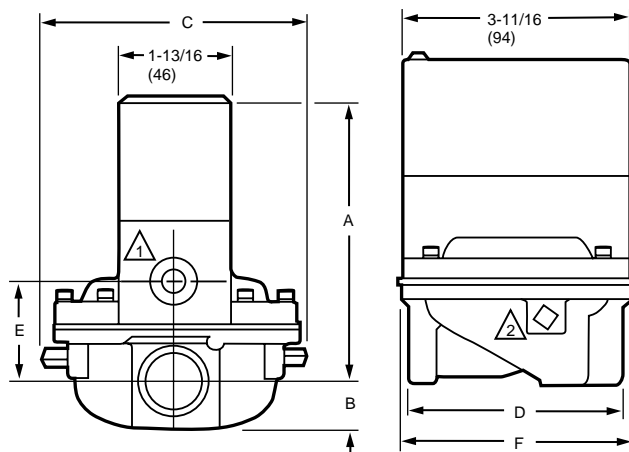

VALVE SIZE (IN.)	APPROXIMATE DIMENSIONS											
	A		B		C		D		E		F	
	IN.	MM	IN.	MM	IN.	MM	IN.	MM	IN.	MM	IN.	MM
3/4	4-11/16	119.1	3/4	19.1	4-5/8	117.5	3-1/2	88.9	1-5/8	41.3	3-13/16	96.8
1	5-1/16	128.6	1	25.4	5	127.0	3-11/16	93.7	2-1/16	52.4	4-5/16	109.5
1-1/4	5-9/16	141.3	1-1/4	31.8	5-7/8	149.2	5-5/16	134.9	2-3/8	60.3	5-5/16	134.9
1-1/2	5-9/16	141.3	1-1/4	31.8	5-7/8	149.2	5-5/16	134.9	2-3/8	60.3	5-5/16	134.9
2	6-15/16	176.2	2-1/4	57.2	9-1/2	241.3	8-3/8	212.7	3-9/16	90.5	5-5/16	236.5
2-1/2	6-15/16	176.2	2-1/4	57.2	9-1/2	241.3	8-3/8	212.7	3-9/16	90.5	9-5/16	236.5
3	6-15/16	176.2	2-1/4	57.2	9-1/2	241.3	8-3/8	212.7	3-9/16	90.5	9-5/16	236.5

1 BLEED TAPPING: 1/8-27 NPT, OR 1/8-28 BSP. PL.

2 PILOT TAPPING (2): 1/8-27 NPT FOR 3/4 THROUGH 1-1/2 IN. SIZES, 1/4-18 NPT FOR 2 THROUGH 3 IN. SIZES; OR 1/8-28 BSP. PL FOR 1 THROUGH 1-1/2 IN. SIZES, 1/4-19 BSP.PL FOR 2 THROUGH 3 IN SIZES.

M8487

Fig. 1. Mounting dimensions of V48A,F,J and V88A,J Diaphragm Gas Valves in in. (mm).

Table 3. Extending Valve Opening Time^a By Adding a Bleed Orifice.

Valve Size (in.)	Valve Opening Time (seconds)		
	No Orifice	Orifice No. 122160, 0.018 in. (0.46 mm)	Orifice No. 124674, 0.011 in. (0.28 mm)
1	1	2	3
1-1/4	1	5	6
1-1/2	1	5	6
2	4	15	32
2-1/2	4	23	37
3	5	24	37

^a Time to reach 80% gas flow at fully open position. Inlet pressure; 4.2 in. wc (1.05 kPa) for 1 to 2 in. valves; 5 in. wc (1.25 kPa) for 2-1/2 and 3 in. valves. Pressure drop across valves at fully open position. 0.2 in. wc (0.05 kPa) for 1 to 2 in. valves; 1 in. wc (0.25 kPa) for 2-1/2 and 3 in. valves.

Accessories:

Transformer AT72D: (40 VA) for all V88 models.
 126590 Adjustable Bleed Valve Assembly: Consists of adjustable bleed valve with sleeve and compression nut for connecting to 1/4 in. tubing; see Fig. 8.
 Bleed Orifice: Fixed (see Table 2 for appropriate size):
 124674 Orifice: 0.011 in. (0.28 mm) diameter.
 122160 Orifice: 0.018 in. (0.46 mm) diameter.

Gas Valve Sizing

1. Check the burner nameplate for (a) the type of gas used, and (b) the gas flow capacity. The capacity will be listed in Btu/h (Btu per hour) or in cf/h (cubic feet per hour).
2. Call the gas utility for information on (a) the specific gravity (sp gr) and (b) Btu per cubic feet (Btu/cu ft) for type of gas used.
3. Find the capacity in cf/h. If the capacity is listed in Btu/h, convert to cf/h by the following formula.
 Capacity in cf/h = $\frac{\text{Btu/h (from burner nameplate)}}{\text{Btu/cu ft (from gas utility)}}$
4. For gases with specific gravities other than 0.64, multiply the burner cf/h by the conversion factor in Table 4.
5. Use the corrected burner capacity in cf/h when determining the gas valve size in Fig. 2.
6. Determine the maximum pressure drop across the valve, and draw a horizontal line at this pressure in Fig. 2.

Table 4. Conversion Factors.

Type of Gas	Average Specific Gravity	Divide cfh by:
Manufactured	0.60	.968
Mixed	0.70	1.046
LP—Propane	1.53	1.546
LP—Butane	1.98	1.759

7. Draw a vertical line in Fig. 2 at the capacity (cf/h) previously determined. Use the corrected capacity for a gas with a specific gravity other than 0.64.
8. Use the valve size at the intersection of the horizontal and vertical lines. If the intersection is between valve sizes, use the next higher valve size to the right.

To Size Two Identical Valves Piped in Series

1. Find the cf/h for the type of gas used.
2. Consider both valves as one unit. Determine the total maximum pressure drop across the unit.
3. Find the pressure drop across the first valve by assuming it to be 45 percent of the total pressure drop.
4. Find the valve size from Fig. 2.

5. The second valve will be the same size as the first valve.

INSTALLATION

When Installing This Product...

1. Read these instructions carefully. Failure to follow them could damage the product or cause a hazardous condition.
2. Check the ratings given in the instructions and on the product to make sure the product is suitable for your application.
3. Installer must be a trained, experienced, flame safeguard control technician.
4. After installation is complete, check out product operation as provided in these instructions.

⚠ WARNING

Explosion or Electrical Shock Hazard. Can cause severe injury, death or property damage.

1. Turn off gas supply before starting installation.
2. Disconnect power supply before beginning installation to prevent electrical shock and equipment damage.
3. Do not remove seal over valve inlet or outlet until ready to connect piping.
4. Do not bend tubing at the valve after the compression nut is tightened because this may result in gas leakage at the connection.
5. Install valve in a horizontal pipe line in any upright position with the gas flow in the direction indicated by the arrow on the casting.

Prepare Piping and Install Valve (Fig. 3)

1. Use new, properly reamed pipe free from chips.
2. Do not thread pipe too far. Valve distortion or malfunction may result from excess pipe in valve.
3. Apply good quality pipe dope, putting a moderate amount on the male threads only. If pipe dope lodges on the valve seat, it will prevent proper closure. If using liquefied petroleum (LP) gas, use pipe dope resistant to action of LP gas.
4. Install valve in a horizontal pipe line in an upright position with the gas flow in the direction indicated by the arrow on the casting.
5. Apply a parallel jaw wrench only to the flat next to the pipe being inserted. A wrench applied to the valve body itself or to the end farthest from the pipe being inserted may distort the casting, causing a malfunction.
6. The gas flow MUST be in the same direction as the arrow on the bottom of the valve body.

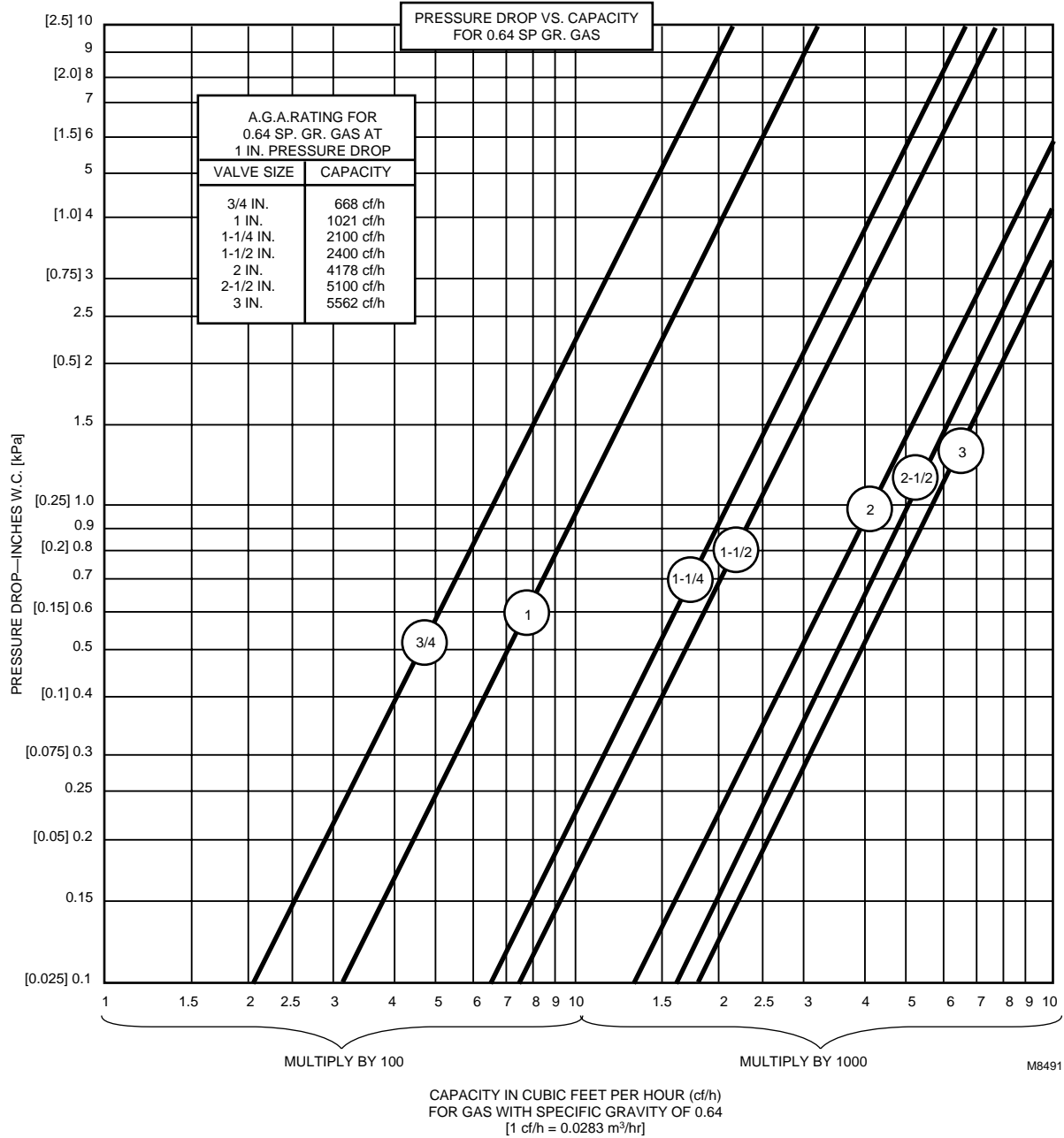

Fig. 2. Pressure drop vs. capacity chart for sizing gas valves.

⚠ WARNING

Explosion or Fire Hazard.
Can cause severe injury, death or property damage.
 If the flow is not in the same direction as the arrow on the bottom of the gas valve, the valve may not shut off, causing an accumulation of gas in the combustion chamber.

Connect Pilot and Bleed Gas Tubing (Fig. 4)

1. Square off and remove burrs from end of the tubing. Bend tubing to the desired form for routing to the pilot burner. Do not bend tubing at the valve after the compression nut is tightened because this may result in gas leakage at the connection.
2. Unscrew brass compression fitting from pilot gas tapping (Fig.4). Slip the fitting over the tubing and slide out of the way.

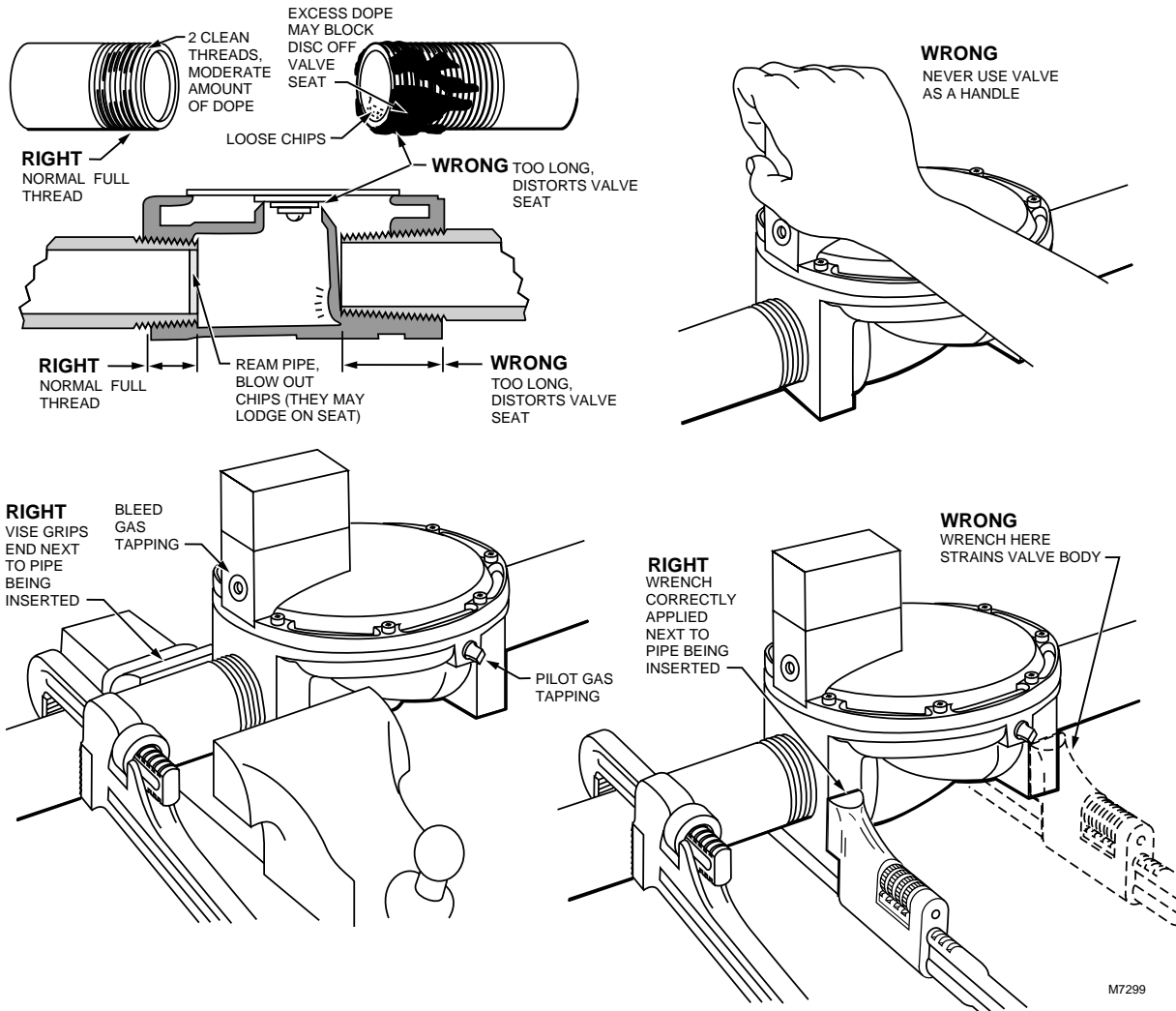

Fig. 3. Preparing piping and installing valve.

IMPORTANT:

When replacing a valve, cut off old compression fitting and replace with a new compression fitting. Never use the old compression fitting because it may not provide a tight gas seal.

3. Push tubing into the pilot gas tapping on the outlet end of the valve until it bottoms. While holding tubing all the way in, slide fitting into place and engage threads—turn until finger tight. Then use wrench and tighten one turn beyond finger tight.
4. Connect other end of tubing to pilot burner according to pilot burner manufacturers instructions.
5. If required, connect the tubing to bleed gas tapping (Fig. 3 and 4) as described in step 3. Connect other end of bleed tubing to main burner or to outside atmosphere.

WIRING

1. Disconnect the power supply before making wiring connections to prevent electrical shock and equipment damage.

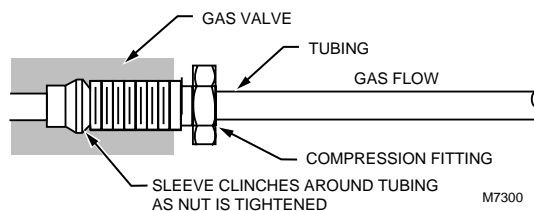

Fig. 4. Connecting tubing to pilot for bleed gas tapping.

2. All wiring must comply with applicable electrical codes, ordinances, and regulations. Use NEC Class 1 (line voltage) wiring.

3. For normal installations, use moisture-resistant No. 14 wire suitable for at least 167°F (75°C) if using a flame safeguard primary control, or for at least 194°F (90°C) if using a flame safeguard programming control.
4. For high temperature installation, use moisture-resistant No. 14 wire selected for a temperature rating above the maximum operating temperature.
5. Check the power supply circuit. The voltage and frequency must match those of the valve.
6. Refer to Fig. 5 or 6 for typical field wiring connections. Follow the burner manufacturers wiring diagram if provided.
7. Make wiring connections inside the actuator housing (Fig. 7):
 - a. Loosen the cover screw in the front of the actuator housing, and remove the housing cover.
 - b. If a conduit is required, run the conduit through the opening in the actuator housing, and run the external wires through the conduit.
 - c. Using solderless connectors, connect the external wires to the two 6 in. (152.4 mm) black leadwires (from the coil).
 - d. Locate the connections inside the actuator housing.
 - e. Replace the housing cover, and tighten the cover screw holding it to the actuator housing.
8. Recheck the wiring circuits before putting the valve into service.

connection. Then alternately energize and de-energize the valve actuator, and adjust the screw on the bleed valve for the desired valve opening time.

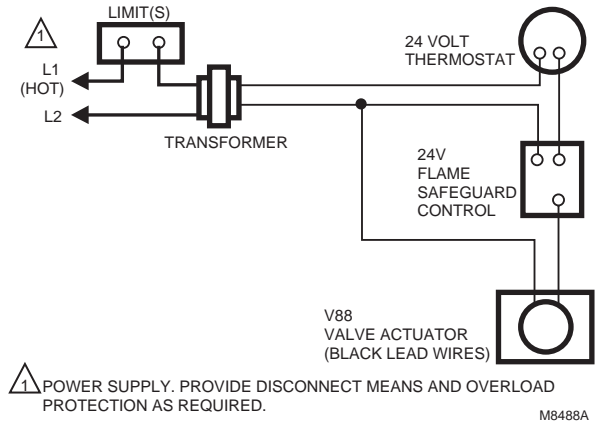

Fig. 6. Typical wiring diagram for V88.

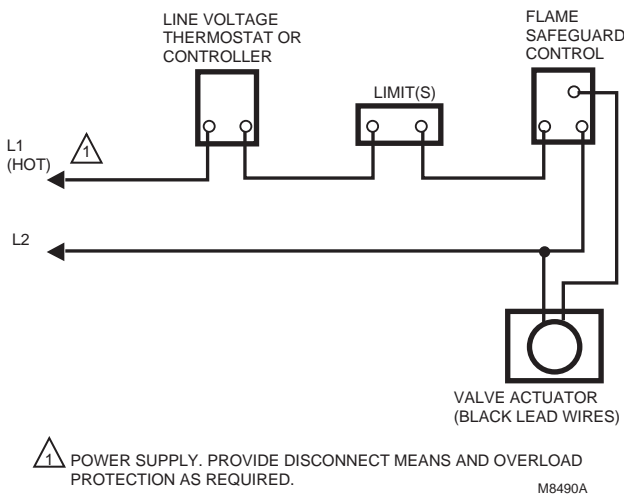

Fig. 5. Typical wiring diagram for V48.

Installation of an Optional Adjustable Bleed Valve (Fig. 8).

NOTE: This device is not available for valves with BSP.PI threads.

Screw the 126590 Adjustable Bleed Valve into the tapping marked BLEED. Be sure to screw the end with the 1/8-NPT threads into the BLEED tapping. Complete the bleed line

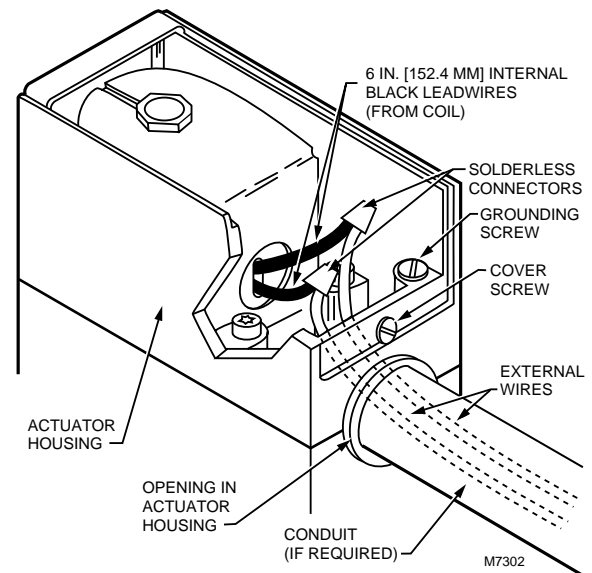

Fig. 7. Making wiring connections.

Installation of an Optional Bleed Orifice (Fig. 9)

NOTE: The orifice tool cannot be used on valves with BSP.PI threads.

Press the selected bleed orifice (see Table 2) over the 1/8 in. diameter dowel and press until the orifice cup bottoms in the bleed port. Complete the connection of the bleed tubing.

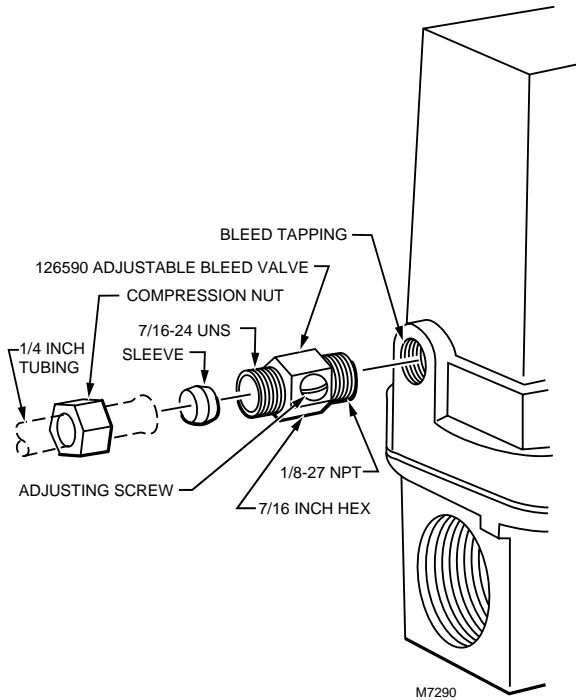

Fig. 8. Installing optional 126590 adjustable bleed valve.

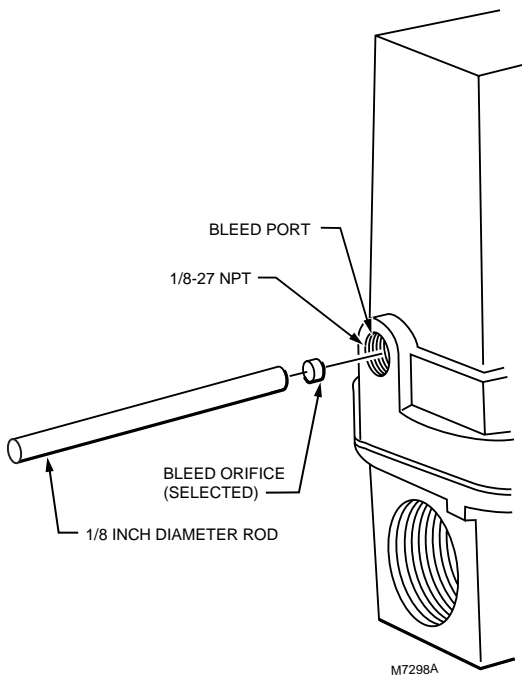

Fig. 9. Installing optional bleed orifice.

OPERATION

Operation of the V48 and V88 Valves (Fig. 10)

When the controller is not calling for heat, the coil is de-energized. The plunger in the 3-way actuator is in the DOWN position so the bleed port is closed and the supply port is open. Gas flows into the top part of the valve. The gas pressure on top of the diaphragm, the weight, and the spring hold the valve closed.

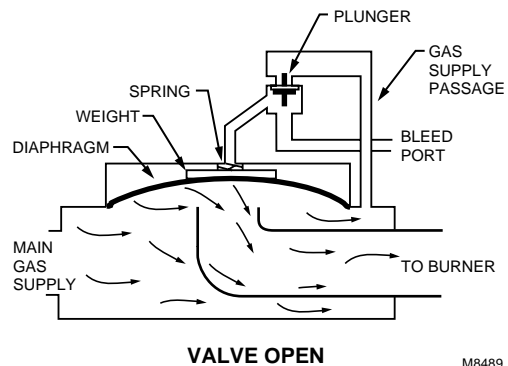
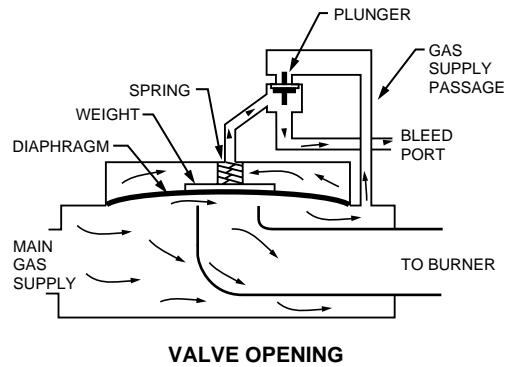
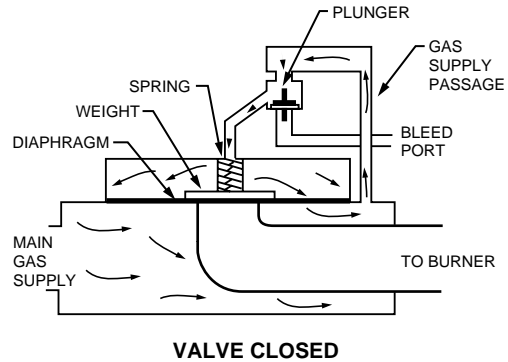

Fig. 10. Operation of V48 and V88 diaphragm gas valves.

On a call for heat, the controller contacts close and the coil is energized. This pulls the plunger to the UP position, opening the bleed port and closing the supply port. The gas in the top

of the valve flows out through the bleed port. This reduces the pressure on top of the diaphragm, allowing the gas pressure below to lift the diaphragm and open the valve.

When all the gas has bled off the top of the diaphragm, the valve is fully open, permitting gas flow to the main burner.

After the controller is satisfied, the procedure is reversed. The controller contacts open so the coil is de-energized. The plunger is released, moving to the DOWN position. This closes the bleed port and opens the supply port so gas flows again into the top port of the valve. As the gas pressure on top of the diaphragm increases, the diaphragm begins to close. When the pressures on both sides of the diaphragm are balanced, the valve will be closed. The weight and spring help to close the valve. If the gas supply fails and there is no pressure below the diaphragm, the weight and spring will close the valve.

In the event of a power failure during automatic operation, all V88 and V48 valves will close. Normal operation will be resumed upon power restoration.

Operation of the Valve Position Indicator (Fig. 11)

An optional valve position indicator is available in the 1-1/4 in. V48A2227 and 2 in. V48F1103 Valves. When the valve is open, a yellow disk shows in the window. When the valve is closed, only the black top of the disk is visible.

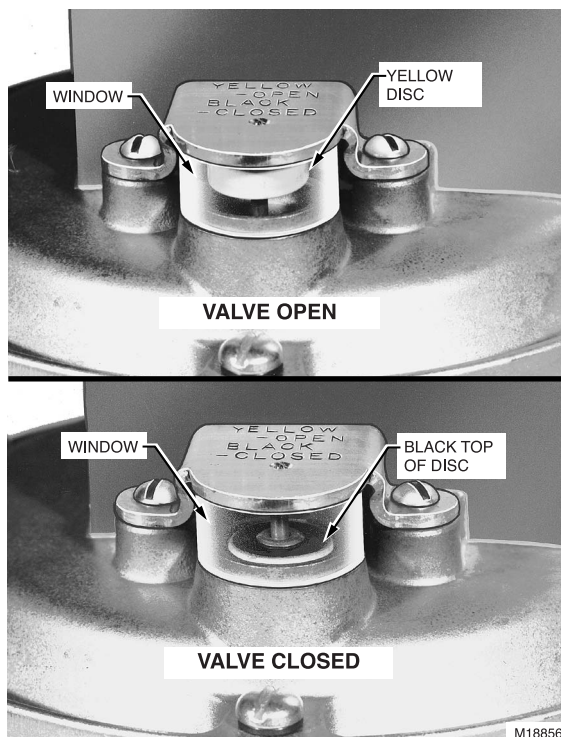

Fig. 11. Valve position indicator (optional).

CHECKOUT AND TROUBLESHOOTING

⚠ WARNING

Explosion Hazard.

Can cause severe injury, death or property damage.

Do not allow fuel to accumulate in the combustion chamber. If fuel is allowed to enter the chamber for longer than a few seconds without igniting, an explosive mixture could result.

⚠ CAUTION

Equipment Damage Hazard.

Can cause equipment damage and improper operation.

1. Do not put the system into service until you have satisfactorily completed all applicable tests described in the Checkout section of the instructions for the flame safeguard control, and any other tests required by the burner manufacturer.
2. Close all manual fuel shutoff valves as soon as trouble occurs.

Checkout

Start the system and observe its operation through at least one complete cycle to be sure the valve functions as described in the Operation section.

Troubleshooting

⚠ WARNING

Electrical Shock Hazard.

Can cause severe injury or death.

Use utmost care during troubleshooting. Line voltage is present at the actuator for a V48 Valve, and is present in all controller circuits for all V48 and V88 Valves.

IMPORTANT:

Do not assume that the valve must be replaced until all other sources of trouble have been eliminated.

If the valve will not open when the thermostat or controller is calling for heat:

1. Check that there is voltage at the valve actuator (black leadwires, Fig. 7). Be careful—there should be line voltage at the actuator of a V48.
2. If there is no voltage at the actuator, first make sure line voltage power is connected to the master switch, the master switch is closed, and overload protection (circuit breaker, fuse, or similar device) has not opened the power line.
3. For a V88 only: If a line voltage power is okay, check the transformer. Replace it if necessary.

4. If there is still no voltage at the actuator, make sure all the appropriate contacts in the thermostat (or controller), limit(s), and flame safeguard control are closed. If one or more is open, determine the cause(s) and correct the condition(s) before proceeding.
5. If there is proper voltage at the valve actuator but the valve still does not open, first check that the gas pressure at the valve is normal. Then make sure that the bleed line is unobstructed.
6. If the gas pressure and bleed line are okay but the valve still does not open, replace the coil assembly. (Refer to the Specifications section for the proper part number, and to the Service Information section for the proper procedure.)
7. If you replace the coil assembly and the valve still does not open, replace the valve.

If the valve will not close when one or more of the appropriate contacts in the thermostat (or controller), limit(s), or flame safeguard control is open:

1. Make sure that the gas flow is in the direction of the arrow on the valve body.
2. Make sure the valve actuator is wired in the correct circuit. Open the master switch to remove power from the valve actuator. If the valve closes now, the actuator may not be wired properly.
3. Look for a short in the electrical circuit.

SERVICE INFORMATION

WARNING

Electrical Shock Hazard.

Can cause severe injury or death.

1. Only qualified service technicians should attempt to service or repair flame safeguard controls and burner systems.
2. Open the master switch before replacing the coil assembly or the valve. Line voltage is present in the electrical circuits to the valve.

Scheduled Inspection and Maintenance

A schedule should be set up and followed for periodic inspection and maintenance for the burner and all other controls and the valve(s). Refer to the instructions for the flame safeguard control for more information.

Replacing the coil assembly (Figs. 12 through 15)

1. Open the master switch to disconnect all power to the valve actuator.
2. Loosen the cover screw in the front of the actuator housing (Fig. 12) and remove the housing cover.

3. Disconnect the external wires from the two internal black leadwires (Fig. 12).
4. Remove the two torx screws inside the actuator housing (Fig. 13) and lift off the housing.
5. Remove the holding nut from the top of the coil assembly (Fig. 13).
6. Lift the coil assembly straight up and off the plunger tube assembly (Fig. 14).
7. Snap out the wraparound metal cover and remove the metal base (Fig. 15). Save these parts for the replacement coil.
8. Carefully unhook the cardboard insulator (Fig. 15) and remove it. Save the insulator for the replacement coil.
9. Make sure the new coil assembly has the same part number as the old one; then discard the old coil assembly.
10. Wrap the cardboard insulator around the new coil assembly and carefully hook it together around the two black leadwires (Fig. 15).
11. Insert the two black leadwires through the opening in the metal base, and insert the new coil assembly into the metal base (Fig. 15).
12. Snap the wraparound metal cover into place around the new coil assembly (Fig. 15).
13. Slip the new coil assembly over the plunger tube assembly (Fig. 14).
14. Replace the holding nut on top of the coil assembly (Fig. 13) and tighten it securely.
15. Replace the actuator housing and tighten the two torx screws holding it in place (Fig. 13).
16. Reconnect the external wires to the two internal black leadwires (Fig. 12).
17. Replace the housing cover, and tighten the cover screw holding it to the actuator housing (Fig. 12).
18. Close the master switch.
19. Test the valve to make sure it opens and closes as described in the Operation section.
20. Verify proper operation after servicing.

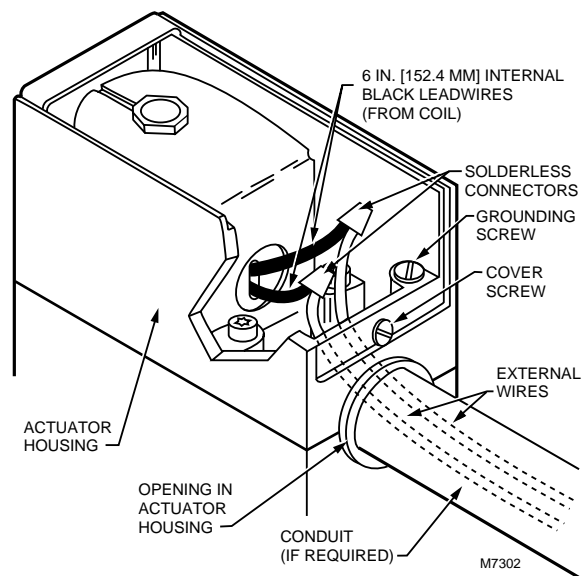

Fig. 12. Wiring connections and actuator housing.

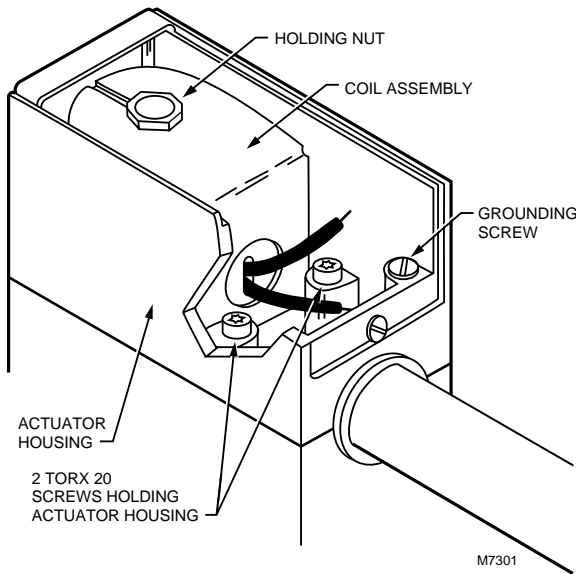

Fig. 13. Internal view of actuator housing.

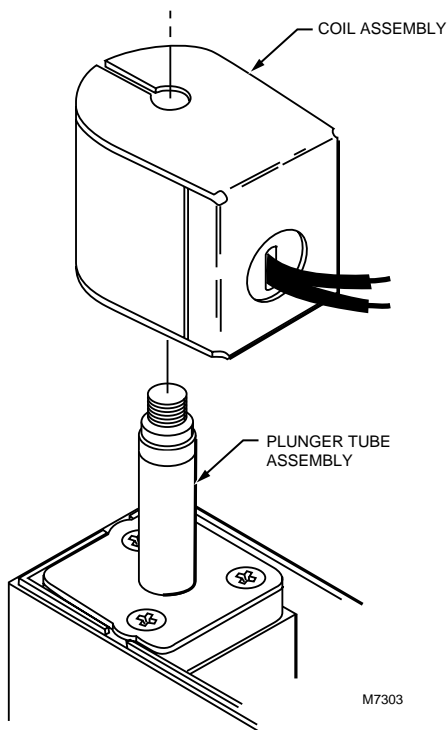

Fig. 14. Coil assembly fits on plunger tube assembly.

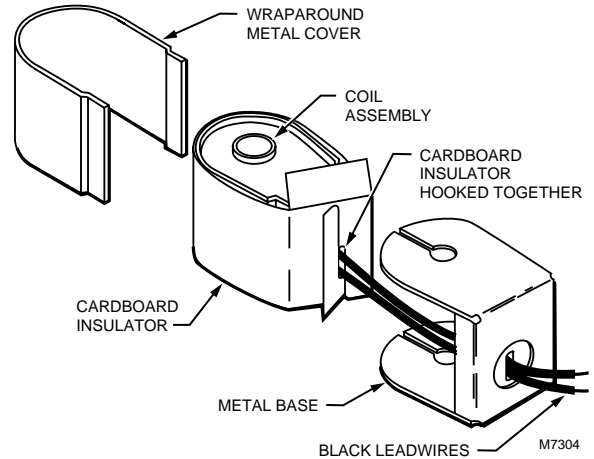

Fig. 15. Coil assembly, insulator, and cover.



CAUTION

Equipment Damage Hazard.
Operation without proper checkout can damage the equipment.

1. Do not put the system into service until you have satisfactorily completed the following Valve Leak Test, all applicable tests described in the Checkout section of the Instructions for the flame safeguard control, and any other tests required by the burner manufacturer.
2. All tests must be performed by a trained, experienced flame safeguard control technician.
3. Close all manual fuel shutoff valves as soon as trouble occurs.

After the installation is complete, cycle the valve several times with the manual fuel shutoff cock closed. Make sure the valve and actuator function properly. Also perform the Valve Leak Test that follows before putting the valve into service.

Valve Leak Test (Fig. 7)

This is a test for checking the closure tightness of a gas safety shutoff valve. It should be performed by qualified personnel during the initial startup of a burner system, or whenever the valve or valve bonnet is replaced (see Service Information section). It is recommended that this test also be included in the scheduled inspection and maintenance procedures. For a periodic inspection test, follow steps 1, 3, 4, 5, 8, 9, 10, 12, 13, 16, and 17.

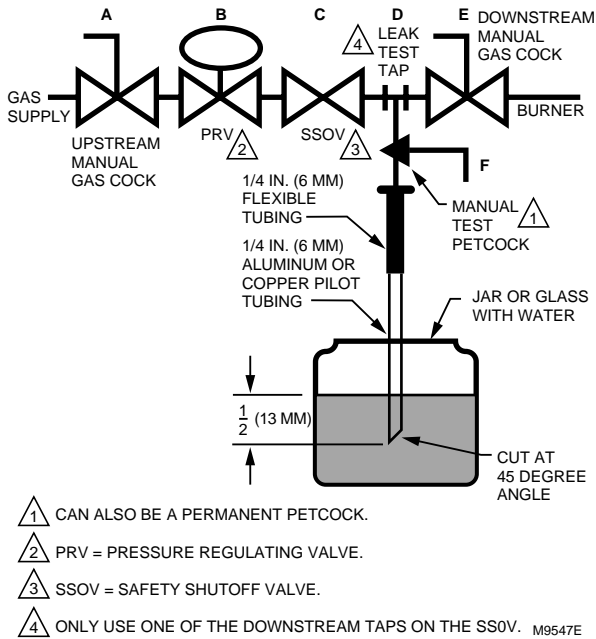

Fig. 16. Valve leak test.

1. De-energize the control system to assure that there is no power to the safety shutoff valve (C) shown in Fig. 7.
2. Close the upstream manual gas cock (A).
3. Make sure the manual test petcock (F) is closed in the leak test tap assembly (D).
4. Remove the leak test tap plug and connect the test apparatus to the Leak Tap (D).
5. Close the downstream manual gas cock (E).
6. Open the upstream manual gas cock (A).
7. Run the safety shutoff valve (C) to its fully open position (through the safety system); then immediately de-energize the system to close the valve.
8. Immerse a 1/4 in. tube vertically 1/2 in. (12.7 mm) into a jar of water.
9. Slowly open the test petcock (F).

10. When the rate of bubbles coming through the water stabilizes, count the number of bubbles appearing during a ten-second period. Each bubble appearing during a ten-second period represents a flow rate of approximately 0.001 cfh.

To meet U.S. requirements, leakage must not exceed the values listed in Table 5.

Table 5. Allowable Leakage for V48/V88 Valves.

V48/V88 Pipe Size (in.)	Air (cc/h)	Natural Gas (cc/h) ^a	Bubbles/10 sec.; Max @ 45 degrees ^b
3/4	266	332.5	8
1	302	377.5	9
1-1/4	442	552.5	13
1-1/2	442	552.5	13
2	650	812.5	20
2-1/2	650	812.5	20
3	650	812.5	20

^a Natural gas: multiply air by 1.25.

^b Bubble leakage: Divide natural gas by 573, then multiply by 14.

NOTE: For international leak test requirements, contact the office of the appropriate approval agency.

After the test:

11. Close the upstream manual gas cock (A).
12. Close the test petcock (F), remove the test apparatus, and replace the leak test tap plug (D).
13. Open the upstream manual gas cock (A) and energize the safety shutoff valve (C).
14. Test with soap bubbles to assure that there is no leak at the test tap (D).
15. De-energize the safety shutoff valve (C).
16. Open the downstream manual gas cock (E).
17. Restore the system to normal operation. If two safety shutoff valves are utilized, each V48/V88 valve is to be checked for tightness of closure.

Honeywell

Automation and Control Solutions

Honeywell
 1985 Douglas Drive North
 Golden Valley, MN 55422

Honeywell Limited-Honeywell Limitée
 35 Dynamic Drive
 Scarborough, Ontario
 M1V 4Z9