

C7031B,C,D,F,G,J,K Electronic Temperature Sensor

PRODUCT DATA

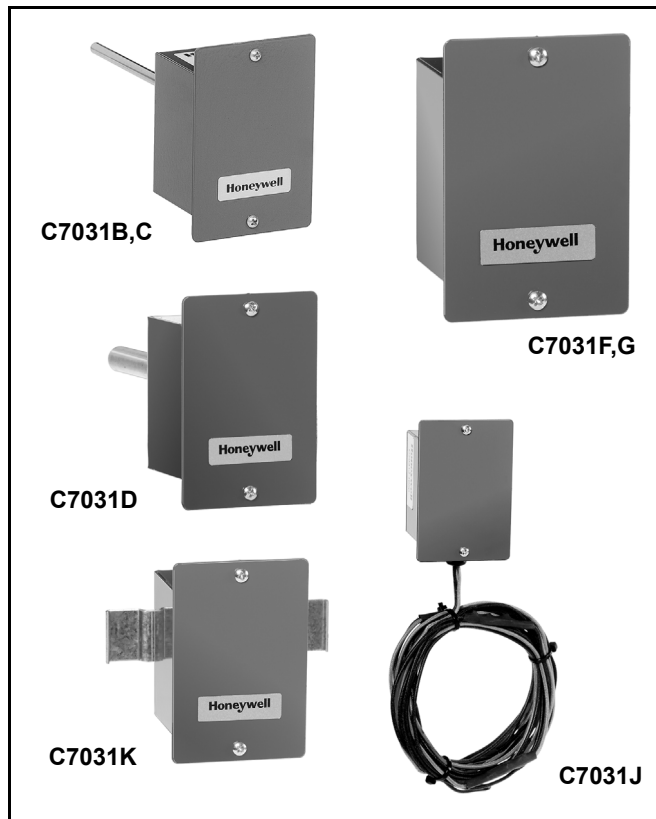

FEATURES

- C7031B,C,D,J sense duct air temperature.
- C7031B,D,K sense water temperature.
- C7031F,G sense outdoor air temperature.
- C7031K with strap-on mounting senses water temperature.
- C7031J senses average duct air temperature.
- Separate models available for use as primary or secondary sensors.
- Solid state components not affected by dust or dirt.
- Primary sensors C7031B,C,D,F,J,K can be used with a remote setpoint potentiometer.
- C7031D immersion sensor supplied complete with a separate well assembly.

APPLICATION

The C7031 Electronic Temperature Sensors are designed to be used with the W927, Excel 80, Excel 100, and Excel 500 Electronic Controllers in domestic or commercial heating and cooling systems.

Contents

| | |
|------------------------------|---|
| Application | 1 |
| Features | 1 |
| Specifications | 2 |
| Ordering Information | 2 |
| Installation | 5 |
| Operation and Checkout | 8 |



SPECIFICATIONS

Models: Use C7031 Temperature Sensors with controllers listed in Tables 1 and 2. (They are application specific.) See Tables 3 through 6 for the specifications.

Dimensions: See Fig. 1 through 5.

Sensor Response: See form 63-7074 for nominal resistance output vs. temperature in table form.

Accuracy for C7031 20K ohm Sensors:
±0.36°F (±0.2K) from 32° to 158°F (0° to 70°C).

Accessories:

32005960-001 Immersion Well: Used with C7031D in hot water applications.

S963B1011 Remote Setpoint Potentiometer: Used with C7031B,C,D,K in W927 Controller applications. Calibrated in degrees Fahrenheit.

Table 1. Electronic Primary Sensor Application Guide.

| Model | Control Application | Controller Used With | Sensor Type ^a |
|-------------------|---|-------------------------|--------------------------|
| C7031B | Duct discharge air or hot water (order immersion well separately) | | |
| 1009 | | W927G,H,J | NTC Thermistor |
| 1033 | | Excel 500, 100, 80, IRC | 20k ohm NTC Thermistor |
| C7031C | Duct discharge air | | |
| 1007 | | W927G,H,J | NTC Thermistor |
| 1031 | | Excel 500, 100, 80, IRC | 20k ohm NTC Thermistor |
| C7031D | Hot or chilled water (includes immersion well) | | |
| 1005 | | W927G,H,J | NTC Thermistor |
| 1047 ^b | | W927H,J | |
| 1062 | | Excel 500, 100, 80, IRC | 20k ohm NTC Thermistor |
| 1070 | | Excel 500 | PT1000 |
| C7031F | Outdoor air | | |
| 1018 | | Excel 500, 100, 80, IRC | 20k ohm NTC Thermistor |
| 1026 | | Excel 500 | PT1000 |
| C7031J | Duct discharge air (averaging sensor with 4 elements) | | |
| 1001 ^b | | W927G,H,J | NTC Thermistor |
| 1050 | | Excel 500, 100, 80, IRC | 20k ohm NTC Thermistor |
| 1068 | | Excel 500 | PT1000 |
| C7031K | Hot water (strap-on mounting) | | |
| 1009 ^b | | W927G,H,J | NTC Thermistor |
| 1017 | | Excel 500, 100, 80, IRC | 20k ohm NTC Thermistor |
| 1025 | | Excel 500 | PT1000 |

^a See Tables 4 and 5 for thermistor specifications; see Table 6 for PT1000 platinum sensor specifications.

^b Obsolete at time of printing.

ORDERING INFORMATION

When purchasing replacement and modernization products from your TRADELINE® wholesaler or distributor, refer to the TRADELINE® Catalog or price sheets for complete ordering number.

If you have additional questions, need further information, or would like to comment on our products or services, please write or phone:

1. Your local Honeywell Automation and Control Products Sales Office (check white pages of your phone directory).
2. Honeywell Customer Care
1885 Douglas Drive North
Minneapolis, Minnesota 55422-4386

In Canada—Honeywell Limited/Honeywell Limitée, 35 Dynamic Drive, Scarborough, Ontario M1V 4Z9.

International Sales and Service Offices in all principal cities of the world. Manufacturing in Australia, Canada, Finland, France, Germany, Japan, Mexico, Netherlands, Spain, Taiwan, United Kingdom, U.S.A.

Table 2. Electronic Secondary Sensor Application Guide.

| Model | | Control Application | Controller Used With | Sensor Type ^a |
|--------|-------------------|---|----------------------|--------------------------|
| C7031B | 1009 | Secondary anticipation from duct discharge temperature | W927D-F | NTC Thermistor |
| C7031C | 1007 ^b | Secondary anticipation from duct discharge temperature | W927D-F | |
| C7031F | 1000 | Outdoor reset of discharge air temperature | W927G,H,J | |
| C7031G | 1016 | Outdoor reset of room temperature | W7100 | |
| C7031J | 1001 ^b | Secondary anticipation from duct discharge temperature (averaging sensor with 4 elements) | W927D-F | |

^a See Tables 4 through 6 for thermistor specifications.

^b Obsolete at time of printing.

Table 3. C7031 Sensor Specifications.

| Model | Element Insertion Length in in. (mm) | Weight in oz (kg) | Dimensions (Fig.) |
|----------|--------------------------------------|-------------------|-------------------|
| C7031B | 5 (127) | 9 (0.26) | 1 |
| C7031C | 18 (457) | | |
| C7031D | 3-3/8 (86) | 14 (0.40) | 2 |
| C7031F,G | — | 9 (0.26) | 3 |
| C7031J | 150 (3810) | 12 (0.34) | 4 |
| C7031K | ^a | 13 (0.37) | 5 |

^a Strap-on model not equipped with well; temperature sensed at surface of pipe.

Table 4. Specifications of the C7031 20k ohm Sensors.

| Model | Element Operating Range | Element Maximum Ambient Temperature | Sensor Resistance ^a (ohms) at 77°F (25°C) |
|--------|-------------------------------|-------------------------------------|--|
| C7031B | -40° to 250°F (-40° to 121°C) | 302°F (150°C) | 20,000 |
| C7031C | | | |
| C7031D | | | |
| C7031F | | | |
| C7031J | | | |
| C7031K | | | |

^a Nonlinear resistance decreases as temperature increases.

Table 5. Specifications of the C7031 Sensors used with the W927 Controller.

| Model | Element Operating Range | Element Maximum Ambient Temperature | Sensor Resistance ^a in ohms at 74°F (23°C) | Control Sensitivity in ohms per degree F (per degree C) for element operating range |
|-------------------------|------------------------------|-------------------------------------|---|---|
| C7031B,C | 40° to 140°F (4° to 60°C) | 240°F (115°C) | 1772 | 4.2 (7.6) |
| C7031D1005 | 40° to 240°F (4° to 115°C) | | | |
| C7031D1047 ^b | 40° to 240°F (4° to 115°C) | | | |
| C7031F | -40° to 110°F (-40° to 43°C) | 110°F (43°C) | 947 | 13.6 (24.5) |
| C7031G1016 | -40° to 110°F (-40° to 43°C) | 110°F (43°C) | 1750 (1715 at 90°F) | 2.2 (3.4) |
| C7031J1001 ^b | 40° to 180°F (4° to 82°C) | 225°F (107°C) | 1772 | 4.2 (7.6) |
| C7031K1009 ^b | 40° to 240°F (4° to 115°C) | 240°F (115°C) | | |

^a Resistance decreases as temperature increases.

^b Obsolete at time of printing.

Table 6. Specifications of the C7031 PT1000 Platinum Class A Sensors.

| Model | Element Operating Range | Element Maximum Ambient Temperature | Sensor Resistance ^a (ohms) at 74°F (23°C) | Control Sensitivity in ohms per degree F (per degree C) for element operating range |
|--------|------------------------------|-------------------------------------|--|---|
| C7031D | 40° to 240°F (4° to 115°C) | 240°F (115°C) | 1090 | 2.1 (3.9) |
| C7031F | -40° to 110°F (-40° to 43°C) | 110°F (43°C) | | |
| C7031J | 40° to 180°F (4° to 82°C) | 225°F (107°C) | | |
| C7031K | 40° to 240°F (4° to 115°C) | 240°F (115°C) | | |

^a Resistance increases as temperature increases.

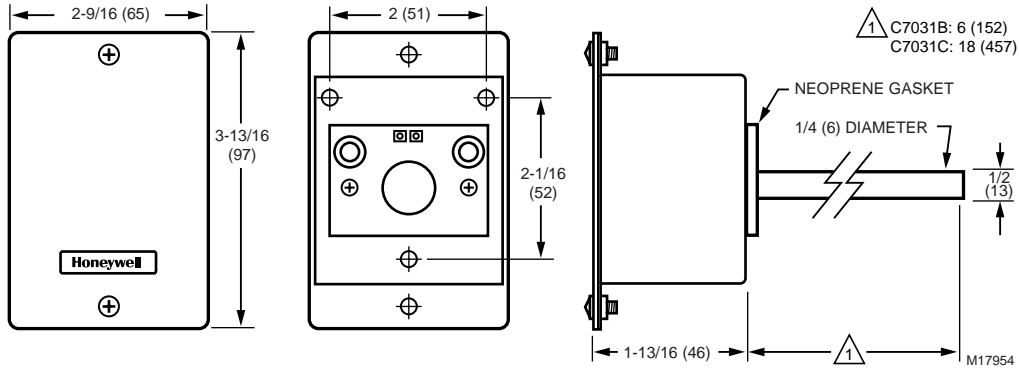

Fig. 1. C7031B,C dimensions in in. (mm).

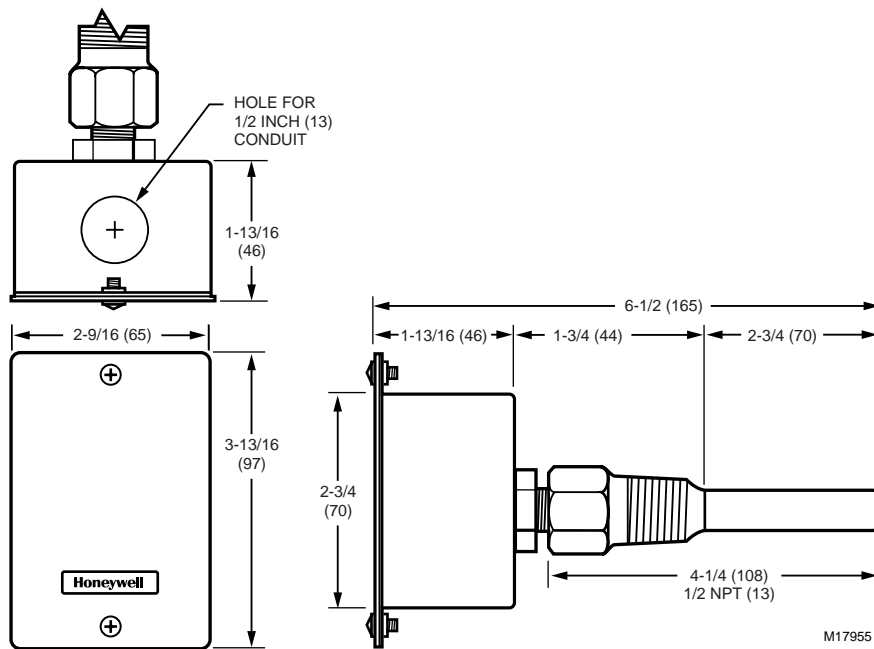

Fig. 2. C7031D dimensions in in. (mm).

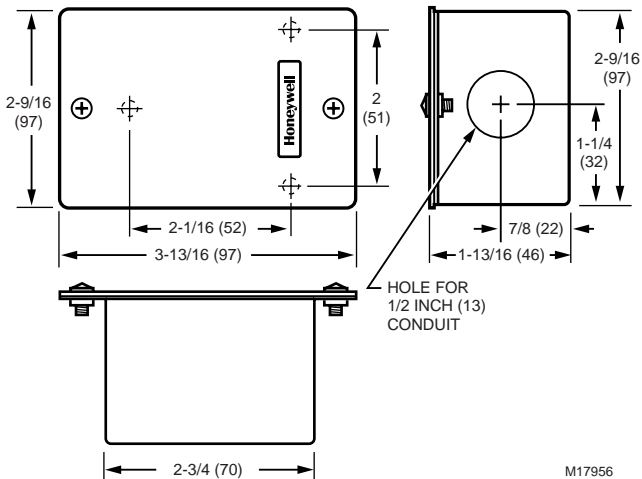

Fig. 3. C7031F,G dimensions in in. (mm).

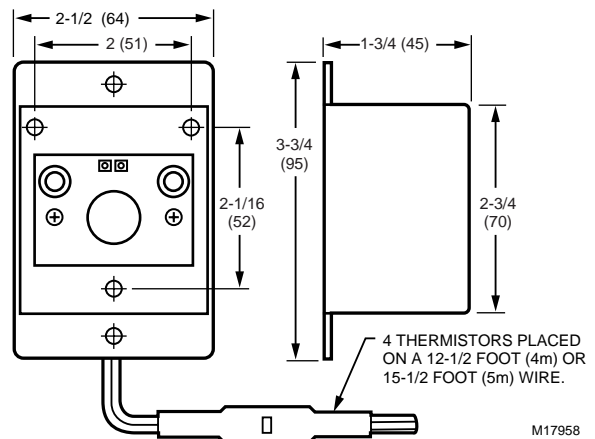

Fig. 4. C7031J dimensions in in. (mm).

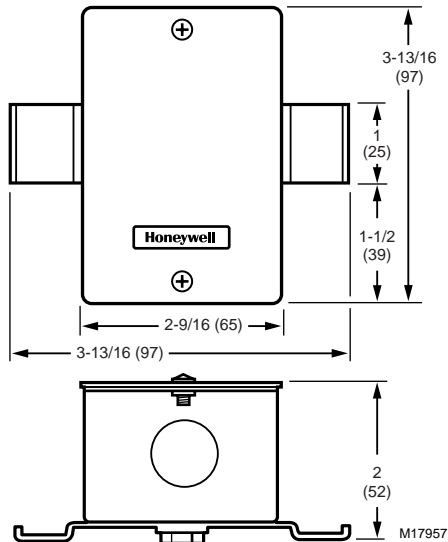

Fig. 5. C7031K dimensions in in. (mm).

INSTALLATION

When Installing this Product...

1. Read these instructions carefully. Failure to follow them could damage the product or cause a hazardous condition.
2. Check the ratings given in the instructions and on the product to make sure the product is suitable for your application.
3. Installer must be a trained, experienced service technician.
4. After installation is complete, check out product operation as provided in these instructions.



CAUTION

Electrical Shock or Equipment Damage Hazard.
Can shock individuals or short equipment circuitry.

Disconnect power supply before installation.

Mounting

The method of mounting depends on the particular application of the C7031 Temperature Sensor. The following procedures include outdoor, duct, immersion well and strap-on applications. Also refer to the instructions for the electronic control.

Outdoor Mounting

The C7031F,G are used to sense outdoor air temperature. Mount these controls where they will sense average outdoor air temperature. Normally, the north side of the building provides a suitable location. Avoid a location where sunlight, clothes dryer or fan exhaust, or other heat sources could affect sensor accuracy.

1. Use the dimensions in Fig. 1 or use the device itself to mark the location for the three mounting holes.
2. Drill pilot holes and use the three screws provided to mount the C7031F,G.

Duct Mounting

The C7031B,C can be mounted in a duct to sense air temperature.

IMPORTANT

Select a spot for the C7031 where it will be exposed to average duct air temperature. Avoid locations where stratification can cause sensing errors.

1. Cut a hole in the duct just large enough to accept the sensing element.
2. Use the sensor case to mark the locations of the pilot holes for the mounting screws.
3. Drill the pilot holes and fasten the sensor to the duct with the screws provided.

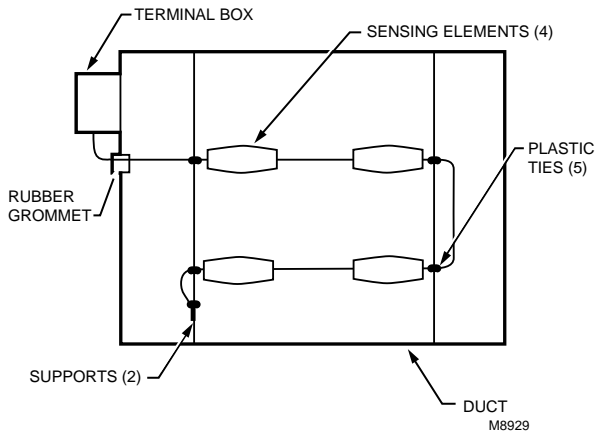

Fig. 6. Duct cross section showing method of installing C7031J Averaging Electronic Sensor.

1. Install two supports inside the duct to hold the averaging element.
2. Cut a 7/8 in. (22 mm) hole in the side of the duct to insert the averaging element.
3. Fasten the terminal box to the outside of the duct and thread the element through the hole and into the duct.
4. Use the plastic wire ties to fasten the element to the supports. Seal the hole around the element with the rubber grommet.
5. Secure the end of the element to the duct on the support to prevent continuous flexing or abrasion.

IMPORTANT

To assure that the C7031J senses the average duct temperature, position the temperature sensitivity elements approximately as shown in Fig. 6. Do not allow the sensing elements to touch or be close to the sides of the duct.

NOTE: When the C7031J is used as a deck sensor in a multizone system, be sure to space the elements equally in the duct midstream as shown in Fig. 7.

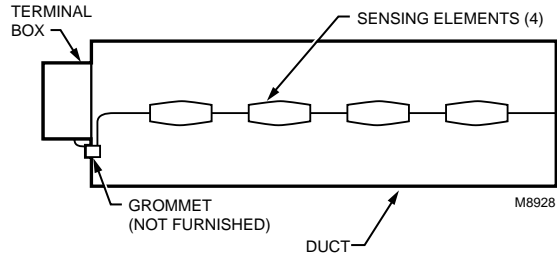

Fig. 7. Duct cross section showing method of installing C7031J Sensor in a multizone system.

Install one C7031J Sensor just upstream from the cold deck zone dampers and the other C7031J Sensor upstream from the hot deck zone dampers. Position the thermistors to sense the average deck temperature.

Immersion Well Mounting

The C7031D Sensor is supplied with an immersion well. For the C7031B Sensor, a well can be ordered as an accessory.

When used on a boiler, follow the manufacturer instructions for location. If a tapped hole is not provided for the immersion well, provide one as follows:

1. Drain boiler and drill a 23/32 in. (18 mm) hole at the selected location.
2. Cut threads in the hole with a 1/2 in. (13 mm) by 14 NPT tap.

In other installations, mount the immersion well in an elbow with a heel outlet as shown in Fig. 8.

1. Drain the system, if you have not already done it, and open the tapped hole.
2. Put pipe joint compound on the threads of the immersion well and screw it into the tapped hole or elbow, tightening it securely.
3. Refill the system and check for leaks.

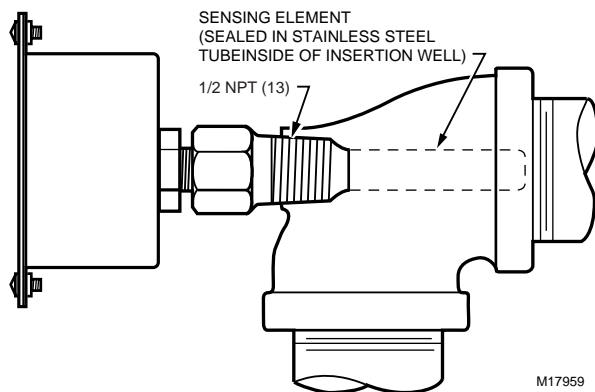

Fig. 8. Method of mounting C7031D Sensor.

Strap-On Mounting

Strap-on mounting is well-suited for retrofit applications where installation costs can be reduced by not draining the system. The C7031K Sensor mounts on metal pipes from one inch to four inches in diameter using the straps supplied. Clean the surface of the pipe where the sensor makes contact before mounting (remove insulation from the pipe at the point of installation if necessary). Thermal compound is recommended with the strap-on C7031K Sensor. The time constant with the compound is 30 seconds; without the compound, the time constant is two minutes. Locate the sensor on the discharge pipe within 3 feet (0.9m) of the boiler. See Fig. 9.

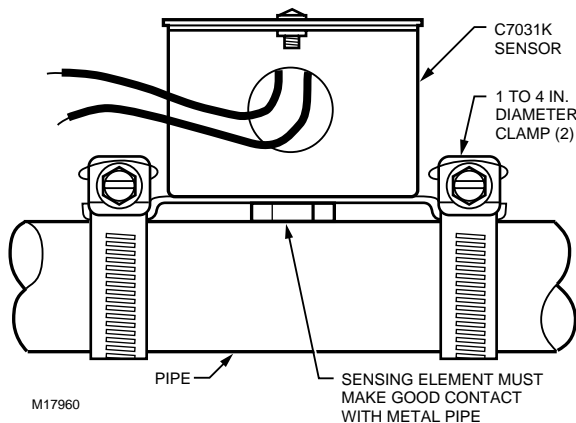

Fig. 9. Strap-on mounting of C7031K Sensor.

Wiring



CAUTION

Electrical Shock or Equipment Damage Hazard.
Can shock individuals or short equipment circuitry.

Disconnect power supply before installation.



CAUTION

Erratic System Operation Hazard.
Failure to follow proper wiring practices can introduce disruptive electrical interference (noise).

Keep wiring at least one foot away from large inductive loads such as motors line starters, lighting ballasts, and large power distribution panels.

Shielded cable is required in installations where these guidelines cannot be met.

Ground shield only to grounded controller case.

IMPORTANT

1. All wiring must agree with applicable codes, ordinances and regulations.
2. Do not mount sensor in incorrect environment.
3. Wire according to the applicable controller instructions.

OPERATION AND CHECKOUT

Operation

The C7031 Temperature Sensors are designed for use with W927, Excel 500, Excel 100, and Excel 80 Electronic Controllers. As the temperature at the C7031 Sensor changes, the resistance of the sensor changes, causing the controller to operate and offset the temperature change.

Checkout

Refer to the applicable controller instructions when checking out the complete heating and cooling systems.

To check out the sensors, move the thermostat or remote setpoint potentiometer below the temperature of the cooling or heating medium. Watch the motor, valve or damper for the correct movement.

Honeywell

Automation and Control Solutions

| | |
|------------------------------|-------------------------------------|
| Honeywell International Inc. | Honeywell Limited-Honeywell Limitée |
| 1985 Douglas Drive North | 35 Dynamic Drive |
| Golden Valley, MN 55422 | Scarborough, Ontario |
| | M1V 4Z9 |

