

C7400A Solid State Enthalpy Sensor

PRODUCT DATA



FEATURES

- Senses and combines temperature and humidity of outdoor air.
- Long lasting solid state thermistor sensing element is accurate and stable over time.
- As enthalpy of outdoor air increases, the outdoor air damper closes to a preset minimum position.
- As enthalpy of outdoor air becomes low, the outdoor air damper opens to reduce the cooling load in the building.
- Maximum economizer savings is achieved when two C7400A Solid State Enthalpy Sensors are connected to one W7459 or W6210/W7210, W6215/W7215, W7212/W7213/W7214, W7460 Solid State Economizer Logic Module for differential enthalpy changeover control.
- Compact size and lightweight construction allows easy mounting in HVAC rooftop unit.
- Sensor is enclosed in a rugged, corrosion-resistant glass-fiber reinforced plastic duct-mount case.
- Provides a 4 to 20 mA output signal to W7459 or W6210/W7210, W6215/W7215, W7212/W7213/W7214, W7460 Solid State Economizer Logic Module; setpoint is located on the logic module.

APPLICATION

The C7400A Solid State Enthalpy Sensor is used with the W7459 or W6210/W7210, W6215/W7215, W7212/W7213/W7214, W7460 Solid State Economizer Logic Modules. It permits the use of outdoor air as the first stage of cooling in heating, ventilating and air conditioning (HVAC) systems.

SPECIFICATIONS

Model: C7400A Solid State Enthalpy Sensor.

Dimensions: See Fig. 1.

Output Signal: 4 to 20 mA current signal increases from 4 mA to 20 mA as enthalpy decreases.

Ambient Temperature Ranges:

Operating: 32°F to +125°F (0°C to +52°C).
Shipping: -40°F to +150°F (-40°C to +66°C).

Maximum Power Consumption: 0.50 VA at 24 Vdc.

Supply Voltage: 12 to 40 Vdc.

Electrical Connections:

Two 1/4 in. (6 mm) quick connect terminals.

Approvals:

Underwriters Laboratories Inc. Flammability Rating: UL94-5V.

INSTALLATION

When Installing this Product...

1. Read these instructions carefully. Failure to follow them could damage the product or cause a hazardous condition.
2. Check the ratings given in the instructions and on the product to make sure the product is suitable for your application.
3. Installer must be a trained, experienced service technician.
4. After installation is complete, check out product operation as provided in these instructions.

CAUTION

Electrical Shock or Equipment Damage Hazard.
Can shock individuals or short equipment circuitry.

Disconnect power supply before installation.

Follow specific installation instructions furnished by the HVAC equipment manufacturer. If not available, use this procedure.

ORDERING INFORMATION

When purchasing replacement and modernization products from your TRADELINE® wholesaler or distributor, refer to the TRADELINE® Catalog or price sheets for complete ordering number.

If you have additional questions, need further information, or would like to comment on our products or services, please write or phone:

1. Your local Honeywell Automation and Control Products Sales Office (check white pages of your phone directory).
2. Honeywell Customer Care
1885 Douglas Drive North
Minneapolis, Minnesota 55422-4386

In Canada—Honeywell Limited/Honeywell Limitée, 35 Dynamic Drive, Scarborough, Ontario M1V 4Z9.

International Sales and Service Offices in all principal cities of the world. Manufacturing in Australia, Canada, Finland, France, Germany, Japan, Mexico, Netherlands, Spain, Taiwan, United Kingdom, U.S.A.

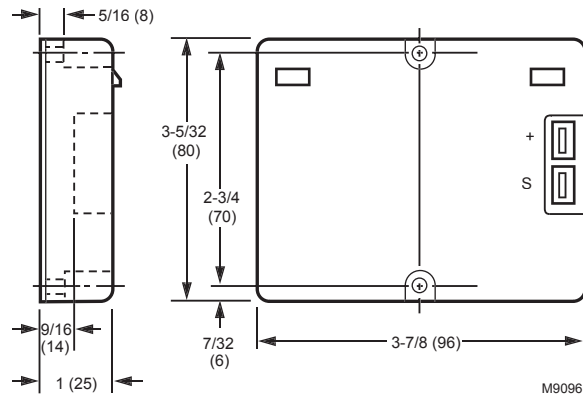

Fig. 1. Approximate dimensions of C7400A Solid State Enthalpy Sensor in in. (mm).

Location

IMPORTANT

When selecting the location, make sure the C7400A Solid State Enthalpy Sensor is not exposed to rain, snow or direct sunlight.

NOTES:

- The C7400A Sensor can be mounted in any position. However, the sensor must be installed where it is exposed to freely circulating air, but protected from rain, snow and direct sunlight.
- Differential enthalpy control requires two C7400A Sensors. Mount one sensor in the outdoor intake duct, the other in the return air duct.
- The C7400A Sensor is designed to operate in 500 ft/min. minimum airflow.

Wiring

IMPORTANT

All wiring must agree with applicable codes, ordinances and regulations.

Follow the wiring information furnished by the HVAC equipment manufacturer or see Fig. 2 for typical wiring hookups.

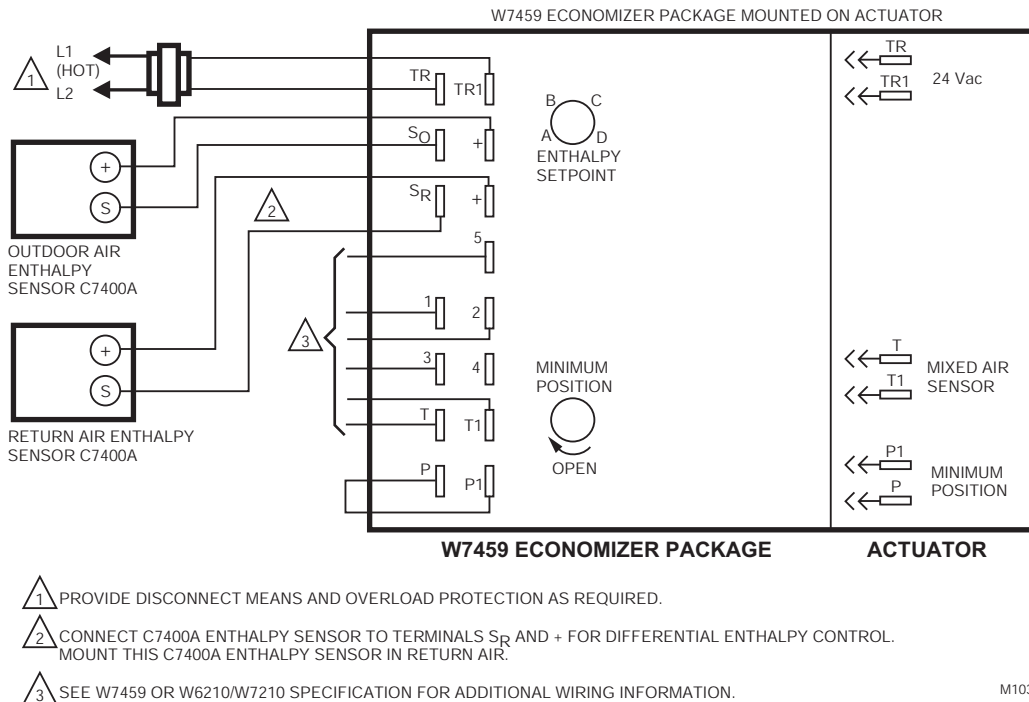

Fig. 2. Wiring connections for C7400A Solid State Enthalpy Sensors.

OPERATION

Controller Dial Setting

Control setpoint scale is located on the W7459 and W6210/W7210 Solid State Economizer Logic Modules. Control points A,B,C,D are field selectable and are used for single enthalpy sensing. Turn to D (fully clockwise) when differential enthalpy control is desired. When differential enthalpy control is desired, two enthalpy sensors must be connected to the economizer logic module.

Operation

The C7400A Solid State Enthalpy Sensor is used with a solid state economizer logic module and damper actuator to proportion an outdoor air damper in a ventilation system.

Each enthalpy control setpoint (A, B, C, and D) combines temperature and humidity conditions, resulting in the control curve shown in Fig. 4. When the enthalpy of the outdoor air is below (left of) the appropriate curve, the outdoor air damper can proportion open on a call for cooling. If the outdoor enthalpy rises above (right of) the control curve, the outdoor air damper closes to the minimum position.

NOTE: Curves illustrate reset in temperature control point due to changes in relative humidity.

For differential enthalpy, turn the control setpoint to D (fully clockwise)

- If outdoor air enthalpy is lower than return air enthalpy, the outdoor air damper proportions open on a call for cooling.
- If outdoor air enthalpy is higher than return air enthalpy, the outdoor air damper closes to minimum position. Differential

enthalpy control provides energy savings and increased comfort by using the air with the lowest enthalpy.

- If outdoor air enthalpy and return air enthalpy are equal, the outdoor air damper proportions open on a call for cooling.

NOTE: The relationship between the C7400A Sensor output current and relative humidity is shown in Fig. 3.

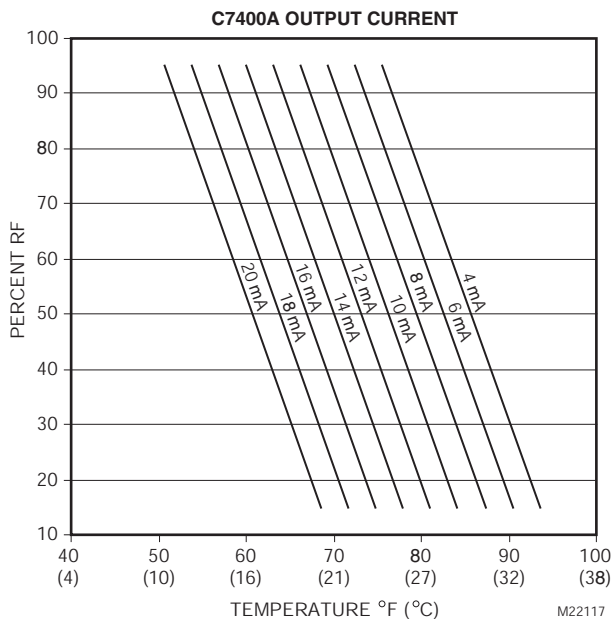

Fig. 3. C7400A Sensor output current vs. rh.

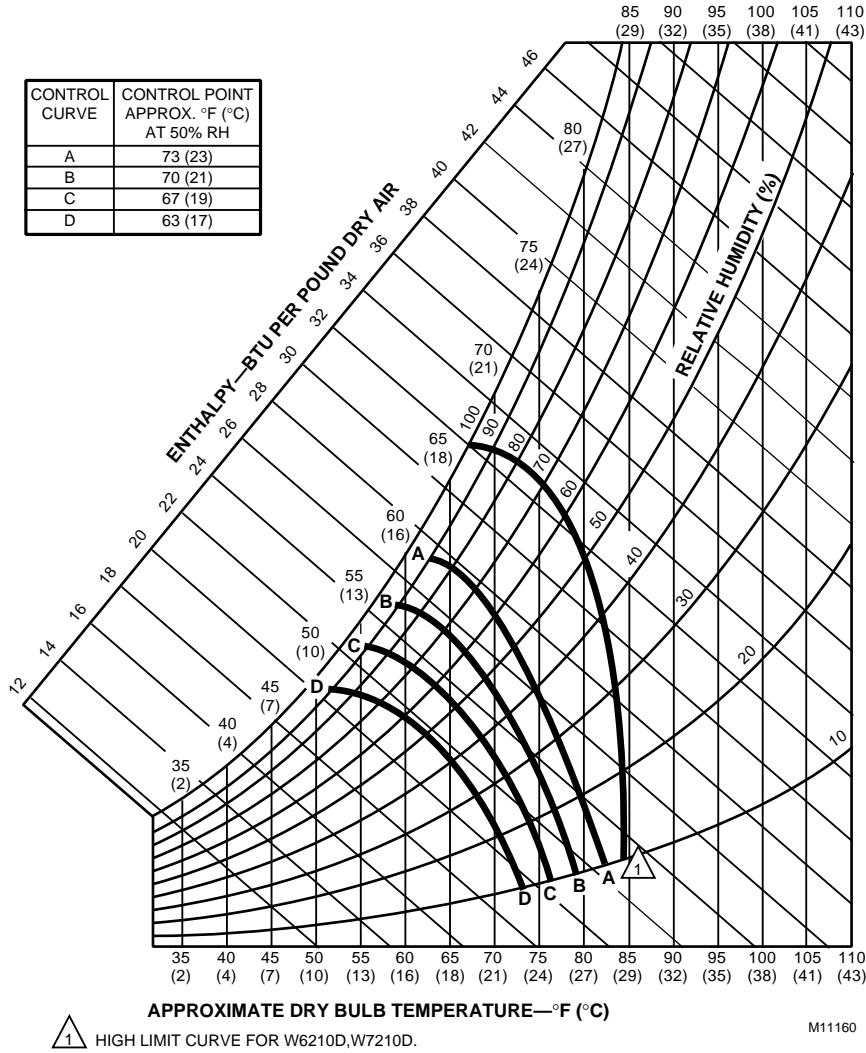

Fig. 4. Partial psychrometric chart with single C7400 Solid State Enthalpy Sensor and W7459, W6210/W7210, W6215/W7215, W7212/W7213/W7214, W7460 Solid State Economizer Logic Module performance Curves.

Honeywell

Automation and Control Solutions

Honeywell International Inc. 1985 Douglas Drive North Golden Valley, MN 55422
 Honeywell Limited-Honeywell Limitée 35 Dynamic Drive Scarborough, Ontario M1V 4Z9

Honeywell International

Control Products Honeywell Building 17 Changi Business Park Central 1 Singapore 486073

Honeywell Europe S.A.

3 Avenue du Bourget 1140 Brussels Belgium

Honeywell Latin American Region

480 Sawgrass Corporate Parkway Suite 200 Sunrise FL 33325

