

Boiler Control System BCS 7700 Q7710 Firing Rate Interface

The Q7710 Firing Rate Interface is designed for use with the BCS 7700. The BCS 7700 is a microprocessor-based integrated control system for gas, oil, or combination fuel single burner applications. The Q7710 Firing Rate Interface enables the BCS 7700 to interface with a variable resistance [135 ohm], variable voltage [1-5 Vdc], or variable current [4-20 mA] controller. Certain BCS 7700 applications will require interfacing with external controllers such as lead-lag, reset systems, or 4-20 mA PID. Such controllers have an incompatible control signal for the BCS 7700.

The Q7710 Firing Rate Interface provides variable voltage outputs to be processed by the BCS 7700 to define the firing rate motor position. One Q7710 Firing Rate Interface can be used with the family of BCS 7700 Program Modules (type PM7700).



- Multiple control value input; 135 ohm, 4-20 mA, 1-5 Vdc.
- Status indicating LEDs for POWER and ENABLE.

- Enhances BCS 7700 application flexibility.
- Small compact design.

CONTENTS

Specifications	2
Ordering Information.....	2
Installation	3
Operation	6
Checkout.....	7

Specifications

ELECTRICAL RATINGS:

Voltage and Frequency:
 120 Vac +10/-15% 50/60 Hz Enable Input.
 8 Vdc, 0.02A provided by the BCS 7700.

ENVIRONMENTAL RATINGS:

Ambient Temperature:
 Operating: 32° F to 130° F.
 Storage: -30° F to 150° F.
 Humidity: Operating 85% RH continuous, noncondensing.
 Vibration: Continuous 0.5G environment.
 Dimensions: See Fig. 1.
 Weight: 7.5 oz unpacked.

ACCESSORIES:

4074ENQ Connector Bag Assembly

APPROVAL BODIES:

Underwriters Laboratories Inc., component recognized:
 File No. MP 268, Guide No. MCCZ2.
 Canadian Standards Association certified: LR80141.
 Factory Mutual approved.

Fig. 1—Dimensional drawing in in. [mm].

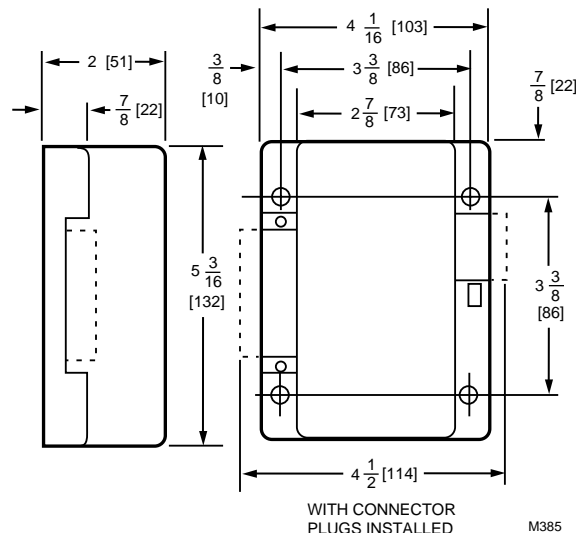

TERMINAL RATINGS:

Terminal No.	Description	Rating
B-R-W	Firing Rate Controller, potentiometer	133 - 155 ohm
V-COM	Firing Rate Controller, variable voltage	1 - 5 Vdc ^a
MA-COM	Firing Rate Controller, variable current	4 - 20 mA dc ^b
36-38	Power Supply from BCS 7700	8.0 +/- .025 Vdc
37-38	Firing Rate Signal, BCS 7700 Steam Sensor Input	5.75 - 1.25 Vdc
32 -38	Firing Rate Signal, BCS 7700 Water Temp Sensor Input	1.65 - 2.87 Vdc
EN - L2	Line Voltage Enable Input	120 +10/-15% Vac 50/60 Hz
E	Earth Ground	

^a Current source must be capable of providing a minimum 13.2 Vdc when output current is 20 mA.

^b Voltage source must be capable of providing a minimum 3 mA when output voltage is 5 Vdc.

Ordering Information

When purchasing replacement and modernization products from your TRADELINE[®] wholesaler or distributor, refer to the Tradeline Catalog or price sheets for complete ordering number, or specify—

1. Order number.
2. Accessories, if desired.
3. Order additional system components and system accessories separately.

If you have additional questions, need further information, or would like to comment on our products or services, please write or phone:

1. Your local Home and Building Control Sales Office (please check the white pages of your phone directory).
2. Home and Building Control Customer Logistics
 Honeywell, Inc., 1885 Douglas Drive North
 Minneapolis, Minnesota 55422-4386 (612) 951-1000

In Canada—Honeywell Limited/Honeywell Limitée, 740 Ellesmere Road, Scarborough, Ontario M1P2V9. International Sales and Service Offices in all principal cities of the world. Manufacturing in Australia, Canada, Finland, France, Germany, Japan, Mexico, Netherlands, Spain, Taiwan, United Kingdom, U.S.A.

Installation

WHEN INSTALLING THIS PRODUCT...

1. Read these instructions carefully. Failure to follow them could damage the product or cause a hazardous condition.
2. Check ratings given in the instructions and on the product to make sure the product is suitable for your application.
3. Installer must be a trained, experienced flame safeguard technician.
4. After installation, check out the product as provided in these instructions.

HUMIDITY

Install the Firing Rate Interface, see Fig. 2, where relative humidity never reaches the saturation point. The Firing Rate Interface is designed to operate in an 85% RH continuous, noncondensing moisture environment. Condensing moisture may cause improper operation.

VIBRATION

Install the Firing Rate Interface where it will not be subjected to excessive vibration, 0.5G continuous maximum.

WEATHER

The Firing Rate Interface is not designed to be weather tight. If installed outdoors, it must be protected.

MOUNTING THE FIRING RATE INTERFACE

NOTE: For installation dimensions, see Fig. 1.

1. Mount the Firing Rate Interface vertically or horizontally in the same electrical enclosure as the BCS 7700 and on the same subpanel.
2. Select the location in the electrical enclosure. Allow an additional 1.5 inches minimum on each side for electrical connector installation and removal.
3. Using the Firing Rate Interface as a template, mark the four screw locations.
4. Mount the Firing Rate Interface and secure with four no. 8 screws, 1 in. [25mm] long.

WIRING



CAUTION

1. Disconnect power supply before beginning installation to prevent electrical shock and equipment damage. More than one power disconnect may be involved.
2. Wiring must comply with all applicable codes, ordinances and regulations.
3. Wiring must comply with NEC Class 1 (Line Voltage), except for firing rate circuits.
4. Refer to Figs. 3 and 4 for proper system wiring.

Fig. 2—Firing Rate Interface components.

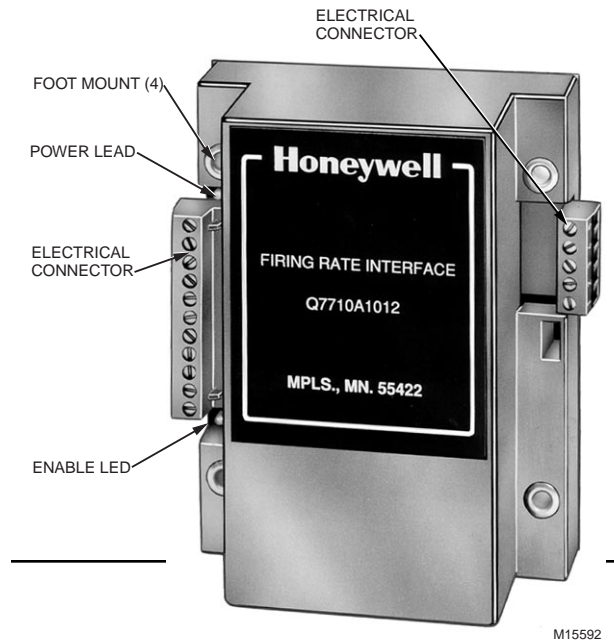

M15592

1. Refer to Figs. 3 and 4 for proper wiring configurations.
2. Before beginning wiring to the electrical connectors, assure power is removed from the control panel by opening the main disconnect. More than one power disconnect may be involved.
3. Wiring must comply with all applicable electrical codes, ordinances, and regulations.
4. Use recommended wire size and type.
Line voltage terminals and terminal identification numbers are in brackets []:
 - Line voltage enable signal [EN-L2].
 - Earth ground [E].
 No. 14 copper conductors TW60C or THW75C or THHN90C.
 Low voltage sensor terminals and terminal identification numbers are noted within brackets []:
 - Power Supply from BCS 7700 [36-38].
 - Firing Rate Signal, if Steam Sensor Input [37-38] is used (hot water boiler).
 Belden 9365 [rating 300V service 105C] or equivalent.
 Belden 8770 [rating 300V service 60C] or equivalent.
 - Firing Rate Signal, if Water Sensor Input [32-38] is used (steam boiler).
 Belden 9341 [rating 600V service 90C] or equivalent.
 Belden 9318 [rating 300V service 105C] or equivalent.
 - Firing Rate Controller, 135Ω [B-R-W]
 Belden 9365, 8770 or equivalent.
 - Firing Rate Controller, 1-5 Vdc [V-COM]
 Belden 9341, 9318 or equivalent.
 - Firing Rate Controller, 4-20 mA [MA-COM]
 Belden 9341, 9318 or equivalent.

5. Recommended grounding practice is to use shielded cable for the temperature and pressure sensor inputs. The shield must not be connected at the Firing Rate Interface end; it should be taped to avoid unintended contact with the Firing Rate Interface housing or mounting. At the BCS 7700 end, the shield must be grounded to the control panel with lead length as short as possible. The Firing Rate Interface Earth ground terminal [E] must be connected to the same subpanel as the BCS 7700 with grounding conductor as short as practical.

6. Recommended wire routing:

- a. Do not route signal leadwires in conduit carrying line voltage circuits.
 - b. Avoid routing signal leadwires close to the ignition transformer leadwires.
 - c. Route low voltage signal leadwires outside of conduit if properly supported and protected from damage.
7. Check all wiring with Fig. 3 and/or 4 before installing electrical connectors.
 8. Install all electrical connectors.
 9. Restore power to the panel.

Fig. 3—Steam boiler wiring diagram.

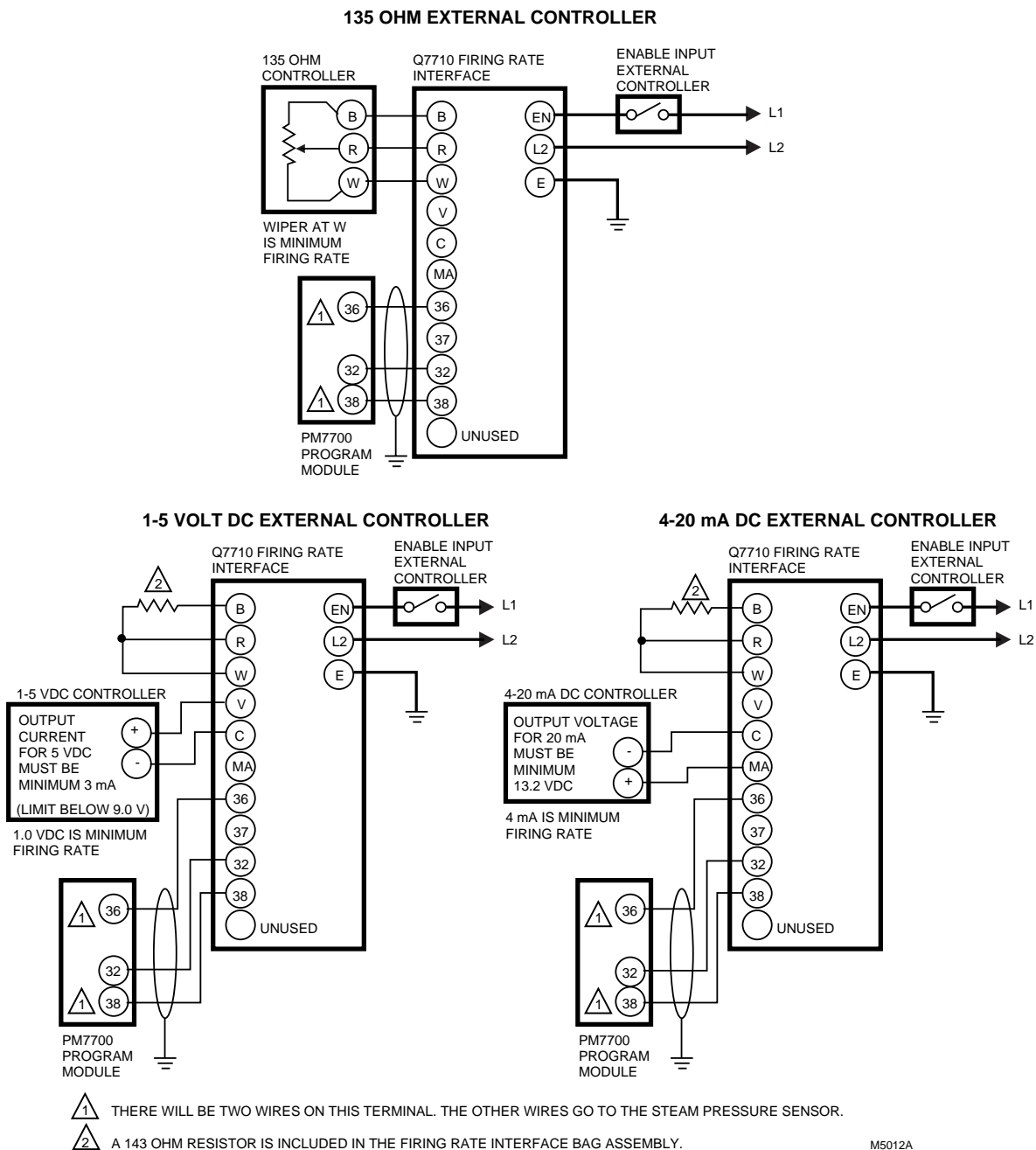
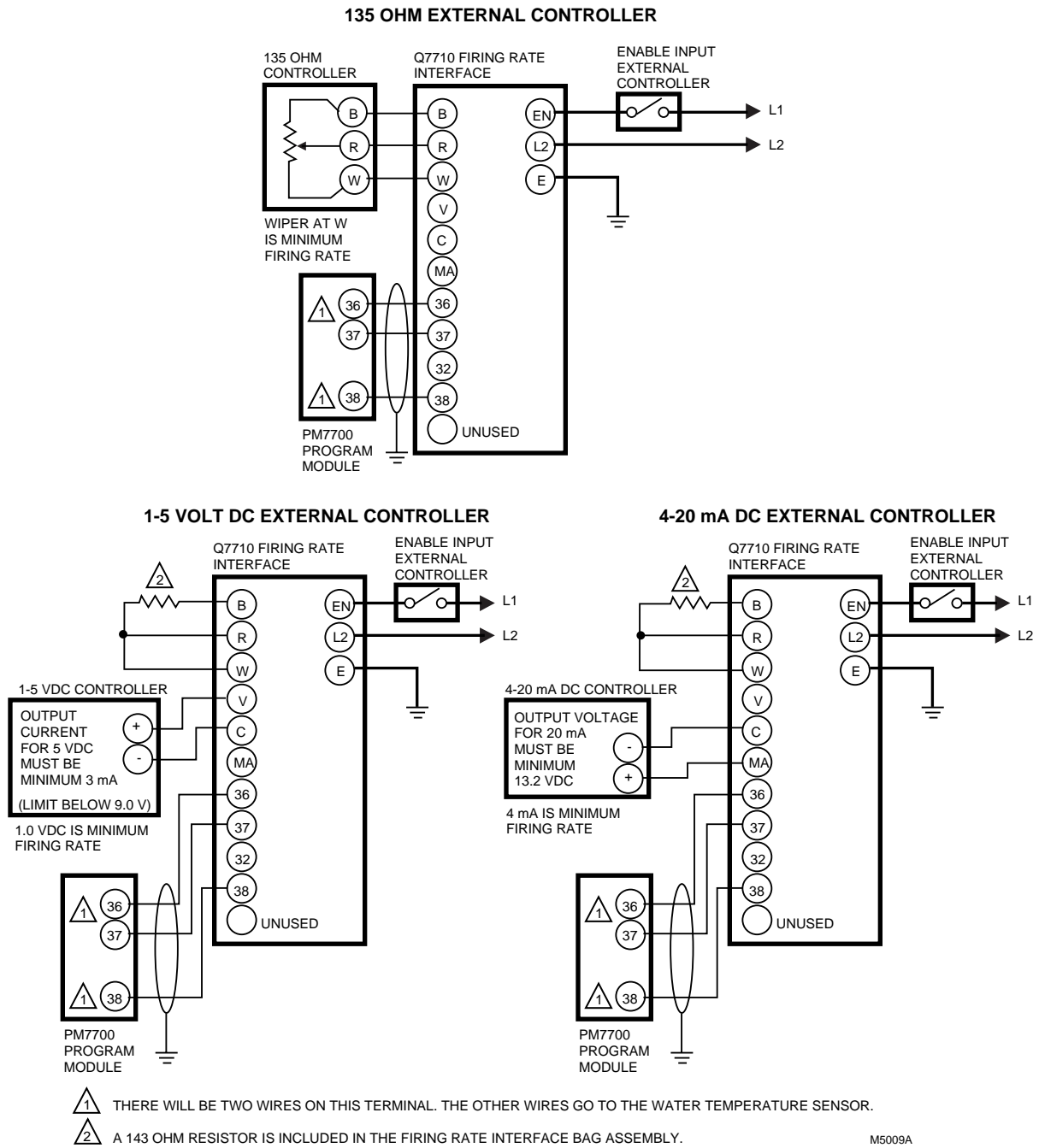

Fig. 4—Hot water wiring diagram.



Operation

The Firing Rate Interface is designed to interface the BCS 7700 with a 135 ohm, 4-20 mA, or 1-5 Vdc controller to start, stop, and adjust burner firing rate. To review the operation of the Firing Rate Interface, it is necessary to understand the functions of the BCS 7700 firing rate control modes.

The BCS 7700 provides three modes of firing rate operation; automatic (AUTO), manual (MAN), and remote (REM). When the BCS 7700 is configured for the Firing Rate Interface, see form 63-2291, the control mode shifts to the REM state. When configured for a Firing Rate Interface, the BCS 7700 ignores its internal burner sequencing on, off, and modulation settings as the on, off, and modulation control points are defined by the external controller connected to the Firing Rate Interface.

The Firing Rate Interface sequences the burner as follows (see Fig. 5):

1. The burner sequence starts when the Firing Rate Interface is enabled by powering the EN-L2 120 Vac input as defined by the external controller. When enabled, the Q7710 provides a voltage signal to the BCS 7700, which initiates a burner sequence.
2. The BCS 7700 sequences the burner through Pre-purge, Pilot Trial for Ignition, and Main Trial for Ignition.

3. When the Run period of the burner sequence is reached, the BCS 7700 relinquishes control of the firing rate motor (M741B) position to the Firing Rate Interface. The variable signal from the external control results in proportional positioning of the motor based on spanning the variable voltage across 0-90° motor position, see Fig. 6. This ability to position the firing rate motor adds capabilities such as Lead-Lag, Indoor/Outdoor Reset, and 4-20 mA control.

4. When the Firing Rate Interface is disabled, EN-L2 de-energizes, and the burner sequence advances to Postpurge under the BCS 7700 control.



CAUTION

When the BCS 7700 is in its remote (REM) mode, its internal BoilerOn and BoilerOff set points are not operational. The boiler will cycle off its high limit controls if an auxiliary operating limit control is NOT connected in series with the BCS 7700 Burner Switch or the Firing Rate Interface Enable Input.

Fig. 5—Firing Rate Interface sequence.

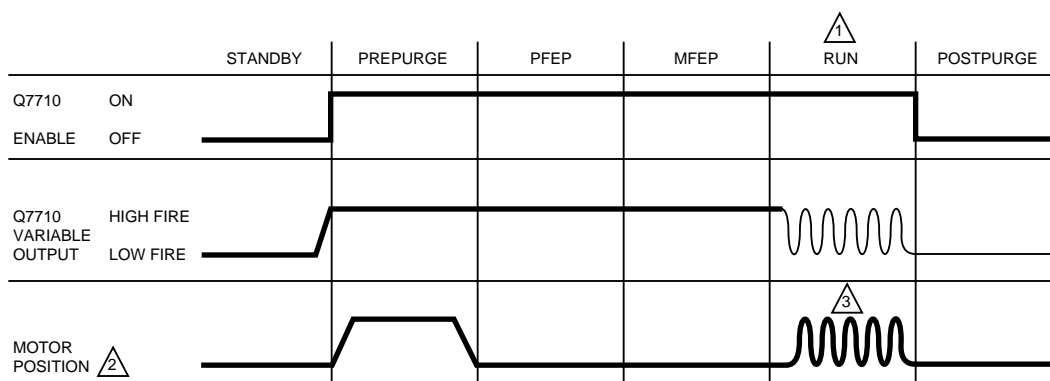

⚠ BURNER SEQUENCE TIMING CONTROLLED BY BCS 7700 SAFETY LOGIC.

⚠ MOTOR POSITION CONTROLLED BY BCS 7700 DURING STANDBY, PREPURGE, PFEP, MFEP AND POSTPURGE.

⚠ MOTOR POSITION CONTROLLED BY VARIABLE INPUT TO THE Q7710 DURING RUN.

M5010

Fig. 6—Motor position.

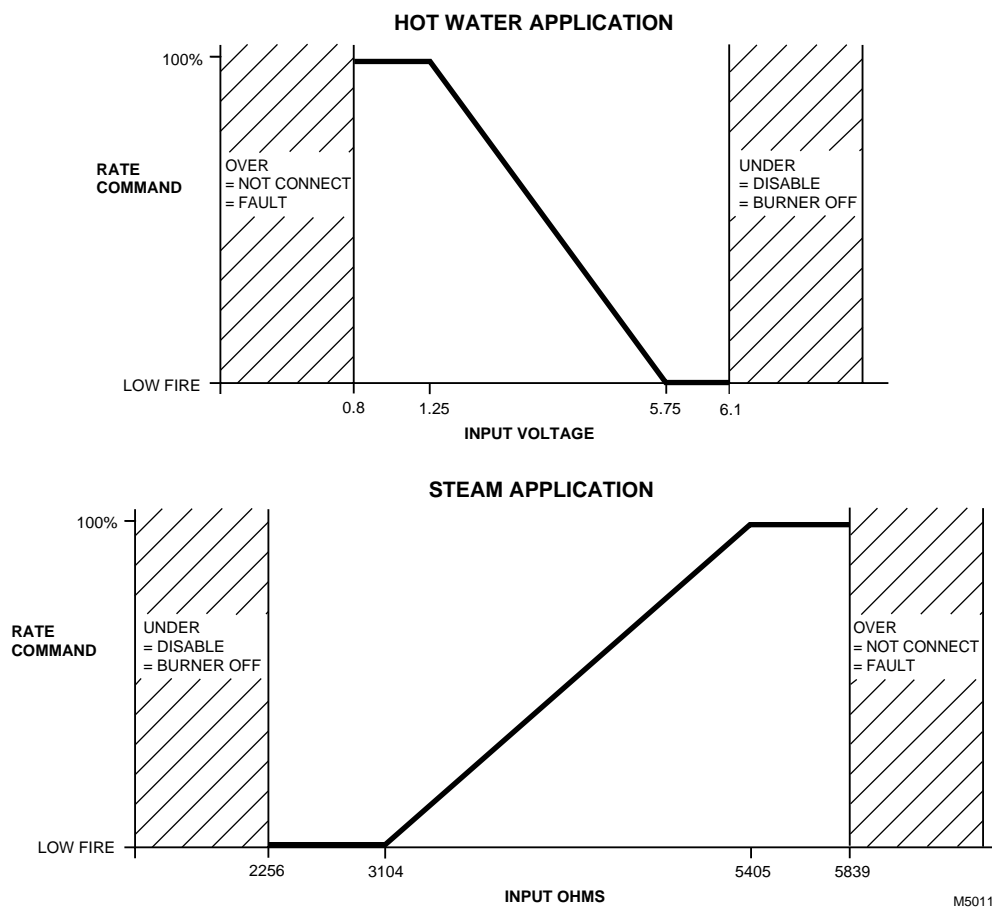

Checkout

The Firing Rate Interface operation can be reviewed by checking its ability to convert the controller inputs into the correct corresponding voltage outputs. The following sequence can be used to checkout the Firing Rate Interface.

1. Open the BCS 7700 Burner Switch input to assure the system will not sequence during checkout.

2. Locate the Diagnostic Information File by using the BCS 7700 Keyboard and Display Module.

3. With Firing Rate Interface Enabled (both POWER and ENABLE LEDs lit), read the steam pressure voltage (hot water boiler) or water temperature voltage (steam boilers) because the Firing Rate Interface is varied through its range (resistance, 1-5 Vdc or 4-20 mA). The values should remain within the following ranges:

4. When ENABLE LED is not lit, the following values should be read in the Diagnostic Information File regardless of input value:

Input Value	Diagnostic Value	
	Pressure	Temperature
R-B-W wiper at W, or 4 mA, or 1 Vdc	5.41 - 6.08 volts	1.56 - 1.74 Vdc
R-B-W wiper at B, or 20 mA, or 5 Vdc	.85 - 1.63 volts	2.77 - 2.98 Vdc

PRESSURE VOLTAGE: Greater than 6.1 volts

TEMPERATURE VOLTAGE: Less than 1.2 volts

Honeywell

Helping You Control Your World

Home and Building Control

Honeywell Inc.
1985 Douglas Drive North
Golden Valley, MN 55422

Home and Building Control

Honeywell Limited—Honeywell Limitée
740 Ellesmere Road
Scarborough, Ontario
M1P 2V9

QUALITY IS KEY

Printed in U.S.A.